

# Air Pollution Training Institute

## COURSE 413: CONTROL OF PARTICULATE MATTER EMISSIONS



## STUDENT WORKBOOK

UNITED STATES ENVIRONMENTAL PROTECTION AGENCY

Office of Air and Radiation  
Office of Air Quality Planning and Standards  
Research Triangle Park, NC 27711

*Prepared and Presented by:*  
William J. Franek, PhD, P.E., DEE and Louis DeRose J.D., M.S., P.E.

January, 2023





# Course 413

## Control of Particulate Matter Emissions

January 9 -13, 2023

### AGENDA

#### LOCATION

CenSARA Internet  
“Virtual”

#### INSTRUCTOR

William J, Franek, Ph.D., P.E. DEE  
Louis DeRose: J.D., M.S., P.E.

DAY & TIME	SUBJECT	SPEAKER
------------	---------	---------

#### **Monday (Central Time)**

9:00	Welcome and Registration	W. Franek
9:15	Review of Basic Concepts	L. DeRose
10:45	BREAK	
11:00	Particulate Matter Formation and Regulation	L. DeRose
12:30	Particle Sizing	W. Franek
1:15	ADJOURN	

---

*HOMEWORK: Read Chapters 1-4, Student Manual; Review Problems*

---

#### **Tuesday**

9:00	Particle Sizing (cont.)	W. Franek
10:00	Particle Collection Mechanisms	L. DeRose
10:45	BREAK	
11:00	Particle Collection Mechanism (cont.)	L. DeRose
11:45	Settling Chambers	L. DeRose
12:15	Cyclones	W. Franek
1:15	ADJOURN	

---

*HOMEWORK: Read Chapters 5-7, Student Manual; Review Problems*

---

#### **Wednesday**

9:00	Cyclones (cont'd)	W. Franek
9:45	Fabric Filters	W. Franek
10:45	BREAK	
11:00	Fabric Filters (cont'd)	W. Franek
1:15	ADJOURN	

DAY & TIME	SUBJECT	SPEAKER
------------	---------	---------

**Thursday**

9:00	Fabric Filters (cont'd)	W. Franek
9:30	Electrostatic Precipitators	L. DeRose
10:45	BREAK	
11:00	Electrostatic Precipitators	L. DeRose
12:15	Wet Scrubbers	W. Franek
1:15	ADJOURN	

---

*HOMEWORK: Read Chapters 8-10, Student Manual; Review Problems*

---

**Friday**

9:00	Wet Scrubbers (cont.)	W. Franek
10:30	BREAK	
10:45	Hoods and Fans	W. Franek
1:15	ADJOURN	

---

William J. Franek, Ph.D., P.E., DEE  
 William J. Franek, LLC  
 6807 West 64<sup>th</sup> Place  
 Chicago, IL 60638  
 Tel: 312-919-0341  
 E-mail: [billfranek@gmail.com](mailto:billfranek@gmail.com)

---

Louis DeRose: J.D., M.S., P.E.  
 Attorney at Law  
 221 Orchard Lane  
 Glen Ellyn, IL 60137  
 E-mail: [louderose@yahoo.com](mailto:louderose@yahoo.com)

## Chapter 1



# Basic Concepts

1

## Topics Covered

- Gas temperature
- Gas pressure
- Molecular weight and the mole
- Equation of state
- Viscosity
- Reynolds Number

2

## Gas Temperature

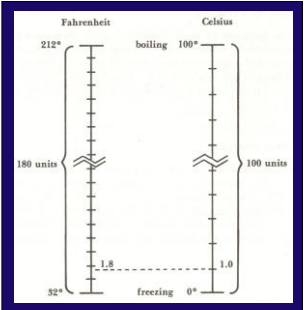

3

## Conversion Equations

$$^{\circ}\text{F} = 1.8^{\circ}\text{C} + 32$$

$$^{\circ}\text{C} = \frac{^{\circ}\text{F} - 32}{1.8}$$

4

## Absolute Temperature

- Kelvin
 
$$\text{K} = ^{\circ}\text{C} + 273$$
- Rankine
 
$$^{\circ}\text{R} = ^{\circ}\text{F} + 460$$

$$^{\circ}\text{R} = \text{K} \times 1.8$$

5

## Standard Temperature

Group	$T_{\text{std}}$
USEPA (General)	68°F (20°C)
USEPA (Air monitoring)	77°F (25°C)
Industrial hygiene	70°F (21.1°C)
Combustion	60°F (15.6°C)
Science	32°F (0°C)

6

### Example 1-1

The gas temperature in the stack of a wet scrubber system is 130°F. What is the absolute temperature in Rankine and Kelvin?

$$\text{Absolute Temp. } ^\circ\text{R} = 460^\circ\text{R} + 130^\circ\text{F} = 590^\circ\text{R}$$

$$\text{Absolute Temp. K} = \frac{590^\circ\text{R}}{1.8} = 327.8\text{K}$$

7

### Gas Pressure

- **Barometric pressure** (barometric pressure and atmospheric pressure are synonymous)
- **Gauge pressure** (same as static pressure)
- **Absolute pressure**

8

### Gauge Pressure

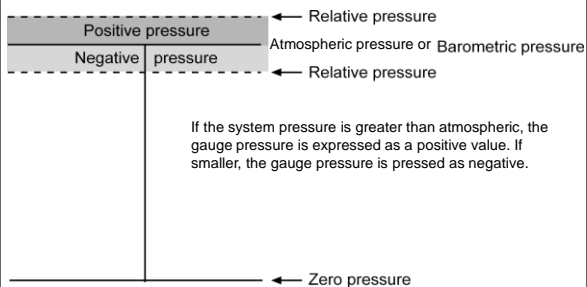

The pressure inside an air pollution control system is termed the *gauge or static pressure* and is measured relative to the prevailing atmospheric pressure.

9

### Flowchart of Labeled Temperatures and Pressures on a Hazardous Waste Incinerator

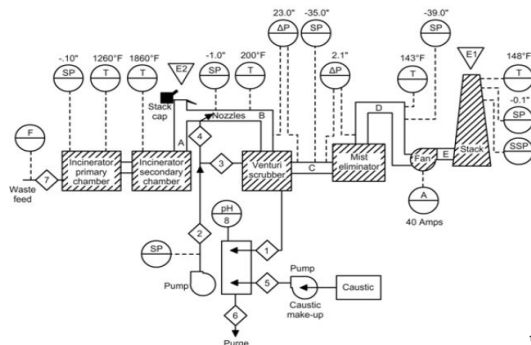

10

### Absolute Pressure

$$P = P_b + P_g$$

where

- P = absolute pressure
- P<sub>b</sub> = barometric pressure or atmospheric pressure
- P<sub>g</sub> = gauge (or static) pressure

11

### Standard Pressure

Units	Value
Atmosphere (atm)	1
Pounds force per square inch (psi)	14.70
Inches of mercury (in Hg)	29.92
Millimeters of mercury (mm Hg)	760
Feet of water column (ft WC)	33.92
Inches of water column (in WC)	407
Kilopascals (kPa)	101.3
Millibars (mb)	1013

**Standard barometric pressure** is the average atmospheric pressure at sea level, 45°N latitude, and at 35°F.

12

### Example 1-2

An air pollution control device has an inlet static pressure of -25 in WC.

What is the absolute static pressure at the inlet of the air pollution control device if the barometric pressure at the time is 29.85 in Hg?

$$P = P_b + P_g$$

Convert the barometric pressure units to inWC :

$$P_b = 29.85 \text{ in Hg} \left( \frac{407 \text{ in WC}}{29.92 \text{ in Hg}} \right) = 406 \text{ in WC}$$

Add the barometric and gauge (static) pressures :

$$P = 406 \text{ in WC} + (-25 \text{ in WC}) = 381 \text{ in WC}$$

## Molecular Weight

Molecular weight is the sum of the *atomic weights* of all atoms in a molecule

Mixtures of molecules do not have a true molecular weight; however, they do have an apparent molecular weight that can be calculated from the composition of the mixture:

$$MW_{\text{mixture}} = \sum_{i=1}^n \chi_i MW_i$$

$\chi_i$  = mole fraction of component i

$MW_i$  = molecular weight of component i

14

### Example

Calculate the average molecular weight of air at EPA standard conditions. Consider air to be composed of 21 mole% oxygen and 79 mole% nitrogen.

$$MW_{\text{mixture}} = \sum_{i=1}^n \chi_i MW_i$$

$$MW_{\text{air}} = 0.21 \left( 32 \frac{\text{g}}{\text{mole}} \right) + 0.79 \left( 28 \frac{\text{g}}{\text{mole}} \right) = 29 \frac{\text{g}}{\text{mole}}$$

$$MW = 29 \text{ g/mole}$$

15

## The Mole

A mole is a mass of material that contains a certain number of molecules. It is numerically equal to the molecular weight.



*The mass of one mole of a substance is equal to that substance's molecular weight.* For example, oxygen ( $O_2$ ) has an atomic weight of 16 with 2 atoms of oxygen ( $O_2$ ) in the molecule. Therefore, the molecular weight of  $O_2$  is  $(16 \times 2) = 32$ , and as a result there are 32 grams per gram-mole, 32 kilograms per kilogram-mole, and 32 pounds per-pound mole (of oxygen).

16

## Equation of State

The ideal gas law:

$$PV = nRT$$

P = absolute pressure  
V = gas volume  
n = number of moles  
R = constant  
T = absolute temperature

*Values for R:*

10.73 psia-ft<sup>3</sup>/lb-mole-°R  
0.73 atm-ft<sup>3</sup>/lb-mole-°R  
82.06 atm-cm<sup>3</sup>/g-mole-K  
8.31 x 10<sup>3</sup> kPa-m<sup>3</sup>/kg-mole-K

17

## Volume Correction

$$\frac{PV}{T} = nR = \text{CONSTANT (if } n = \text{CONSTANT)}$$

$$\frac{P_1 V_1}{T_1} = \frac{P_2 V_2}{T_2} \quad V_1 = V_2 \left( \frac{P_2}{P_1} \right) \left( \frac{T_1}{T_2} \right)$$

$$\text{SCFM} = \text{ACFM} \left( \frac{P_{\text{act}}}{P_{\text{std}}} \right) \left( \frac{T_{\text{std}}}{T_{\text{act}}} \right)$$

$$\text{ACFM} = \text{SCFM} \left( \frac{P_{\text{std}}}{P_{\text{act}}} \right) \left( \frac{T_{\text{act}}}{T_{\text{std}}} \right)$$

18

### Example 1-3

A particulate control system consists of a hood, ductwork, fabric filter, fan, and stack. The total gas flow entering the fabric filter is 8,640 scfm. The gas temperature in the inlet duct is 320°F and the static pressure is -10 in WC. The barometric pressure is 28.30 in Hg.

If the inlet duct has inside dimensions of 3 feet by 4 feet, what is the velocity into the fabric filter?

$$V = Q_{acfm} / \text{area}$$

$$ACFM = SCFM \left( \frac{P_{std}}{P_{actual}} \right) \left( \frac{T_{actual}}{T_{std}} \right)$$

Convert the static pressure to absolute pressure:

$$P = 28.30 \text{ in Hg} \left( \frac{407 \text{ in WC}}{29.92 \text{ in Hg}} \right) + (-10 \text{ in WC}) = 375 \text{ in WC}$$

$$P = P_b + P_g$$

19

### And then...

Convert the gas temperature to absolute temperature:

$$T_{actual} = 320^\circ\text{F} + 460 = 780^\circ\text{R}$$

Convert the inlet flow rate to actual conditions:

$$Q_{actual} = 8,640 \text{ scfm} \left( \frac{780^\circ\text{R}}{528^\circ\text{R}} \right) \left( \frac{407 \text{ in WC}}{375 \text{ in WC}} \right) = 13,853 \text{ acfm}$$

Calculate the velocity:

$$V = \frac{13,853 \text{ ft}^3/\text{min}}{3 \text{ ft} \cdot 4 \text{ ft}} = 1,154 \text{ ft}/\text{min}$$

20

### Molar Volume

$$\frac{V}{n} = \frac{RT}{P}$$

The ideal gas law may be rearranged to calculate the volume occupied by a mole of gas, called the *molar volume*

At 68°F and 1 atm. (EPA Standard conditions):

$$= \frac{\left( 0.73 \frac{\text{atm} \cdot \text{ft}^3}{\text{lb} \cdot \text{mole} \cdot ^\circ\text{R}} \right) (528^\circ\text{R})}{1 \text{ atm}} = 385.4 \frac{\text{ft}^3}{\text{lb} \cdot \text{mole}}$$

21

### Example 1-4

What is the molar volume of an ideal gas at 200°F and 1 atm?

At 200°F and 1 atm:

$$\frac{V}{n} = \frac{RT}{P} = \frac{\left( 0.73 \frac{\text{atm} \cdot \text{ft}^3}{\text{lb} \cdot \text{mole} \cdot ^\circ\text{R}} \right) (660^\circ\text{R})}{1 \text{ atm}} = 481.8 \frac{\text{ft}^3}{\text{lb} \cdot \text{mole}}$$

or  $\left( \frac{V}{n} \right)_{actual} \div \left( \frac{V}{n} \right)_{standard} = \left( \frac{RT}{P} \right)_{act} \div \left( \frac{RT}{P} \right)_{std}$

$$\frac{V}{n} = 385.4 \left( \frac{660^\circ\text{R}}{528^\circ\text{R}} \right) = 481.8 \frac{\text{ft}^3}{\text{lb} \cdot \text{mole}}$$

22

### Gas Density

$$PV = \left( \frac{m}{MW} \right) RT$$

$$\rho = \frac{m}{V} = \frac{P \cdot MW}{RT}$$

23

### Viscosity ( $\mu$ )

Viscosity is the proportionality constant associated with a fluid resistance to flow.

Figure 1-3

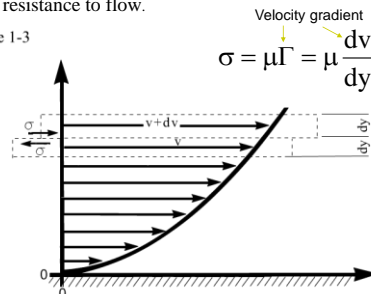

Shearing stress ( $\sigma$ ) between adjacent strata of a moving fluid

24



**Viscosity is the result of these two phenomena**

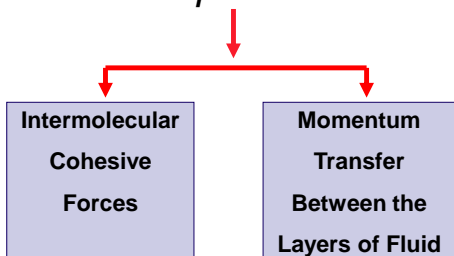

25

Predominantly the result of *intermolecular cohesion*. (forces of cohesion decrease rapidly with an increase in temperature)

**Heated Liquid = Lower Viscosity**



Predominantly the result of *momentum transfer between layers* of fluid. (molecular motion increases as temperature increases)

**Heated gas = Higher Viscosity**

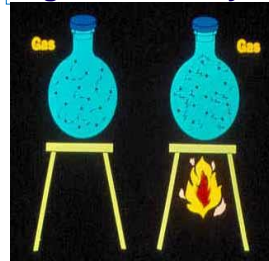

**Estimating Gas Viscosity of Air at Any Temperature:**

$$\frac{\mu}{\mu_{ref}} = \left( \frac{T}{T_{ref}} \right)^{0.768}$$

$\mu$  = absolute viscosity  
 $\mu_{ref}$  = absolute viscosity at reference temperature  
 $T$  = absolute temperature  
 $T_{ref}$  = reference absolute temperature

Viscosity of air at 68°F is  $1.21 \times 10^{-5}$  lb<sub>m</sub>/ft-sec 27

**Kinematic Viscosity**

The ratio of the absolute viscosity to the density of a fluid appears in dimensionless numbers.

$$\nu = \frac{\mu}{\rho}$$

where  
 $\nu$  = kinematic viscosity  
 $\mu$  = absolute viscosity  
 $\rho$  = density

28

**Reynolds Number**

$$Re = \frac{Lv\rho}{\mu}$$

where  
 $Re$  = Reynolds Number  
 $L$  = characteristic system dimension  
 $v$  = fluid velocity  
 $\rho$  = fluid density  
 $\mu$  = fluid viscosity

29

**Flow Reynolds Number**

$$Re = \frac{Dv\rho}{\mu}$$

Where for a circular duct  
 $D$  = duct diameter

30

### Particle Reynolds Number

$$Re_p = \frac{d_p v_p \rho}{\mu}$$

Where

$d_p$  = particle diameter

$v_p$  = relative particle to gas velocity

Most particle motion in air pollution control devices occurs in the Stokes and Transitional Regions

31

### Flow Regime

Three flow regimes:

$Re_p < 1$  laminar or Stokes flow

$1 < Re_p < 1000$  transition flow

$Re_p > 1000$  turbulent flow



### Example 1-5

Calculate the Particle Reynolds Number for a 2 $\mu$ m diameter particle moving through 10°C still air at a velocity of 6 m/sec.

$$Re_p = \frac{d_p v_p \rho}{\mu}$$

at constant pressure:

$$\rho_{act} = \rho_{std} \frac{T_{std}}{T_{act}}$$

$$\frac{\mu}{\mu_{ref}} = \left( \frac{T}{T_{ref}} \right)^{0.768}$$

33

### Solution...

From Appendix B, the density of air at 20°C is  $1.20 \times 10^{-3}$  g/cm<sup>3</sup> and the viscosity is  $1.80 \times 10^{-4}$  g/cm(sec)

Estimate the gas density at 10°C:

$$\rho = 1.20 \times 10^{-3} \left( \frac{293 \text{ K}}{283 \text{ K}} \right) = 1.24 \times 10^{-3} \frac{\text{g}}{\text{cm}^3}$$

Estimate the gas viscosity at 10°C:

$$\mu = 1.80 \times 10^{-4} \left( \frac{283 \text{ K}}{293 \text{ K}} \right)^{0.768} = 1.75 \times 10^{-4} \frac{\text{g}}{\text{cm} \cdot \text{sec}}$$

Calculate Particle Reynolds Number:

$$Re_p = \frac{d_p v_p \rho}{\mu} = \frac{(2 \times 10^{-4} \text{ cm})(6 \times 10^2 \text{ cm/sec})(1.24 \times 10^{-3} \text{ g/cm}^3)}{1.75 \times 10^{-4} \text{ g/cm} \cdot \text{sec}}$$

$$Re_p = 0.85$$

34

### Example 1-6

Calculate the Particle and Flow Reynolds Number for a gas stream moving through a 200 cm diameter duct at a velocity of 1,500 cm/sec.

- Assume that the particles are moving at the same velocity as the gas stream and are not settling due to gravity.

- Assume a gas temperature of 20°C and standard pressure.

Since there is no difference in velocity between the gas stream and the particle, the Particle Reynolds Number is zero.

35

### The Flow Reynolds Number is:

$$Re = \frac{Dv\rho}{\mu}$$

$$\frac{(200 \text{ cm})(1,500 \text{ cm/sec})(1.20 \times 10^{-3} \text{ g/cm}^3)}{1.80 \times 10^{-4} \text{ g/cm} \cdot \text{sec}} = 2.00 \times 10^6$$

36

**Review Problems**

1. The flows from Ducts A and B are combined into a single Duct C. The flow rate in Duct A is 5,000 scfm, the gas stream temperature is 350°F and the static pressure is -32 in WC. The flow rate in Duct B is 4,000 acfm, the gas stream temperature is 400°F and the static pressure is -35 in WC.

What is the flow rate in Duct C? Assume a barometric pressure of 29.15 in Hg. (see page 6)

37

**Solution #1**

$$Q_C \text{ scfm} = Q_A \text{ scfm} + Q_B \text{ scfm}$$

Calculate the absolute pressure in Duct B :

$$P = 29.15 \text{ in Hg} \left( \frac{407 \text{ in WC}}{29.92 \text{ in Hg}} \right) + (-35 \text{ in WC}) = 361.5 \text{ in WC}$$

Convert the flow in Duct B to standard conditions :

$$Q_B = 4,000 \text{ acfm} \left( \frac{528^\circ \text{R}}{860^\circ \text{R}} \right) \left( \frac{361.5 \text{ in WC}}{407 \text{ in WC}} \right) = 2,181 \text{ scfm}$$

Combine flows :

$$Q_C = 5,000 \text{ scfm} + 2,181 \text{ scfm} = 7,181 \text{ scfm}$$

38

**Review Problems**

2. Calculate the Particle Reynolds Numbers for the following particles. Assume a gas temperature of 20°C and a pressure of 1 atm. (see page 10)

- 10 μm particle moving at 1 ft/sec relative to the gas stream
- 10 μm particle moving at 10 ft/sec relative to the gas stream
- 100 μm particle moving at 1 ft/sec relative to the gas stream
- 100 μm particle moving at 10 ft/sec relative to the gas stream

From Appendix B, the density of air at 20°C is 1.20 x 10<sup>-3</sup> g/cm<sup>3</sup> and the viscosity is 1.80 x 10<sup>-4</sup> g/cm(sec)

39

From Appendix B, the density of air at 20°C is 1.20 x 10<sup>-3</sup> g/cm<sup>3</sup> and the viscosity is 1.80 x 10<sup>-4</sup> g/cm(sec)

**Solution #2 (a & b)**

a. 10 μm particle moving at 1 ft/sec relative to the gas stream

$$Re_p = \frac{d_p v_p \rho}{\mu} = \frac{(10 \times 10^{-4} \text{ cm}) \left[ (1.0 \text{ ft/sec}) \left( \frac{30.48 \text{ cm}}{\text{ft}} \right) \right] (1.20 \times 10^{-3} \text{ g/cm}^3)}{1.80 \times 10^{-4} \text{ g/cm} \cdot \text{sec}} = 0.203$$

b. 10 μm particle moving at 10 ft/sec relative to the gas stream

$$Re_p = \frac{d_p v_p \rho}{\mu} = \frac{(10 \times 10^{-4} \text{ cm}) \left[ (10.0 \text{ ft/sec}) \left( \frac{30.48 \text{ cm}}{\text{ft}} \right) \right] (1.20 \times 10^{-3} \text{ g/cm}^3)}{1.80 \times 10^{-4} \text{ g/cm} \cdot \text{sec}} = 2.032$$

40

**Solution #2 (c & d)**

c. 100 μm particle moving at 1 ft/sec relative to the gas stream

$$Re_p = \frac{d_p v_p \rho}{\mu} = \frac{(100 \times 10^{-4} \text{ cm}) \left[ (1.0 \text{ ft/sec}) \left( \frac{30.48 \text{ cm}}{\text{ft}} \right) \right] (1.20 \times 10^{-3} \text{ g/cm}^3)}{1.80 \times 10^{-4} \text{ g/cm} \cdot \text{sec}} = 2.03$$

d. 100 μm particle moving at 10 ft/sec relative to the gas stream

$$Re_p = \frac{d_p v_p \rho}{\mu} = \frac{(100 \times 10^{-4} \text{ cm}) \left[ (10.0 \text{ ft/sec}) \left( \frac{30.48 \text{ cm}}{\text{ft}} \right) \right] (1.20 \times 10^{-3} \text{ g/cm}^3)}{1.80 \times 10^{-4} \text{ g/cm} \cdot \text{sec}} = 20.3$$

41



## Particulate Matter: Effects, Sources, Formation, and Regulation

---



**Chapter 2**

1

### How Pollutants Enter the Body

- Contact with skin or eyes
- Ingestion
- Inhalation
  - most common for air pollutants

2

### Human Respiratory System

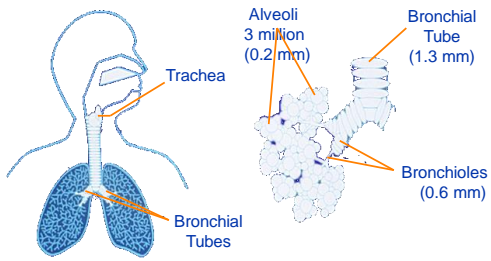

3

### Particulate Deposition in Respiratory System

- Large particles:
  - Impaction (nasal hairs & bends of passages)
- Smaller particles (1 to 10 microns):
  - Windpipe (can't follow streamline)
- Smallest particles (< 1 micron):
  - Alveoli
  - Can take weeks or months to remove

4

### Air Quality: Pollutants—Particles

- Smaller particles have more serious health impacts.

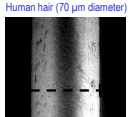
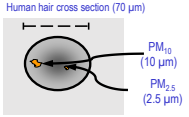
<p><b>Coarse Particles (PM<sub>10</sub>)</b></p> <ul style="list-style-type: none"> <li>■ Size: &lt; 10 μm</li> <li>■ Smaller than a human hair</li> </ul>  <p style="font-size: small;">Human hair (70 μm diameter)</p>	<p><b>Fine Particles (PM<sub>2.5</sub>)</b></p> <ul style="list-style-type: none"> <li>■ Size: &lt; 2.5 μm</li> <li>■ Greater health concern</li> </ul>  <p style="font-size: small;">Human hair cross section (70 μm)</p> <p style="font-size: x-small;">M. Lopez, California Office of Environmental Health Hazard Assessment</p>
---	--

5

### Respiratory System Defense Mechanism

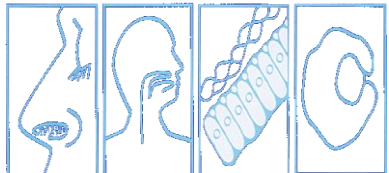

Nasal Hair  
(impaction)

Mucus  
Membrane  
(absorption)

Cilia  
(mucociliary  
escalator)

Immune  
Responses  
(alveoli  
macrophages)

6

### Effects on Respiratory System

- Bronchitis (inflammation of airways)
- Pulmonary emphysema (lungs lose elasticity)
- Pneumoconiosis (chronic inflammation of lungs)
- Lung cancer

7

### Health Effects of Particulate Matter

- Increased respiratory illness
- Aggravation of respiratory conditions, i.e. asthma
- Decreased lung function
- Chronic bronchitis
- Premature death in people with heart/lung disease

An extensive body of scientific evidence shows that short- or long-term exposures to fine particles can cause adverse cardiovascular effects, including heart attacks and strokes resulting in hospitalizations and, in some cases, premature death.

8

### Environmental Effects of Particulate Matter

- visibility impairment,
- effects on materials (e.g., building surfaces),
- climate impacts, and
- ecological effects

9

### Sources of PM<sub>2.5</sub> & PM<sub>10</sub>

- Fossil-fuel combustion
- Transportation
- Industrial processes
- Agriculture & Forestry
- Fugitive dust

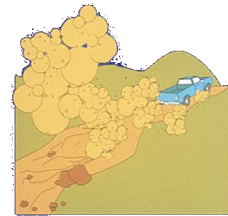

Unlike other criteria pollutants, PM is not a single specific chemical entity, but rather a *mixture of particles from different sources with different chemical compositions.*

10

### U.S. Direct PM<sub>10</sub> Emissions by Anthropogenic & Other Sources in 2014

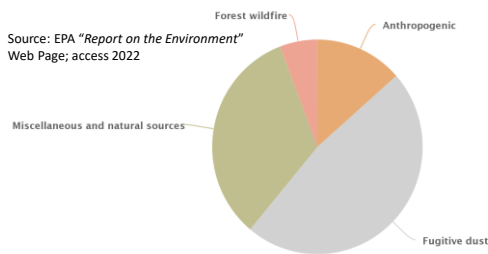

11

### Anthropogenic Direct PM<sub>10</sub> Emissions by Source Category in the U.S. (1990 to 2014)

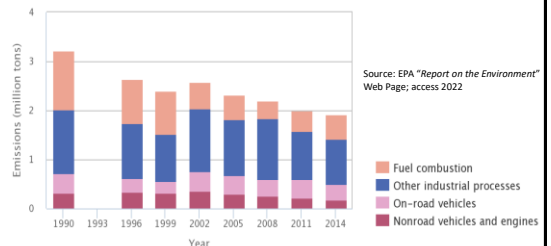

During some parts of the period of record, inventories were only developed every three years, hence the three-year intervals shown here. Data are available for inventory year 1993, but these data have not been updated to allow comparison with data from the other years shown.

12

### PM<sub>2.5</sub>: Composition and Sources

- **Directly** emitted particles:
  - Crustal
    - Sources: unpaved roads, agriculture & high wind events
    - Mostly larger than 2.5 microns
  - Carbonaceous
    - Sources: all types of combustion
- **Secondary particles** (chemical transformation of gaseous pollutants):
  - Ammonium sulfate and ammonium nitrate
  - Secondary organics (from VOCs)

13

### PM<sub>2.5</sub> In Ambient Air - A Complex Mixture

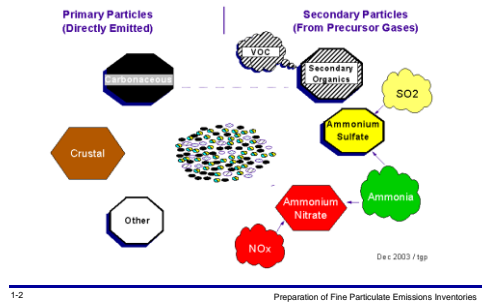

### PM<sub>2.5</sub> Emissions by Source Category, 2003

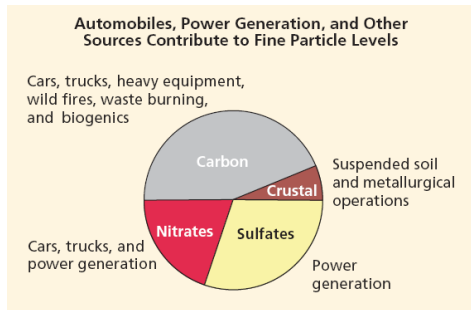

### Regional Differences in PM<sub>2.5</sub> Composition

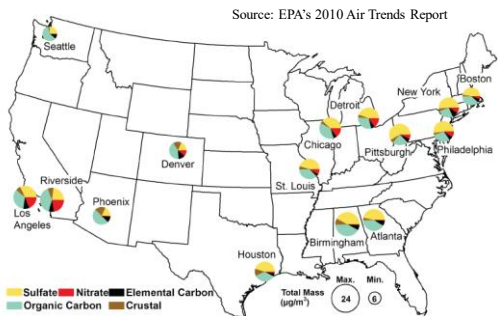

### U.S. PM<sub>2.5</sub> Emissions from Anthropogenic and Other Sources: 2014

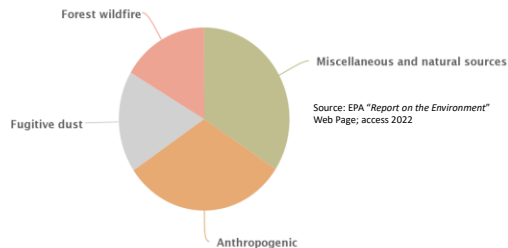

### Anthropogenic PM<sub>2.5</sub> Emissions in the U.S. by Source Category: 1990 to 2014

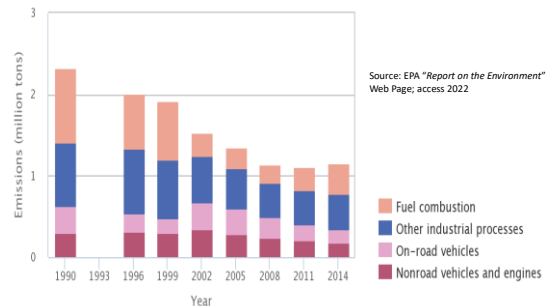

### Particle Formation Mechanisms

- **Physical attrition** occurs when two surfaces rub together & yields small particles that break off.
- **Combustion**: As oxidation progresses, the fuel particles, (100-1,000 mm), are reduced to ash and char particles that are primarily in the 1 to 10 mm range (i.e. boiler).
- **Droplet Evaporation**: When solids containing water is atomized during injection into the hot gas streams, these small droplets evaporate & the suspended solids are released as small particles.
- **Homogeneous nucleation** and **heterogeneous nucleation** involve the conversion of vapor phase materials to a particulate matter form.
  - **Homogeneous nucleation** is the formation of new particles composed almost entirely of the vapor phase material.
  - **Heterogeneous nucleation** is the accumulation of material on the surfaces of particles that have formed due to other mechanisms.

### Heterogeneous Nucleation

- A consequence of heterogeneous nucleation is that the metals (volatilized during high temperature operations) are deposited (nucleate) in small quantities on the surfaces of a large number of small particles.
- In this form, the metals are available to participate in catalytic reactions with gases or other vapor phase materials that are continuing to nucleate.

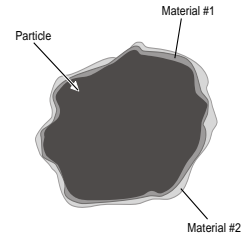

20

### Physical Attrition

**Grinding Wheel:** the grinding of a rod yields small particles that break off from both surfaces. The compositions & density of these particles are identical to the parent materials.

**Tertiary crusher:** very little of the particulate matter is less than 10 mm. Physical attrition generates primarily large particles.

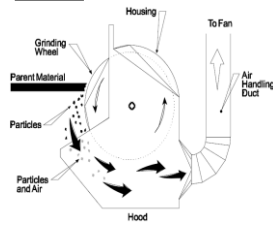

21

### Summary of Formation Mechanisms

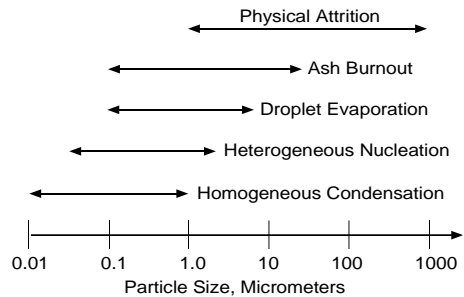

Homogeneous and heterogeneous nucleation generally creates particles that are very small, often between 0.05 and 1.0 mm.

22

## Particulate Matter Regulation



### State & Local Control Initiatives

- After 1850, the U.S. industrial revolution took hold; centering on steel, iron with abundant coal usage.
  - *“Smoke is the incense burning on the altars of industry. It is beautiful to me.”* by a Chicago businessman in 1892.
  - **Public Policy favored business:** economic growth over human health & property protection until FDR & his New Deal programs. (From 1860 to 1930: pro-business SCOTUS justices policies – “laissez-faire” – leave corporations alone.)
- In 1881, Chicago & Cincinnati passed municipal regulations of smoke emissions, and by 1912, most major U.S. cities followed.

452-1-24



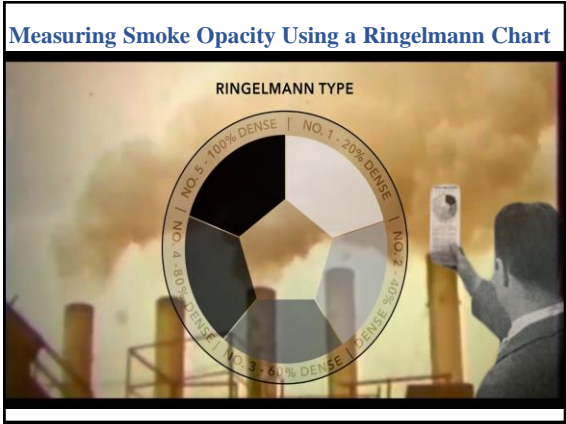

### Donora Episode: Oct. 26, 1948

- Start of a 5 day temperature inversion
- 50% of all residents sick (6,000 people)
  - Chest pains, cough & labored breathing
  - Irritation in eyes, nose and throat
- 20 people died
- Furnaces not shut down until the last day
  - Zinc furnaces like coke ovens were not allowed to stop, once cooled it cannot be restarted.
- Town doctor told everyone to leave town
  - Many went to a park high on a hill, as soon as they rose above smog, they started to feel better.

452-1-26

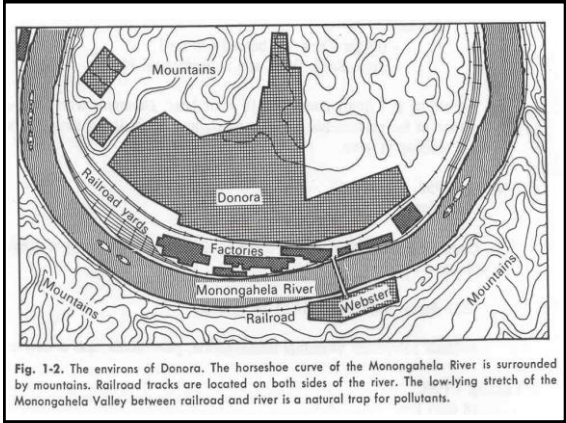

Fig. 1-2. The environs of Donora. The horseshoe curve of the Monongahela River is surrounded by mountains. Railroad tracks are located on both sides of the river. The low-lying stretch of the Monongahela Valley between railroad and river is a natural trap for pollutants.

### Donora: Investigations resulted, but none could produce direct evidence of air pollution's harm.

Surgeon General, Scheele, wrote in the report's foreword: "This study is the opening move ... in improving the nations health. We have realized during our growing impatience with the annoyance of smoke, that pollution from gases, fumes & microscopic particles was also a factor to be reckoned with."

Surgeon General, Scheele, wrote in the report's foreword: "This study is the opening move ... in improving the nations health. We have realized during our growing impatience with the annoyance of smoke, that pollution from gases, fumes & microscopic particles was also a factor to be reckoned with."

28

### Contaminant Regulations

- Prior to 1950 some *states and local agencies enacted particulate pollutant control regulations (opacity) & were not aware of gaseous contaminants effects* such as SO<sub>2</sub>, VOCs, and HF.
- The environmental awareness that began to increase during the 1950s and 1960s culminated in the enactment of the Clean Air Act of 1970.

29

### Federal Legislative Landmarks

- **1955 Air Poll. Control Act:** Fed research funding
- *Debates:* Fed or state responsibility
- **1963 CAA:** (compromise) Funding for state air programs
- **1965 CAAA:** Auto emission stds. (CO & HxCx)
- *Debates:* national stds. vs. regional stds.  
ambient air stds. vs. emission stds.
- **1967 Air Quality Act:** States set regional air quality stds. based on federal air quality criteria
  - States failed to set stds., collect ambient air data & conduct emission inventories (21 SIPs submitted; none approved)
  - HEW (understaffed) failed to set air quality control regions
- **1970 CAAA:** (sharply increased fed authority)
  - Uniform NAAQS, SIP, NSPS, NESHAP, & mobile sources

30

### Passage of the 1970 CAA

President Richard Nixon signs the CAA on Dec 31, 1970

Senator Edmund Muskie: Chairman of the Subcommittee on Water and Air Pollution



452-1-31

### Federal Legislative Landmarks

- **1977 CAA Amendments**
  - PSD
  - Non-attainment provisions
- **1990 CAA Amendments**
  - Revised HAP program
  - Acid Rain & Ozone depletion
  - Title V Operating Permits
  - Strengthened enforcement provisions
  - New classifications for non-attainment areas

32

### NAAQS

- 6 criteria pollutants:
  - NO<sub>2</sub>, CO, SO<sub>2</sub>, Ozone, Lead, PM10 & PM2.5
  - <https://www.epa.gov/criteria-air-pollutants/naaqs-table>
- **Primary** standard: (public health)
  - “adequate margin of safety” to protect people regardless of age, health etc.
- **Secondary** standard: (public welfare)
- EPA cannot consider “costs” of implementation in setting the standard.
- EPA to review NAAQS every 5 years

33

### National Ambient Air Quality Standards

Pollutant	Averaging Time	Primary	Secondary
PM-2.5 (2012)	Annual	12 µg/m <sup>3</sup>	None
PM-2.5 (2006)	Annual	None	15 µg/m <sup>3</sup>
PM-2.5 (2006)	24-hour	35 µg/m <sup>3</sup>	Same
PM-10 (1987)	24-hour	150 µg/m <sup>3</sup>	Same
SO <sub>2</sub> (2010)	1-hour	75 ppb	None
	3-hour	None	500 ppb
CO (1971)	8-hour	9 ppm	None
	1-hour	35 ppm	None
Ozone (2015)	8-hour/day	0.070 ppm	Same
NO <sub>2</sub> (2010)	1-hour/day	100 ppb	None
	Annual	53 ppb	Same
Lead (2008)	3mo. average	0.15 µg/m <sup>3</sup>	Same

34

### PM Standards Have Changed Over Time

- 1971: EPA set standards covering all sizes of airborne particles, known as a “total suspended particulate, **TSP**”
- 1987: EPA changed the standards to focus on particles 10 micrometers in diameter and smaller (**PM10**)
  - EPA set both 24-hour and annual PM10 standards at that time
- 1997: Added new fine particles indicator – **PM2.5** (set initial 24-hr standard & an annual standard)
  - Retained PM10 standards
- 2006: EPA maintained both PM standards:
  - *Fine particles: Revised level of 24-hour PM2.5 standard (65 to 35 µg/m<sup>3</sup>) and retained level of annual PM2.5 standard (15 µg/m<sup>3</sup>)*
  - *Coarse particles: retained 24-hour PM10 standard and revoked annual PM10 standard*

35

### New Particulate Standard (12/14/12)

- **Strengthened** the primary **annual** standard for fine particles (**PM2.5**) to **12 µg/m<sup>3</sup>** from 15 µg/m<sup>3</sup>.
- **Retained** the existing primary **24-hour** standard for fine particles (**PM2.5**) at **35 µg/m<sup>3</sup>**.
- **Retained** the existing primary **24-hour** standard for coarse particles (**PM10**) of **150 µg/m<sup>3</sup>**.
- **Retained** all the existing **secondary standards**
  - (2006) PM2.5 & (1987) PM10 secondary standards.
- **Attainment: 2020-2025** (depends on severity of problem).

36

### Summary of New 2012 NAAQS for PM<sub>10</sub> & PM<sub>2.5</sub>

Particle Pollution (PM)	PM <sub>2.5</sub>	primary	1 year	12.0 µg/m <sup>3</sup>	annual mean, averaged over 3 years
		secondary	1 year	15.0 µg/m <sup>3</sup>	annual mean, averaged over 3 years
	primary and secondary	24 hours	35 µg/m <sup>3</sup>	98th percentile, averaged over 3 years	
		PM <sub>10</sub>	24 hours	150 µg/m <sup>3</sup>	Not to be exceeded more than once per year on average over 3 years

- ### Air Quality Control Regions
- **Attainment**
    - Any area that meets the NAAQS
  - **Nonattainment**
    - Any area that does not meet primary and secondary NAAQS for that pollutant
  - **Unclassifiable**
    - Any area with insufficient air quality data to determine the status for that area

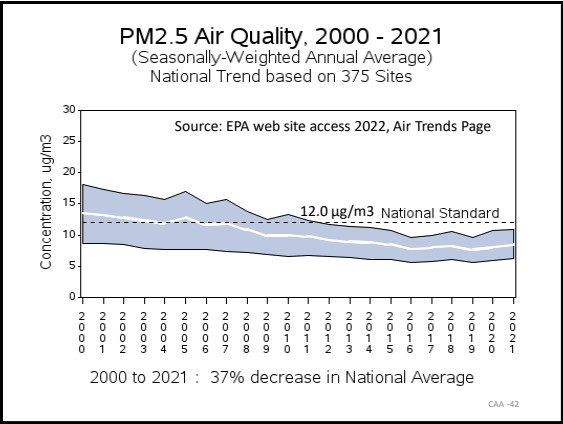
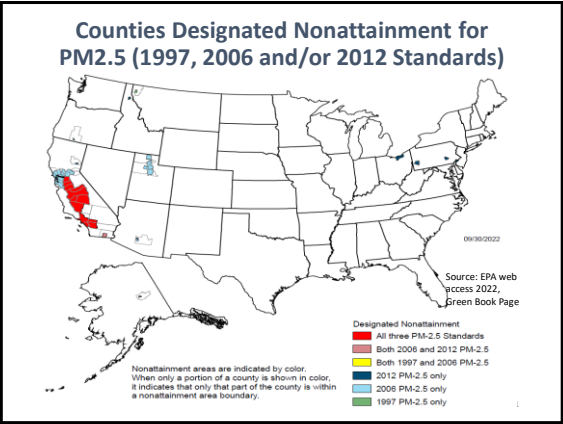
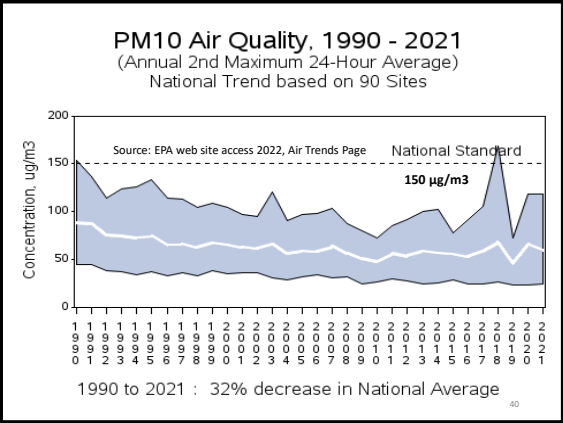
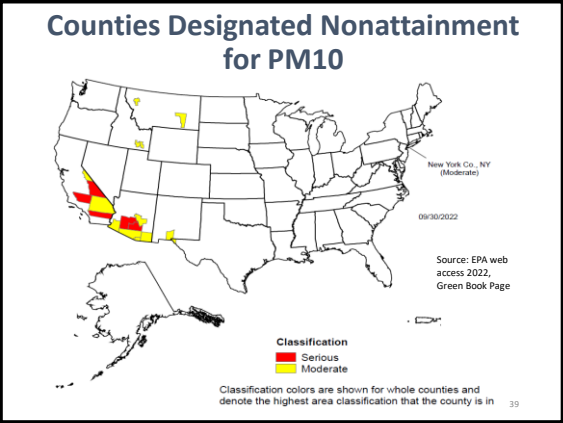

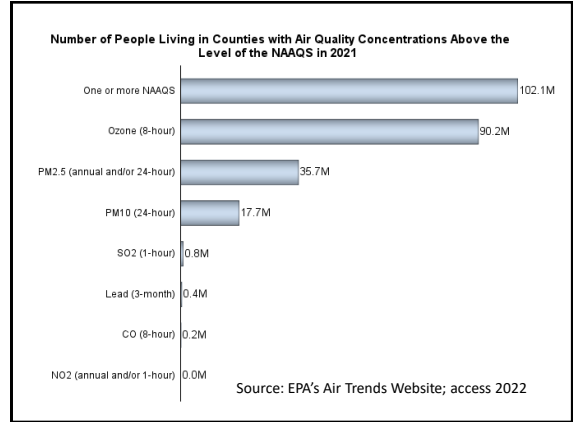
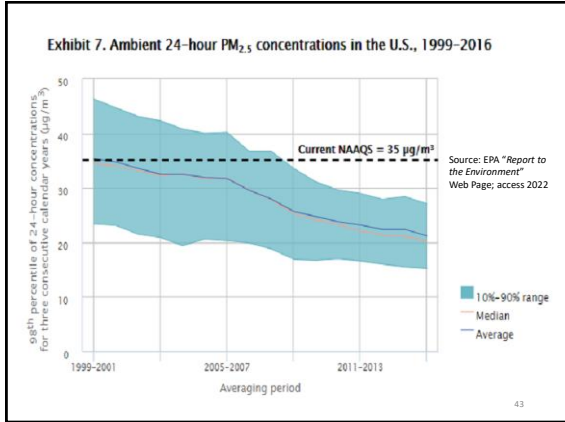

### State Implementation Plan (SIP)

- A *SIP* is the air pollution measures & strategies adopted by a state & approved by EPA for attaining and maintaining the NAAQS.
- Particulate matter regulations were adopted by the states and local agencies to implement the SIP control strategies.
- These particulate matter emission limitations took many regulatory forms, many of which are still in effect today.

### Types of PM Emission Regulations

- **PM emissions based on a fuel heat input:** For stationary combustion sources: This type of regulation limits the total particulate matter emissions based on a fuel heat input basis.
  - i.e. Allowable emission rate in pounds PM per million BTU of heat input
- A **process weight-based PM emission regulation** is used for industrial process sources. It is similar to the fuel burning regulation because the allowable emissions are a function of the process operating rate.
- **Plume Opacity**
- **Fugitive Emissions**

### NSPS for Fossil Fuel-fired EGUs

Table 1-7. New source performance standards for fossil fuel-fired electric power generating facilities

Category	Fuel Type	Emission Limit	Reduction Requirement
Particulate Matter	Solid	0.015 lb <sub>m</sub> /10 <sup>6</sup> Btu <sup>A</sup>	99.9%
SO <sub>2</sub>	Liquid	1.4 lb <sub>m</sub> /MWh	95%
SO <sub>2</sub>	Coal Refuse	1.4 lb <sub>m</sub> /MWh	94%
		<0.6 lb <sub>m</sub> /10 <sup>6</sup> Btu	70%
NO <sub>x</sub>	Solid	0.5 lb <sub>m</sub> /10 <sup>6</sup> Btu	65%
NO <sub>x</sub>	Liquid	0.3 lb <sub>m</sub> /10 <sup>6</sup> Btu	30%
NO <sub>x</sub>	Gas	0.2 lb <sub>m</sub> /10 <sup>6</sup> Btu	20%
NO <sub>x</sub>		1.0 lb <sub>m</sub> /MWh	
NO <sub>x</sub>	Liquid Backup Fuel <sup>B</sup>	1.5 lb <sub>m</sub> /MWh	

A: The owner/operator of a facility with a PM Continuous Emission Monitoring System (CEMS) may elect to comply with an alternate 0.14 lb<sub>m</sub>/MWh standard.

Note: NSPS under CAA 111(b) are emission limits only. But when emission limits are not "feasible" (i.e. fugitives) then under 111(h) then the NSPS can be based on design, equipment, work practice, or operational standard

### Minn. Process Weight-Based PM Emission Regulation

- **Example:** particulate matter emissions from equipment to which no specific state rule or federal regulation apply are limited under the general "Industrial Process Equipment Rule" (Minn. R. 7011.0700 - 7011.0735). The rule includes a maximum limit that is never to be exceeded.
- For  $P \leq 60,000$  lb/hr  $E = 3.59 \times (P \div 2000)^{0.62}$
- For  $P > 60,000$  lb/hr  $E = 17.31 \times (P \div 2000)^{0.16}$
- P = process weight rate, in lb/hr
  - "Process weight rate" as defined in the rules is the total weight in a given time period of all materials introduced into any industrial process equipment that may cause any emission of particulate matter.
- E = particulate emission rate, in lb/hr

### Types of PM Emission Regulations

**Plume Opacity:** is a measure of the extent to which the PM emissions reduce the ambient light passing through the plume. It can be determined by a trained observer.

**Fugitive Emissions:** Regulations include (1) required work practices, (2) visible emission (opacity) limits at plant boundary lines, and (3) visible emission limits at the process source.

49

### Overlap Between HAPs and Criteria Pollutants

- PMs is comprised of many chemicals, some which may be HAPs:
  - i.e., trace metals or hazardous organic matter
- Lead Compounds: (HAP) Lead: Criteria Pollutant

50

### Hazardous Air Pollutants: 1990 Amendments

- Congress lists 189 substances as HAP
  - EPA can add or delete
- EPA to list sources of HAP
  - 174 major and 8 area sources
- EPA to establish a control technology-based emission standards (MACT)
  - 25% in 2 yrs; 50% in 7 yrs; all in 10 yrs.
- Residual Risks program
  - 8 yrs. after MACT: EPA required to pass health-based emission standards if necessary (based on a EPA conducted risk assessment)

51

### Maximum Achievable Control Technology (MACT)

- Major source: any stationary source that has the potential to emit more than:
  - 10 tpy of a listed HAP, or
  - 25 tpy of a combination of listed HAP
- All HAP major sources must meet MACT
  - Technology-based & costs considered
  - New sources Use technology-based control standard based on best controlled similar sources
  - Existing sources Use technology-based control standard based on best controlled 12% of existing sources

52

### New Source Performance Standards (NSPS)

- Applies in Attainment & Non-attainment areas

Source Category	Subpart
Industrial-Commercial-Institutional Generating Units	Db
Small Industrial-Commercial-Institutional Steam Generating Unit	De
Large Municipal Waste Combustors	Eb
Hospital/Medical/Infectious Waste Incinerators	Ec
Portland Cement Plants	F
Hot Mix Asphalt Facilities	I
Petroleum Refineries	J
Secondary Brass and Bronze Production Plants	M
Secondary Emissions From Basic Oxygen Process Steelmaking	Na
Sewage Treatment Plants	O
Kraft Pulp Mills	BB
Glass Manufacturing Plants	CC

53

### New Source Review

- (PSD) Prevention of Significant Deterioration
  - Attainment areas or Unclassifiable areas only
  - “Major” = 250 tpy or 100 tpy (in 28 listed categories)
  - In a “major modification,” significant emission rate is PM2.5 = 10 tpy & PM10 = 15 tpy
  - Best Available Control Technology (BACT)
- Non-attainment New Source Review
  - Non-attainment areas only
  - “Major” = 100 tpy
    - Non-attainment classification can lower “Major” to 70tpy of PM10
  - Lowest Achievable Emission Rate (LAER)

54

### BACT & LAER Determination Example

- Control A: 60% efficient @ cost = \$50,000/yr.
- Control B: 90% efficient @ cost = \$60,000/yr.
- Control C: 94% efficient @ cost = \$90,000/yr.
- Control B would be BACT because it is the most *cost effective* for tons of pollutant removed.
- Control C: may be LAER because it is the "most stringent emission limitation ... achievable in practice" by similar sources.

55

### Title V

- 1990 CAAA created the Title V Operating Permit Program
- Purpose of Title V Permit is to *specify all the CAA "applicable requirements" under one permit.*
- All Major Sources stationary sources must obtain a Title V permit
  - This includes any **CAA air pollutant ≥ 100 tons/yr.** (except GHGs)
- Title V requires "periodic monitoring:" For example, for an uncontrolled glass furnace with a 20% opacity standard and a 0.04 gr/scf PM emission limit, *a state might determine that periodic monitoring is a weekly visible emission reading for the opacity standard and an annual stack test for the emission limit.*

56

### Transport Rules

- 2005: EPA passed **Clean Air Interstate Rule (CAIR)** to limit the interstate transport of emissions of  $NO_x$  and  $SO_2$  from power plants that contribute to fine particle matter (PM<sub>2.5</sub>) and ozone in downwind states.
  - $NO_x$  and  $SO_2$  contributes to fine PM formation &  $NO_x$  contributes to  $O_3$  formation.
- 2011 EPA replace CAIR with the **Cross State Air Pollution Rule (CSAPR)** to achieve emission reductions beyond those originally required by CAIR.
- Both transport rules required certain states to utilize cap & trade programs to limit annual  $NO_x$  and  $SO_2$  emissions by 2015.

57

### Cross State Air Pollution Rule States

CSAPR includes three separate cap and trade programs: the CSAPR  $SO_2$  annual trading program, the CSAPR  $NO_x$  annual trading program, and the CSAPR  $NO_x$  ozone season trading program.



- 17 states are covered by CSAPR Update for ozone (seasonal  $NO_x$ ) and by CSAPR for fine particles ( $SO_2$  and annual  $NO_x$ ).
- 5 states are covered by CSAPR Update for ozone (seasonal  $NO_x$ ) only.
- 4 states are covered by CSAPR for fine particles ( $SO_2$  and annual  $NO_x$ ) only.
- Georgia is covered by CSAPR for both fine particles ( $SO_2$  and annual  $NO_x$ ) and ozone (seasonal  $NO_x$ ).
- The ARP covers sources in the lower 48 states.

### Visibility Impairment



59

### The 1977 CAAA Addressed "Visibility Protection" for the First Time

- Added CAA  $\delta 169A$
- $\delta 169A$  sets national goal of eliminating manmade visibility impairments in Class I areas.
- EPA identified 156 Class I areas for visibility protection in 40 CFR Part 81, Subpart D



Map of 156 National Park and Wilderness Areas Protected by EPA's Regional Haze Rule

**1977 CAAA “Visibility Protection” CAA §169A**

- §169A required each state containing a Class I area & other states that cause a visibility impairment at a Class I area to **develop SIPs** which includes **BART** (best available retrofit technology) *for certain existing stationary sources contributing to the impairment.*
- States must make **BART determinations** from EPA guidelines.
  - 2005: States may consider options more stringent than the NSPS in any BART determination.
  - 2006: States can develop SO<sub>2</sub> & NO<sub>x</sub> emission trading program to replace BART guidelines.

61

**Sources Required to Install BART**

- §169A required certain “major stationary sources” to install BART, sources must be both “BART eligible” & “subject to BART.”
- **BART eligible:** The BART requirements apply to facilities (listed categories in §169A) built between 1962 and 1977 that have the PTE ≥ 250 tons per year of visibility-impairing pollution.
- **Subject to BART:** Next, states must determine if that source emits any air pollutant which may reasonably be anticipated to cause or contribute to visibility impairment. (“reasonably attribute”)
  - Use modeling to assess visibility: Impacts ≥ 1.0 deciview “cause” visibility impairment & ≥ 0.5 deciview to “contribute” to impairment. (“reasonably attribute” test).

62

**Visibility Protection: 1990 CAAA & 1999 Regional Haze Rule**

- 1990 CAAA added §169B
  - Required research on modeling & monitoring of regional haze
  - Did not revise §169A
- The 1999 Regional Haze Rule required all states (regardless if it doesn’t have a Class I area) to submit a regional haze SIP (including progress reports).
  - It allowed states to join together to implement these rules. Resulting in the states creating 5 Regional Planning Organizations to coordinate technical analysis (monitoring & modeling) & strategy development among its states.

63

2001: EPA established 5 Regional Planning Organizations (RPOs) to coordinate technical analysis & strategy development among its states.

**Regional Planning Organizations**

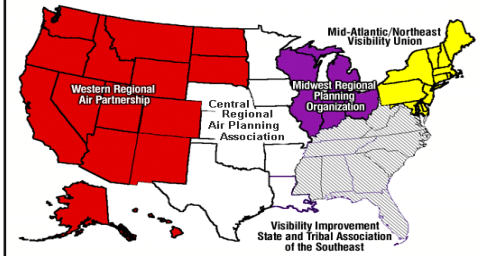

About 75% of the Class I areas are located in WRAP region (116 of 156)

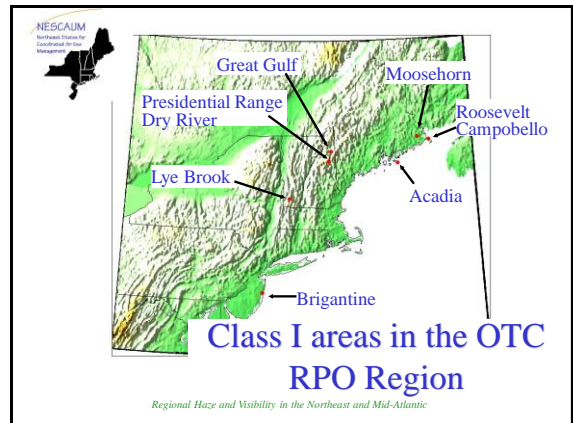

### Visibility Impairment

- **Haze is caused by** tiny particles that scatter and absorb light before it reaches an observer
- **Natural sources** include windblown dust and soot from wildfires.
- **Manmade sources** include motor vehicles, electric utility and industrial fuel burning, and manufacturing operations.



67

### Visibility Impairment

- **Five types of particles** contribute to haze: sulfates, nitrates, organic carbon, elemental carbon, and crustal material. The importance of each type of particle varies across the United States.
- **In humid environments, sulfate particles grow rapidly** to a size that is very efficient at scattering light, thereby exacerbating visibility reductions in the East.

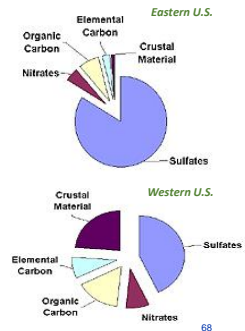

68

### Regional Haze Progress 2014

- **Visibility improvements** have been made in affected areas in the eastern US and some western areas on the 20% haziest days:
  - **Eastern Class I areas:** visibility improvements are a result of the regional haze program, Acid Rain Program, & the Cross-state Air Pollution Rule.
  - **Western Class I areas:** visibility is occasionally impacted by wildfires and dust storms which can mask visibility improvements due to anthropogenic emissions reductions.

69

### Visibility Trends on the 20% Cleanest Days (2000 to 2014)

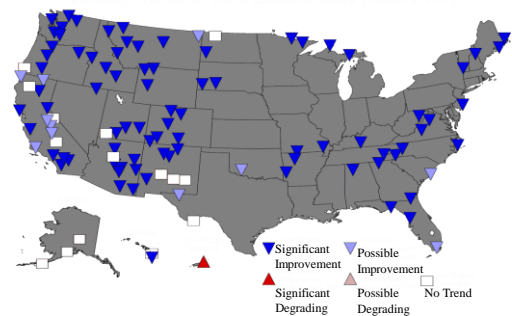

70

### Visibility in selected National Parks and Wilderness Areas in the Eastern U.S. 1992 to 2015

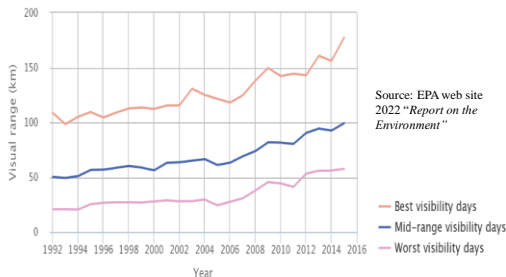

Source: EPA web site 2022 "Report on the Environment"

Coverage: 11 monitoring sites in the eastern U.S. with sufficient data to assess visibility trends from 1992 to 2015.

### Visibility in selected National Parks and Wilderness Areas in the Western U.S. 1992 to 2015

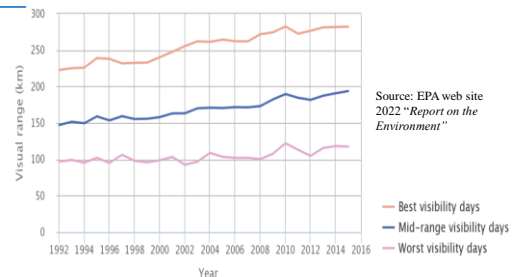

Source: EPA web site 2022 "Report on the Environment"

Coverage: 32 monitoring sites in the western U.S. with sufficient data to assess visibility trends from 1992 to 2015.



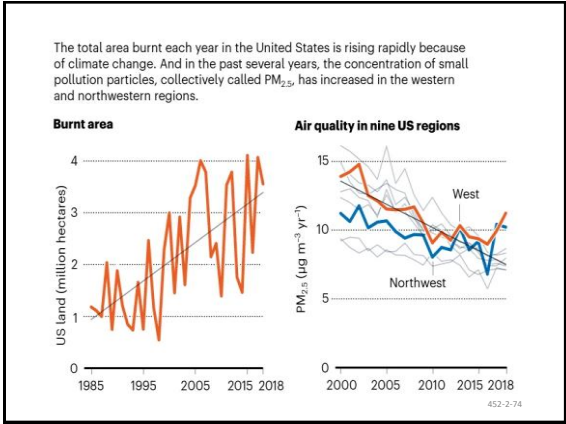
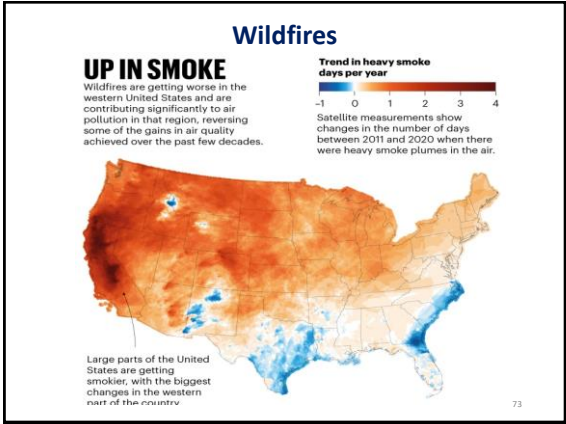



# Chapter 3

## Particle Sizing



3 - 1

### EXAMPLE OF PARTICLE SIZES

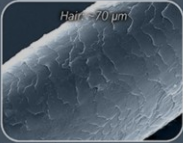

*Hair - 70 μm*

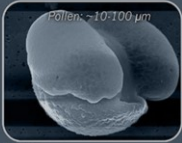

*Pollen - 10-100 μm*

**COARSE PARTICLES**  
Visible coarse dust and sand, leaves, hairs and other large organic particles.

**PM10**  
Smoke, dust, dirt and pollen. Coarser fine dust and bigger organic particles.



*Spores - 1-10 μm*

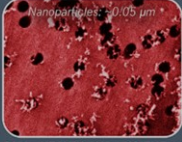

*Nanoparticles - 0.05 μm +*

**PM2.5**  
Bigger spores and other organic particles.

**PM1 - HEALTH AND HYGIENE**  
Very fine dust, combustion particles, nano particles, bacteria, viruses and smaller spores.

3 - 2

### Topics Covered

- Measurement methods
- Data analysis

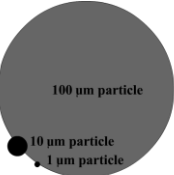

100 μm particle  
10 μm particle  
1 μm particle

Figure 3-2. 1μm and 10μm particles compared to a 100μm particle.

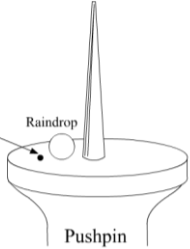

Raindrop  
100μm particle  
Pushpin

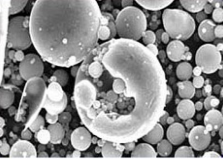

3 - 3

- Here are some useful conversions for particle sizes:
- Micrometer = (1/1,000,000) Meter
- Micrometer = (1/10,000) centimeter
- 1,000μm = 1 mm = 0.1 cm

### Particle Size and Air Pollution Control

Diameter (μm)	Volume (cm <sup>3</sup> )	Area (cm <sup>2</sup> )
0.1	5.23 x 10 <sup>-16</sup>	3.14 x 10 <sup>-10</sup>
1.0	5.23 x 10 <sup>-13</sup>	3.14 x 10 <sup>-8</sup>
10.0	5.23 x 10 <sup>-10</sup>	3.14 x 10 <sup>-6</sup>
100.0	5.23 x 10 <sup>-7</sup>	3.14 x 10 <sup>-4</sup>
1,000.0	5.23 x 10 <sup>-4</sup>	3.14 x 10 <sup>-2</sup>

3 - 5

### Particle Shapes

- Particles vary in geometry: for example, perfect spheres such as condensed vapors, cylindrical or flat filaments like cotton or asbestos fibers for which the ratio of length to width is large.
- They can be platelets such as silica or mica or feathery agglomerates like soot and irregularly shaped fragments such as coal dust, foundry sand, or metal grinding particles.
- When particles are not spheres the drag may be quite different even for the same particle mass.

### Particle Size?

Solid Sphere    Hollow Sphere    Solid Irregular    Flake

Fiber    Condensation Floc    Aggregate

3 - 7

### Aerodynamic Diameter

The diameter of a sphere with a density of 1 g/cm<sup>3</sup> that has the same falling velocity in air as the actual particle

$$d_p = d \sqrt{\rho_p C_c}$$

where:  
 d<sub>p</sub> = aerodynamic particle diameter (μm)  
 d = physical diameter (μm)  
 ρ<sub>p</sub> = particle density (g/cm<sup>3</sup>)  
 C<sub>c</sub> = Cunningham slip correction

3 - 8

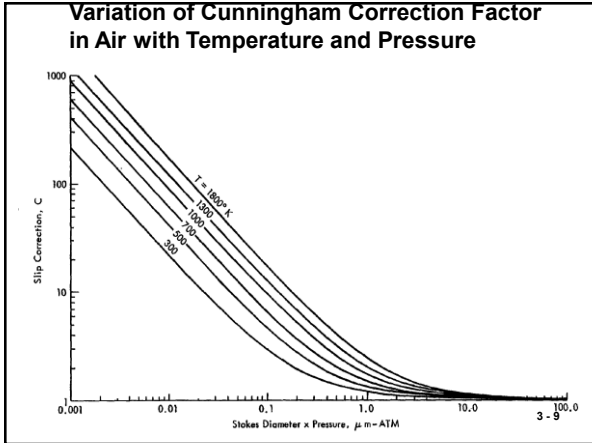

### Aerodynamic Diameters of Differently Shaped Particles

	Solid sphere	ρ <sub>p</sub> = 2.0 g/cm <sup>3</sup> d = 1.4 μm	d <sub>p</sub> = 2.0 μm
	Hollow sphere	ρ <sub>p</sub> = 0.50 g/cm <sup>3</sup> d = 2.80 μm	
	Irregular shape	ρ <sub>p</sub> = 2.3 g/cm <sup>3</sup> d = 1.3 μm	

3 - 10

### Measurement Methods

- Microscopy
- Optical counters
- Electrical aerosol analyzer
- Bahco analyzer
- Cascade impactors

3 - 11

### Ideal Measuring Device

- Measure the exact size of each particle
- Determine the composition of each particle
- Report real-time data instantaneously

3 - 12

Figure 3-12. Comparison of particle sizing devices

Device	Size	Time	Composition
Ideal	◁	◁	◁
Microscope	◁	⌈	
Optical counter	◁	◁	
EAA	◁	◁	
Bahco counter	◁	⌈	◁
Impactor	◁	⌈	◁

- ◁ Single particle level
- ◁ Discrete ranges
- ⌈ Intergrated averaging process

3 - 13

### Microscopy

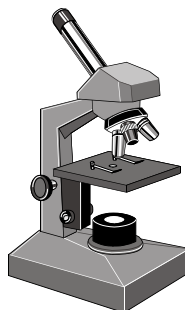

- Polarized Light Microscopy
- Scanning Electron Microscopy
- Energy Dispersive X-Ray Spectroscopy

3 - 14

### Micrograph of a Particles Collected From Cascade Impactor

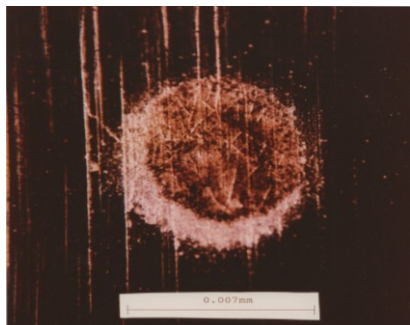

3 - 15

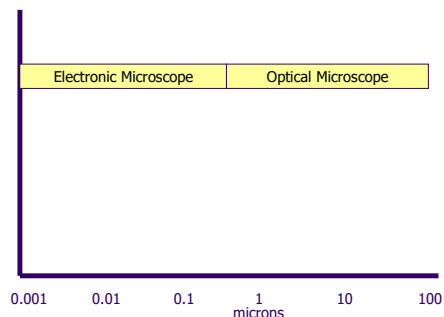

3 - 16

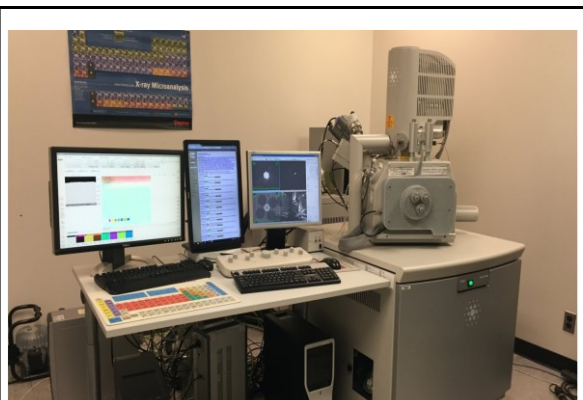

FEI Quanta 600 FEG Environmental Scanning Electron Microscope (ESEM) 3 - 17

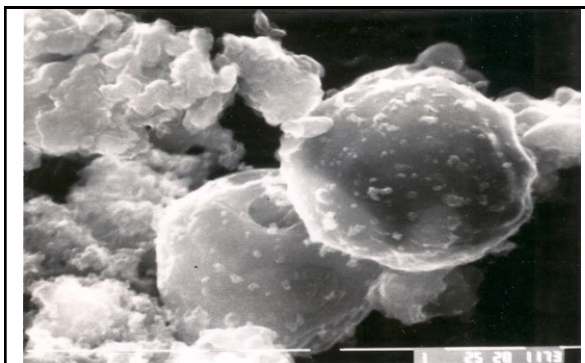

Micrograph of two 2.5-micrometer particles collected from ambient air. (*Electron Microscopy and Elemental Analysis of Fractionated Atmospheric Particles for Source Identification*, William J. Franek, Ph.D. Thesis, University of Illinois-Chicago, Chicago, IL, 1992.)

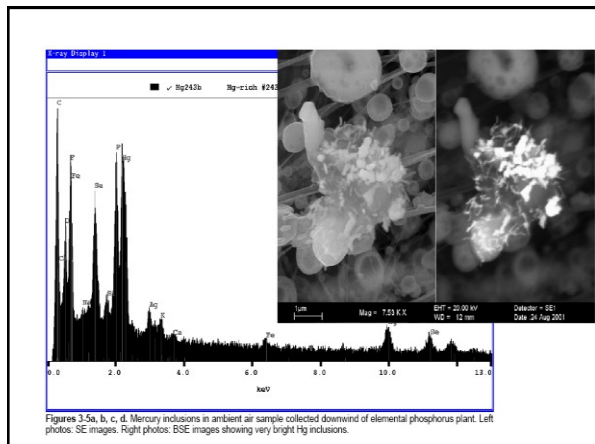

Figures 3-5a, b, c, d. Mercury inclusions in ambient air sample collected downwind of elemental phosphorus plant. Left photos: SE images. Right photos: BSE images showing very bright Hg inclusions.

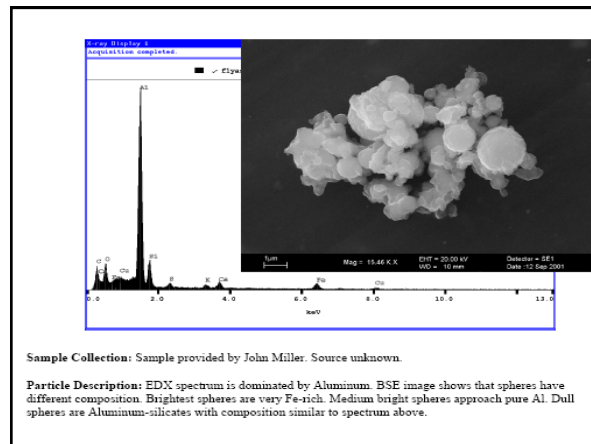

Sample Collection: Sample provided by John Miller. Source unknown.

Particle Description: EDX spectrum is dominated by Aluminum. BSE image shows that spheres have different composition. Brightest spheres are very Fe-rich. Medium bright spheres approach pure Al. Dull spheres are Aluminum-silicates with composition similar to spectrum above.

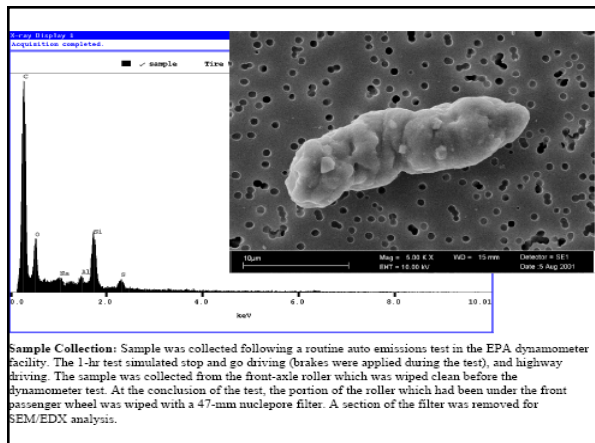

Sample Collection: Sample was collected following a routine auto emissions test in the EPA dynamometer facility. The 1-hr test simulated stop and go driving (brakes were applied during the test), and highway driving. The sample was collected from the front-axle roller which was wiped clean before the dynamometer test. At the conclusion of the test, the portion of the roller which had been under the front passenger wheel was wiped with a 47-mm nuclepore filter. A section of the filter was removed for SEM/EDX analysis.

EPA # 600/R-02/070  
September 2002

### Guidelines for the Application of SEM/EDX Analytical Techniques to Particulate Matter Samples

by  
Robert D. Willis and Fredrick T. Blanchard  
ManTech Environmental Technology, Inc.  
Research Triangle Park, NC 27709  
and  
Teri L. Conner  
National Exposure Research Laboratory  
U.S. Environmental Protection Agency  
Research Triangle Park, NC 27711  
Contract 68-D-00-206

Project Officer  
Curtis Morris  
Human Exposure and Atmospheric Sciences Division  
National Exposure Research Laboratory

Work Assignment Manager  
Teri L. Conner  
National Exposure Research Laboratory  
U.S. Environmental Protection Agency  
Research Triangle Park, NC 27711

National Exposure Research Laboratory  
Office of Research and Development  
U.S. Environmental Protection Agency  
Research Triangle Park, NC 27711

3 - 22

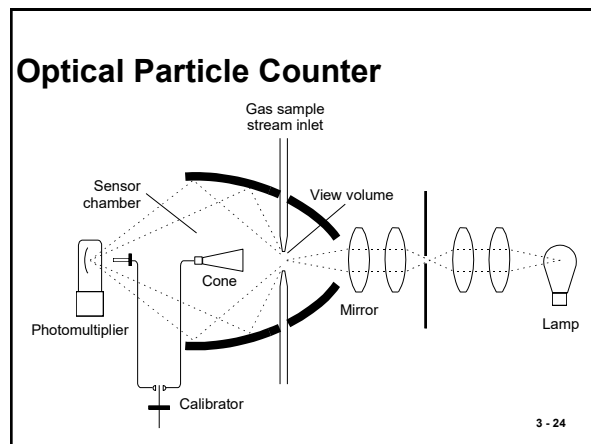
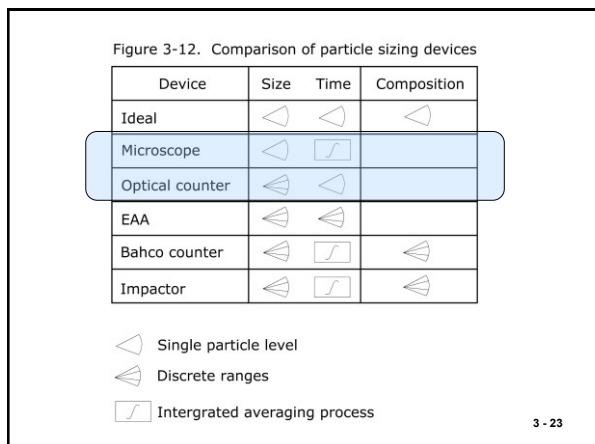

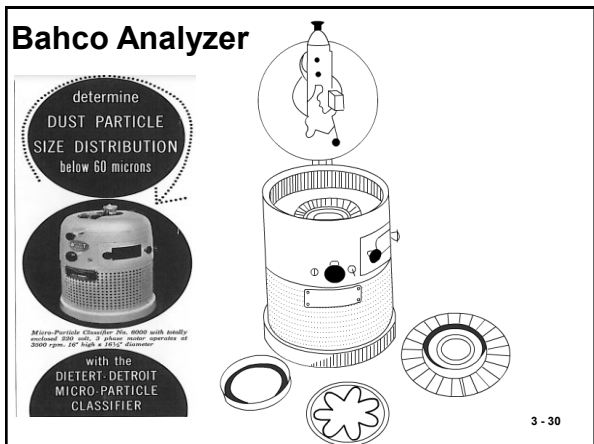
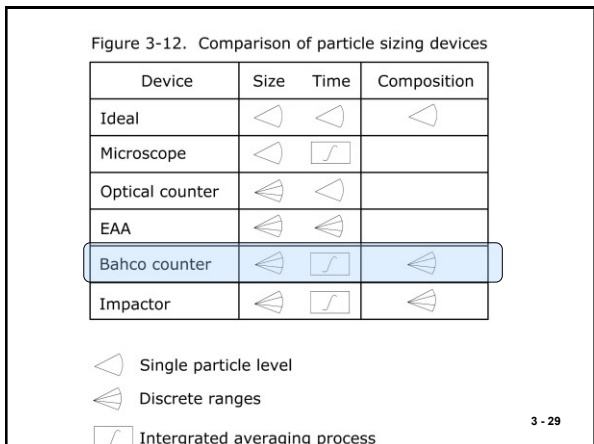
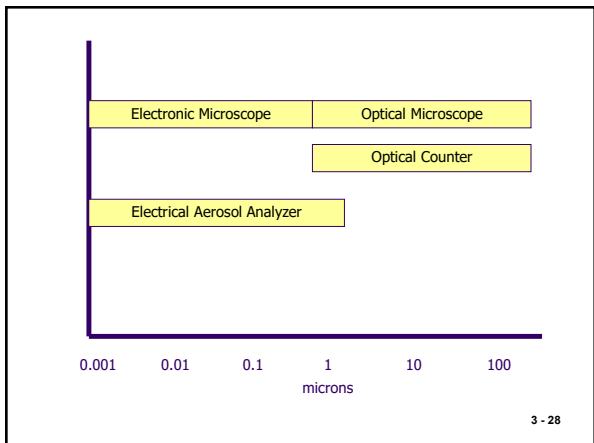
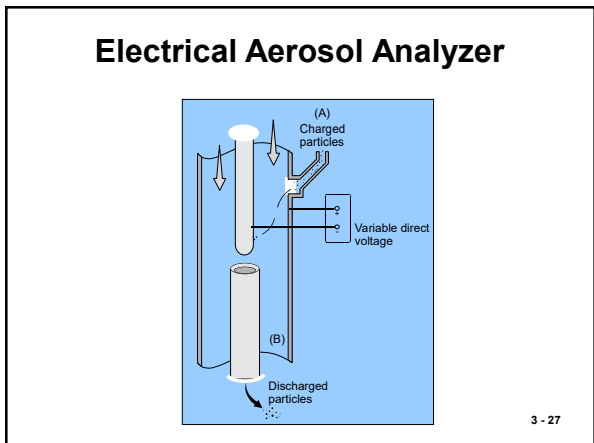
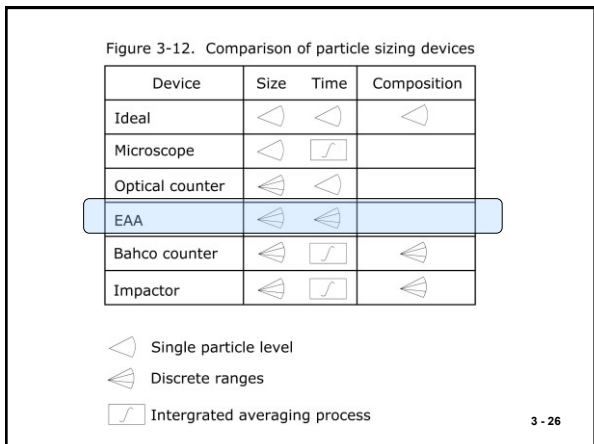
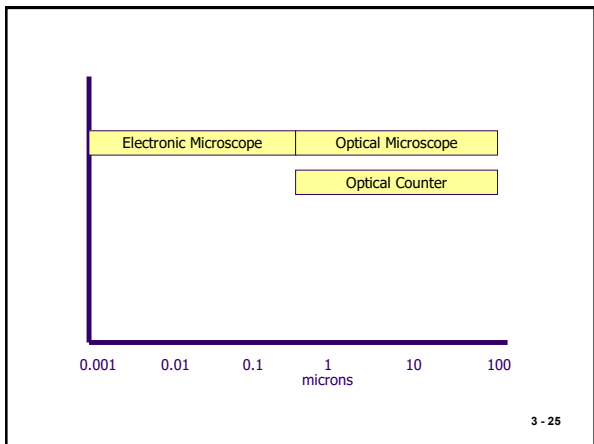

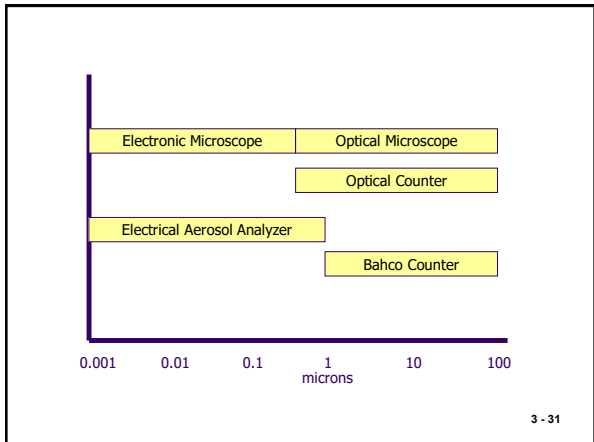

3 - 31

Figure 3-12. Comparison of particle sizing devices

Device	Size	Time	Composition
Ideal	◁ ▷	◁ ▷	◁ ▷
Microscope	◁ ▷	◻	
Optical counter	◁ ▷	◁ ▷	
EAA	◁ ▷	◁ ▷	
Bahco counter	◁ ▷	◻	◁ ▷
Impactor	◁ ▷	◻	◁ ▷

- ◁ ▷ Single particle level
- ◁ ▷ Discrete ranges
- ◻ Intergrated averaging process

3 - 32

Cascade Impactor

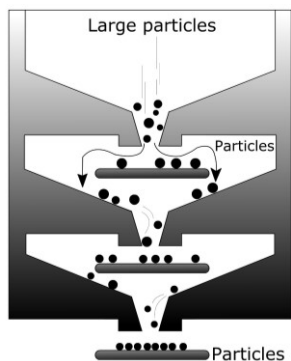

3 - 33

Cascade Impactors In-stack

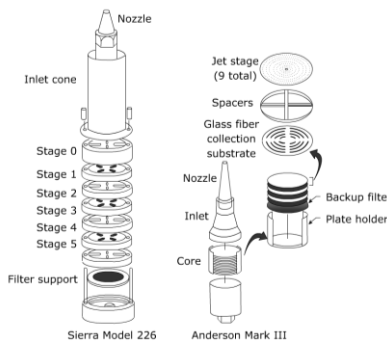

3 - 34

Pollution Control Systems Mark V Impactor Stage Cuts (@300°F, 29.00 in Hg dry air) for Multiple Flow Rates

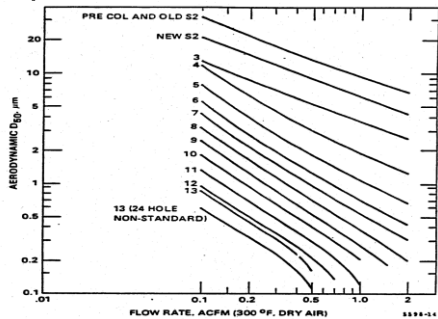

3 - 35

Test Method: 2001-08-28 Method 501 Determination of Size Distribution of Particulate Matter from Stationary Sources (ca.gov)

Five Stage In-stack Particle Separator Cyclones

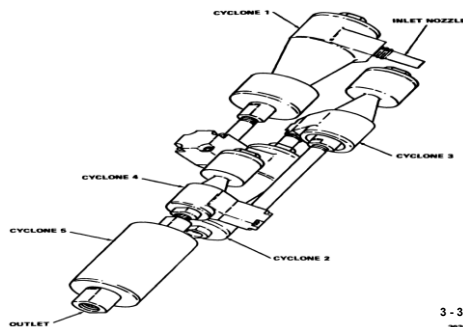

3 - 36



PM-10 Sampling at a Cotton Gin



Size Range Capabilities of Measuring Devices

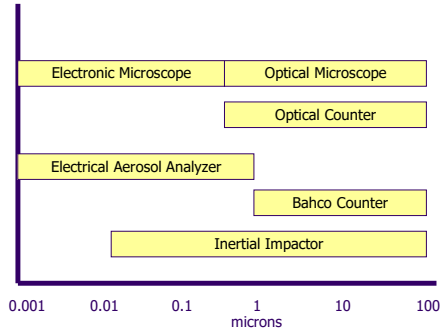

3 - 38

Particle Size Distributions

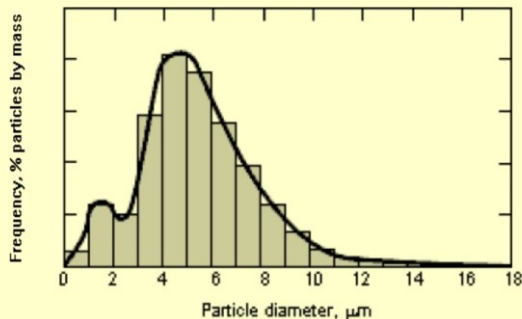

3 - 39

Histogram

● A histogram is one of the simplest ways to display a particle size distribution. It is a particle frequency distribution that shows the percentage of particles found in each size range. Frequency can be plotted (on the Y-axis) by number count, surface area, or mass. The skewed distribution shown in the next slide is typically found in air pollution control sampling and emission measurement.

Data Analysis

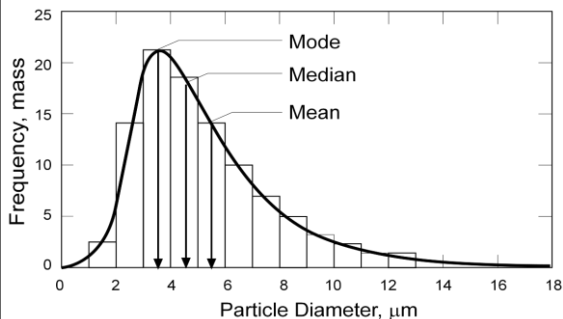

3 - 41

Histogram of Lognormal Particle Size Distribution

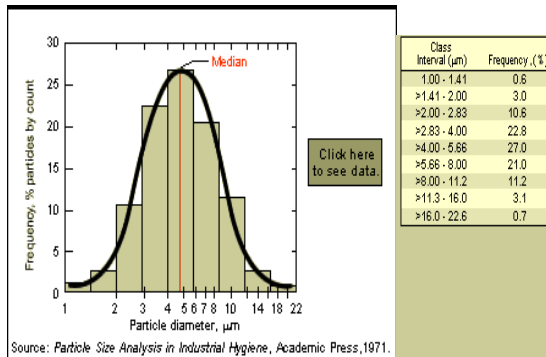

### Data Analysis

- The median, arithmetic mean, and mode help characterize the arithmetic mass distribution. The **median particle size (mass median particle diameter)** is the particle diameter that divides the frequency distribution in half; fifty percent of the aerosol mass has particles with a larger diameter, and fifty percent of the aerosol mass has particles with a smaller diameter.
- The **arithmetic mean diameter**, usually simply termed the mean diameter, is the arithmetic average particle diameter of the distribution. The value of the arithmetic mean is sensitive to the quantities of particulate matter at the extreme lower and upper ends of the distribution.
- The **mode** represents the value that occurs most frequently in a distribution. In particle size distributions, the mode is the particle diameter that occurs most frequently.

3 - 43

### Lognormal Size Distribution

- When the particle diameters from the previous slide are plotted on a logarithmic scale against the frequency of occurrence, a bell-shaped curve is generated.
- As shown in the next slide, the particle size categories are altered to produce equidistant ranges when plotted on a logarithmic basis.
- This bell-shaped histogram is called a **lognormal curve**. For many anthropogenic (manmade) sources, the observed particulate matter distribution approximates a lognormal distribution.
- Therefore, it is often beneficial to work with particle size distributions on a logarithmic basis.

### Log-Normal Distribution

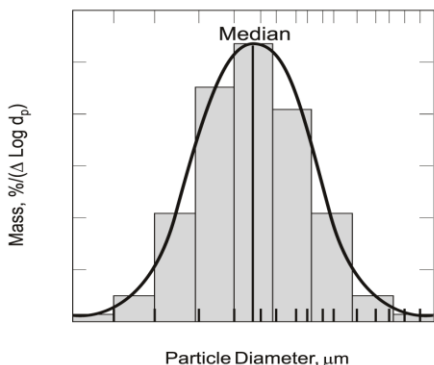

3 - 45

### Log-Normal Distribution

- The terms, **geometric mean diameter** and **geometric standard deviation**, are substituted for arithmetic mean diameter and standard deviation when incorporating logarithms of numbers. When the frequency of the particle size distribution is based on mass, the more specific term **geometric mass mean diameter** is used.

### Log-Probability Plots

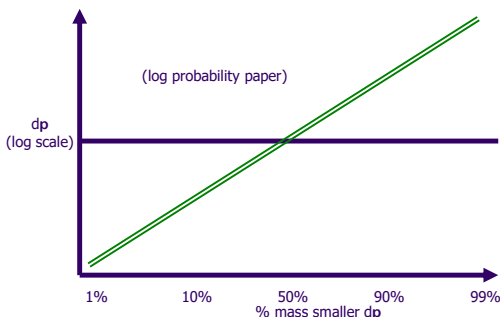

3 - 47

### Size Distribution (Log Probability Plot)

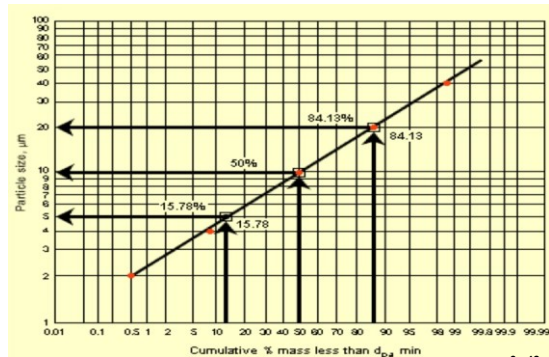

3 - 48

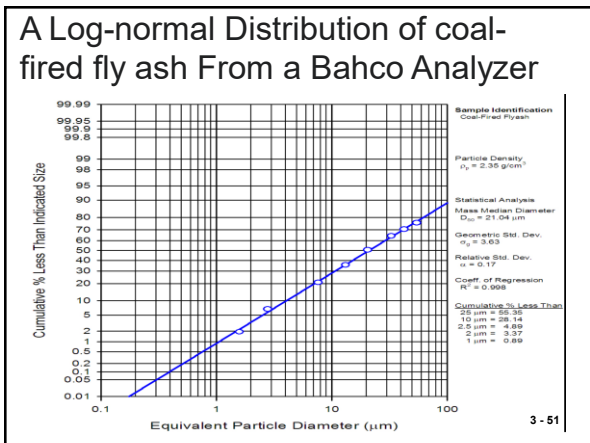
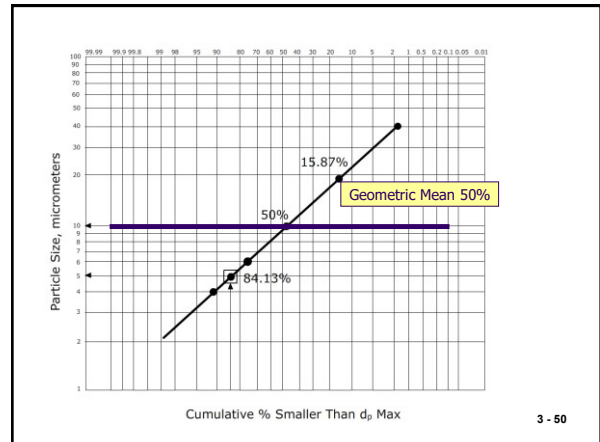
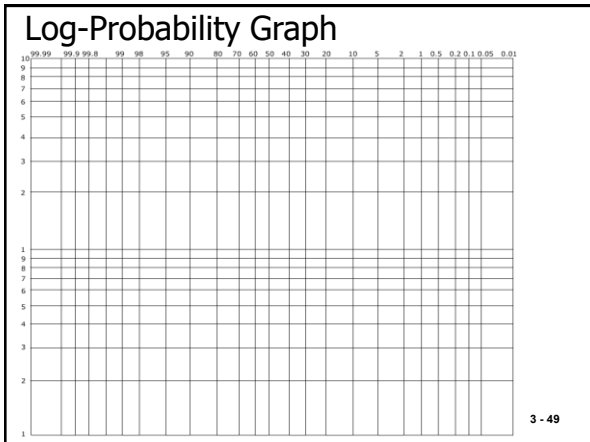

- A distribution with a broad range of sizes has a larger geometric standard deviation ( $\sigma_g$ ) than one in which the particles are relatively similar in size.
  - When the data are plotted in terms of the cumulative percent larger than size, the geometric standard deviation is determined by dividing the particle size at the 15.87 percent probability (-1 standard deviations from the mean) by the geometric mean size or by dividing the geometric mean size by the particle size at the 84.13 percent probability (+1 standard deviations from the mean)
- 3 - 52

**Geometric Standard Deviation**

$$\sigma_g = \frac{d_{15.87}}{d_{50}} \quad \text{or} \quad \sigma_g = \frac{d_{50}}{d_{84.13}}$$

Where:

- $\sigma_g$  = geometric standard deviation of particle mass distribution
- $d_{50}$  = mass mean particle diameter
- $d_{15.87}$  = particle diameter which 15.87% of the mass is larger than
- $d_{84.13}$  = particle diameter which 84.13% of the mass is larger than

3 - 53

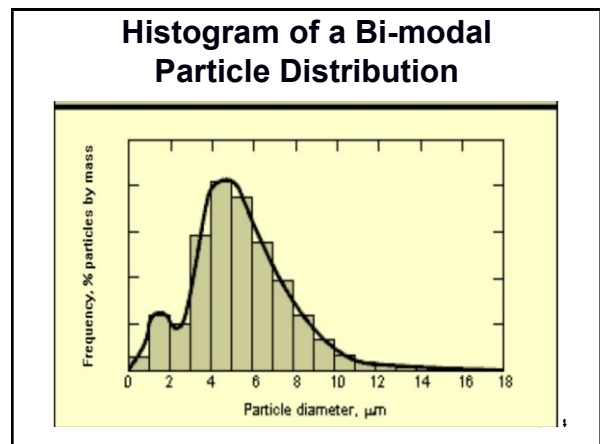

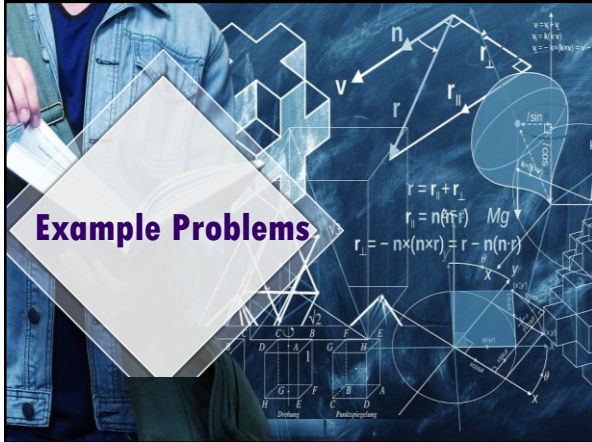

**Example Problems**

**Example 3-1**

Determine the mass mean diameter and the geometric standard deviation of the particle collection represented by the following distribution:

Size Range (gm)	Mass (mg)
<2	1.0
2 to 4	14.5
4 to 6	24.7
6 to 10	59.8
10 to 20	68.3
20 to 40	28.9
>40	2.8

3 - 56

**Solution...** Refer to the table. Determine the total mass and calculate the percentage in each size range.

2. Starting with the size range for the smallest particles (<2 mm), subtract the percent mass in that range (0.50%) from 100.00 to determine the cumulative percent mass greater than 2 mm (99.50%).

3. For each subsequent size range, subtract the percent mass in that range from the cumulative percent mass of the previous size range to determine the cumulative percent mass less than  $d_p$  max for that size range.

Example Particle Size Data			
Size Range ( $\mu\text{m}$ )	Mass (mg)	% Mass in Size Range	Cumulative % Mass Less Than $d_p$ max
<2	1.0	0.50	99.50
2 to 4	14.5	7.25	92.25
4 to 6	24.7	12.35	79.90
6 to 10	59.8	29.90	50.00
10 to 20	68.3	34.15	15.85
20 to 40	28.9	14.45	1.40
>40	2.8	1.40	---
TOTAL	200.0	100.0	

For example, for the 2-4  $\mu\text{m}$  size range, 99.50% - 7.25% = 92.25%, the cumulative percent mass less than 4 mm.

**Example 3-1**

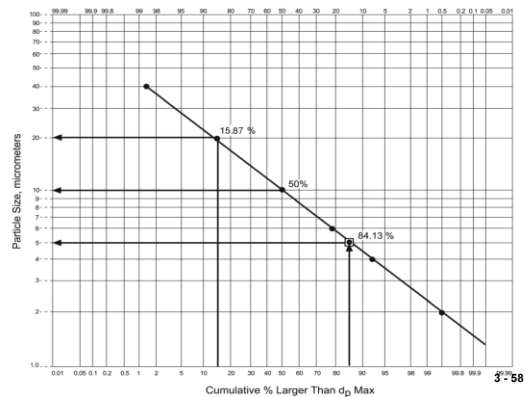

3-58

**Finally...**

The mass mean particle diameter is found at the 50th percentile and is 10 mm. The geometric standard deviation is calculated from:

$$\sigma_g = \frac{d^{15.87}}{d^{50}} = \frac{20\mu\text{m}}{10\mu\text{m}} = 2.0$$

or

$$\sigma_g = \frac{d^{50}}{d^{84.13}} = \frac{10\mu\text{m}}{5\mu\text{m}} = 2.0$$

3 - 59

Plot  $d_p$ max versus Cumulative Percent Mass Smaller Than  $d_p$ max on log-probability graph:

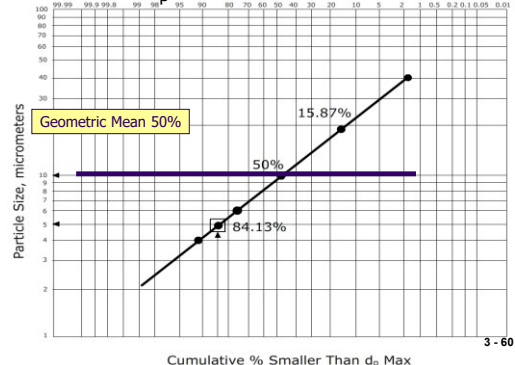

3 - 60

**Review Questions**

1. Calculate the aerodynamic diameter of a spherical particle having a true diameter of 2 μm and a density of 2.7 g/cm<sup>3</sup>.

Solution:

Assume that the Cunningham slip correction factor is 1.

$$d_p = d \sqrt{p_p C_c} = 2 \sqrt{(2.7)(1.0)} = 3.29 \mu\text{m}$$

3 - 61

**Review Questions**

2. Given the following distributions:
  - Is either of the distributions lognormal?
  - If yes, what is the geometric mass mean diameter and the geometric standard deviation?

Size Range (μm)	Sample A Mass (mg)	Sample B Mass (mg)
<0.6	25.50	8.50
0.6 to 1.0	33.15	11.05
1.0 to 1.2	17.85	7.65
1.2 to 3.0	102.00	40.80
3.0 to 8.0	63.75	15.30
8.0 to 10.0	5.10	1.69
>10.0	7.65	0.01

3 - 62

**Solution #2 (a)**

Size Range (gm)	Mass (mg)	Percent Mass in Size Range	Cumulative Percent Mass Greater Than d <sub>p,max</sub>
<0.6	25.50	10	90
0.6 to 1.0	33.15	13	77
1.0 to 1.2	17.85	7	70
1.2 to 3.0	102.00	40	30
3.0 to 8.0	63.75	25	5
8.0 to 10.0	5.10	2	3
>10.0	7.65	3	---
TOTAL	255.0	100.0	

3 - 63

*But wait there is more*

**Solution #2 (b)**

Size Range (gm)	Mass (mg)	Percent Mass in Size Range	Cumulative Percent Mass Greater Than d <sub>p,max</sub>
<0.6	8.50	10	90
0.6 to 1.0	11.05	13	77
1.0 to 1.2	7.65	9	68
1.2 to 3.0	40.80	48	20
3.0 to 8.0	15.30	18	2
8.0 to 10.0	1.69	1.99	0.01
>10.0	0.01	0.01	---
TOTAL	85.0	100.0	

3 - 64

*But wait there is more*

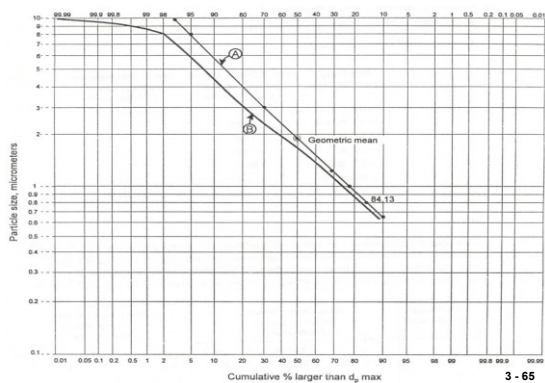

3 - 65

**Next, plot them**

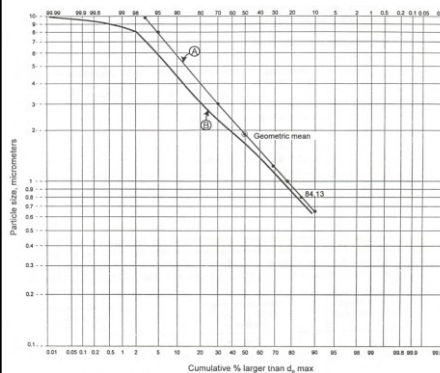

- A) Is lognormal
- B) Is not lognormal

3 - 66

*But wait there is more*

And finally...

The geometric mass mean diameter and the geometric standard deviations for Sample A are:

$$d_{50} = 1.9 \mu\text{m}$$

$$\sigma_g = \frac{d_{50} = 1.9 \mu\text{m}}{d_{84.13} = 0.8 \mu\text{m}} = 2.4$$

3 - 67

If the information presented was smaller than the  $d_p$  the plot would look this way

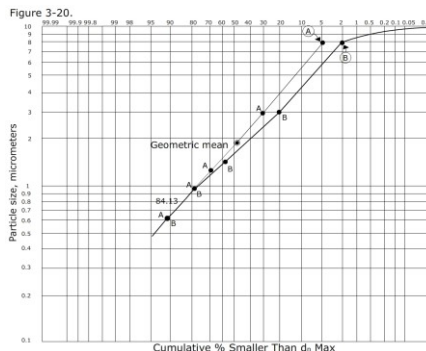

- A) Is lognormal
- B) Is not lognormal

3 - 68

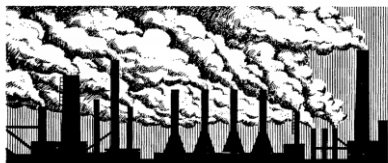

PARTICULATE POLLUTANT SYSTEM STUDY  
VOLUME III - HANDBOOK OF EMISSION PROPERTIES



3 - 69

Stationary Source Control Techniques Document  
for Fine Particulate Matter

EPA CONTRACT NO. 68-D-98-026  
WORK ASSIGNMENT NO. 0-08

Prepared for:

Mr. Kenneth Woodard  
Integrated Policy and Strategies Group (MD-15)  
Air Quality Strategies and Standards Division  
U.S. Environmental Protection Agency  
Research Triangle Park, North Carolina 27711

October 1998

Submitted by:

EC/R Incorporated  
Timberlyne Center  
1129 Weaver Dairy Road  
Chapel Hill, North Carolina 27514

3 - 70

## Chapter 4

---

# Particle Collection Mechanisms



1

## Collection Mechanisms

- Gravitational settling • A fabric filter uses *inertial impaction, Brownian motion and electrostatic attraction* to capture particles in the size range of 100 μm to less than 0.01 μm onto the dust layers present on the bags.
- Centrifugal inertial force
- Inertial impaction
- Brownian motion
- Electrostatic attraction
- Thermophoresis
- Diffusiophoresis
- In ESPs, the dust is deposited on collection plates by *electrostatic forces*. The initial capture of particles is efficient over the entire size range of 0.1 μm to 100 μm.

2

## Particle Motion

$$\Sigma F = m_p a_p = m_p \frac{dv_p}{dt}$$

where

- ΣF = sum of all forces acting on the particle (g·cm/sec<sup>2</sup>)
- m<sub>p</sub> = mass of the particle (g)
- a<sub>p</sub> = acceleration of the particle (cm/sec<sup>2</sup>)
- v<sub>p</sub> = velocity of the particle (cm/sec)
- t = time (sec)

3

*cgs units given, but any consistent set of units is ok*

## English System Units

$$\Sigma F = \frac{m_p a_p}{g_c}$$

where

- ΣF = sum of all forces acting on the particle (lb<sub>f</sub>)
- m<sub>p</sub> = mass of the particle (lb<sub>m</sub>)
- a<sub>p</sub> = acceleration of the particle (ft/sec<sup>2</sup>)

$$g_c = 32.2 \frac{lb_m ft}{lb_f sec^2}$$

Where g<sub>c</sub> is needed to convert pounds of mass to pounds of force in the English system

## Gravitational Settling

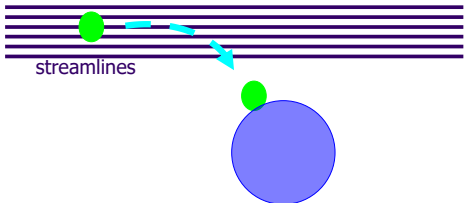

5

## Forces on a Particle

- Gravitational force
- Buoyant force
- Drag force

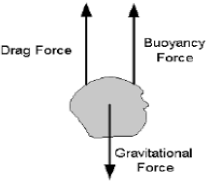

To determine the extent to which a particle can be collected by gravitational settling, it is necessary to calculate the forces exerted on the material. These forces are the gravitational force, F<sub>G</sub>, the buoyant force, F<sub>B</sub>, and the drag force, F<sub>D</sub>.

6

### Gravitational Force

$$F_G = m_p g = \rho_p V_p g$$

To simplify calculations, particles are assumed to be spheres.

$$V_p = \frac{\pi d_p^3}{6} \quad V_p = \text{volume of particle}$$

$$F_G = \frac{\pi d_p^3 \rho_p g}{6}$$

### Buoyant Force

Acting to resist the downward force of gravity is the upward force of buoyancy. This force occurs because of the gas displaced by the particle.

$$F_B = m_g g = \rho_g V_p g$$

$$F_B = \frac{\pi d_p^3 \rho_g g}{6}$$

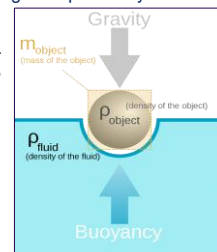

The buoyant force is comparatively very small and can be neglected because the gas density  $\sim 10^{-2}$  lbm/ft<sup>3</sup> (used for buoyancy force) is several orders of magnitude smaller than the particle density  $\sim 10^2$  lbm/ft<sup>3</sup> (used for gravitational force).

### Drag Force ( $F_D$ )

$$F_D = \frac{\pi d_p^2 \rho_g v_p^2 C_D}{8}$$

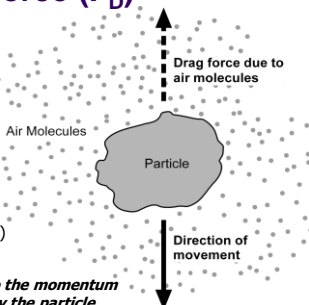

$d_p$  = diameter of particle (cm)  
 $\rho_g$  = density of gas (gm/cm<sup>3</sup>)  
 $v_p$  = velocity of particle (cm/sec)  
 $C_D$  = drag coefficient (dimensionless)

The drag force produced is equal to the momentum per unit time imparted to the gas by the particle.

When a particle moves through a gas, it displaces the gas immediately in front of it, imparting momentum to the gas. A portion of the particle's velocity,  $v_p$ , is transferred by momentum to the gas as gas velocity,  $v_g$ . The amount of energy imparted from  $v_p$  to  $v_g$  is related to a friction factor which is called the drag coefficient,  $C_D$ .

### Drag Coefficient ( $C_D$ )

$C_D$  is a function of the particle Reynolds number

$$Re_p = \frac{d_p v_p \rho_g}{\mu_g}$$

$Re_p$  = particle Reynolds number (dimensionless)

$d_p$  = particle diameter (cm)

$v_p$  = particle velocity relative to the gas (cm/sec)

$\rho_g$  = gas density (g/cm<sup>3</sup>)

$\mu_g$  = gas viscosity (g/(cm·sec))

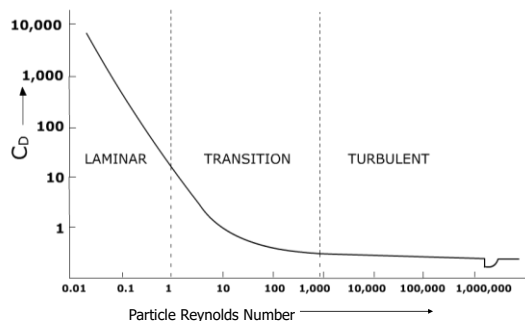

- Laminar ( $Re_p < 1$ )

$$C_D = \frac{24}{Re_p}$$

- Transition ( $1 < Re_p < 1,000$ )

$$C_D = \frac{18.5}{Re_p^{0.6}}$$

- Turbulent ( $Re_p > 1,000$ )

$$C_D = 0.44$$

Mathematical expressions relating the values of  $C_D$  and  $Re_p$  can be derived from the data illustrated in previous figure.



### Laminar Regime: Development of "Cunningham Slip Correction Factor"

$d_p > 3\mu\text{m}$        $d_p < 3\mu\text{m}$

If the particles are smaller than 3  $\mu\text{m}$  in diameter, the gas appears as individual molecules. These small particles are able to slip between the gas molecules and fall faster than relationships developed for continuous media predict (previous slide). To correct for this, Cunningham deduced that the drag coefficient should be reduced for small particles in the laminar region by a term called the Cunningham slip correction factor,  $C_c$ .

### Laminar Regime Drag Coefficient

$$C_D = \frac{24}{Re_p C_c}$$

$C_c$  is the Cunningham slip correction factor

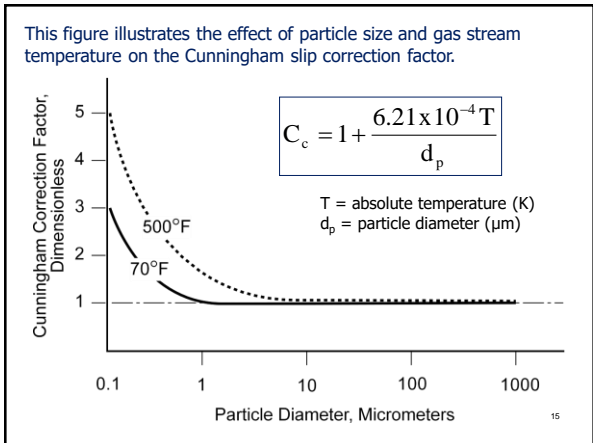

The drag force for each region can now be calculated by substituting ( $C_D$ ) drag coefficient Equation (slides 12 & 14) into general drag force Equation (slide #9).

- Laminar ( $Re_p < 1$ )**

$$F_D = \frac{3\pi\mu_g v_p d_p}{C_c}$$

Note: Cunningham slip correction factor ( $C_c$ ) only applies in laminar flow
- Transition ( $1 < Re_p < 1,000$ )**

$$F_D = 2.31\pi(d_p v_p)^{1.4} \mu_g^{0.6} \rho_g^{0.4}$$
- Turbulent ( $Re_p > 1,000$ )**

$$F_D = 0.055\pi(d_p v_p)^2 \rho_g$$

### Terminal Settling Velocity

$$F_G - F_D = 0$$

$$F_G = F_D$$

$$F_G = \frac{\pi d_p^3 \rho_p g}{6}$$

$$F_D \text{ comes from previous slide - depends on flow type}$$

### Terminal Settling Velocity ( $V_t$ )

Laminar Regime

$$V_t = \frac{g C_c \rho_p d_p^2}{18\mu_g}$$

When the drag force equals the gravitational force, the particle will no longer accelerate. If the particle is not accelerating, it is at a constant velocity. This constant velocity, where all the forces balance, is called the *terminal settling velocity*.

### Terminal Settling Velocity

Transition Regime

$$V_t = \frac{0.153 g^{0.71} \rho_p^{0.71} d_p^{1.14}}{\mu_g^{0.43} \rho_g^{0.29}}$$

19

### Terminal Settling Velocity

Turbulent Regime

$$V_t = 1.74 \left( \frac{g \rho_p d_p}{\rho_g} \right)^{0.5}$$

20

### Determination of Flow Regime

$$K = d_p \left( \frac{g \rho_p \rho_g}{\mu_g^2} \right)^{0.33}$$

where

- g = acceleration of particle due to gravity (980 cm/sec<sup>2</sup>)
- ρ<sub>p</sub> = particle density (g/cm<sup>3</sup>)
- μ<sub>g</sub> = gas viscosity (g/(cm·sec))
- d<sub>p</sub> = physical particle diameter (cm)
- ρ<sub>g</sub> = gas density (g/cm<sup>3</sup>)

21

*Don't get wrapped up in the units; any consistent set of units is ok.*

### K Values

Laminar region	K < 2.62
Transitional region	2.62 < K < 69.12
Turbulent region	K > 69.12

22

#### Example 4-1

(the density of air at 20°C is 1.20 x 10<sup>-3</sup> g/cm<sup>3</sup> and the viscosity is 1.80 x 10<sup>-4</sup> g/(cm·sec))

Calculate the terminal settling velocity in 20°C air of a 45 μm diameter particle with a density of 1 g/cm<sup>3</sup>.

**Solution**

Calculate K to determine the flow region:

$$K = d_p \left( \frac{g \rho_p \rho_g}{\mu_g^2} \right)^{0.33} = 45 \times 10^{-4} \text{ cm} \left[ \frac{\left( 980 \frac{\text{cm}}{\text{sec}^2} \right) \left( 1.0 \frac{\text{g}}{\text{cm}^3} \right) \left( 1.20 \times 10^{-3} \frac{\text{g}}{\text{cm}^3} \right)}{\left( 1.80 \times 10^{-4} \frac{\text{g}}{\text{cm} \cdot \text{sec}} \right)^2} \right]^{0.33} = 1.41$$

Therefore, the flow region is laminar.

Calculate the terminal settling velocity:

Assume C<sub>c</sub> = 1.0

$$V_t = \frac{g C_c \rho_p d_p^2}{18 \mu_g} = \frac{\left( 980 \frac{\text{cm}}{\text{sec}^2} \right) (1.0) \left( 1.0 \frac{\text{g}}{\text{cm}^3} \right) \left( 45 \times 10^{-4} \text{ cm} \right)^2}{18 \left( 1.80 \times 10^{-4} \frac{\text{g}}{\text{cm} \cdot \text{sec}} \right)} = 6.13 \frac{\text{cm}}{\text{sec}}$$

23

#### Example 4-2

(the density of air at 20°C is 1.20 x 10<sup>-3</sup> g/cm<sup>3</sup> and the viscosity is 1.80 x 10<sup>-4</sup> g/(cm·sec))

Calculate the terminal settling velocity in 20°C air of a 2 μm diameter particle with a density of 1 g/cm<sup>3</sup>.

**Solution**

Calculate K to determine the flow region:

$$K = d_p \left( \frac{g \rho_p \rho_g}{\mu_g^2} \right)^{0.33} = 2 \times 10^{-4} \text{ cm} \left[ \frac{\left( 980 \frac{\text{cm}}{\text{sec}^2} \right) \left( 1.0 \frac{\text{g}}{\text{cm}^3} \right) \left( 1.20 \times 10^{-3} \frac{\text{g}}{\text{cm}^3} \right)}{\left( 1.80 \times 10^{-4} \frac{\text{g}}{\text{cm} \cdot \text{sec}} \right)^2} \right]^{0.33} = 0.06$$

Therefore, the flow region is laminar.

Next, calculate the Cunningham slip correction factor:

$$C_c = 1 + \frac{6.21 \times 10^{-4} T}{d_p} = 1 + \frac{6.21 \times 10^{-4} (293\text{K})}{2 \mu\text{m}} = 1.09$$

24

**Example 4-2**

Calculate the terminal settling velocity in 20°C air of a 2 μm diameter particle with a density of 1 g/cm<sup>3</sup>.

Then...

Calculate the terminal settling velocity:

$$v_t = \frac{g C_c \rho_p d_p^2}{18 \mu_g} = \frac{\left(980 \frac{\text{cm}}{\text{sec}^2}\right) (1.09) \left(1.0 \frac{\text{g}}{\text{cm}^3}\right) (2 \times 10^{-4} \text{cm})^2}{18 \left(1.80 \times 10^{-4} \frac{\text{g}}{\text{cm} \cdot \text{sec}}\right)} = 0.013 \frac{\text{cm}}{\text{sec}}$$

25

These data indicate that the terminal settling velocities are virtually negligible for particles less than 10 μm, moderate for particles in the size range of 10-80 μm, and relatively fast only for particles larger than 80 μm.

Terminal Settling Velocities of Unit Density Spheres at 25° C		
Particle Size (μm)	Terminal Settling Velocity at 25 C (cm/sec)	Flow Condition
0.1	0.000087	Laminar
1.0	0.0035	Laminar
10.0	0.304	Laminar
50.0	7.5	Laminar
80.0	19.3	Laminar
100	31.2	Transitional
200	68.8	Transitional
1,000	430.7	Transitional
10,000	1,583	Turbulent
100,000	5,004	Turbulent

It is for this reason that air pollution control devices that employ only gravitational settling to accomplish initial separation are limited to pre-cleaners that are designed to reduce the large particle fraction before entering fans or the primary control device.

**Centrifugal Inertial Force**

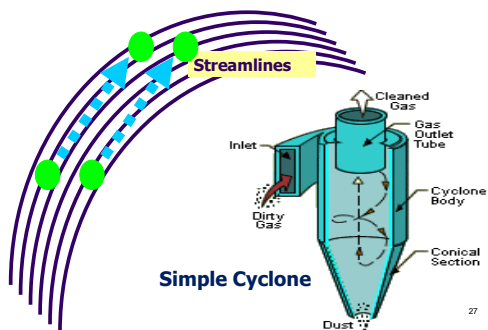

27

**Top View of Spinning Gas in a Cyclone**

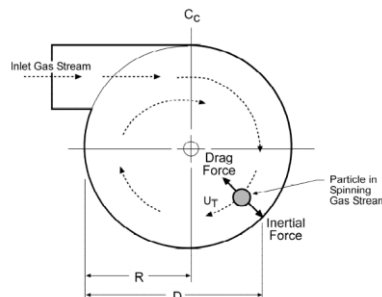

Inertial force can be an effective collection mechanism when a particulate-laden gas stream is made to flow in a circular manner within a cylinder, as shown above. Inertial force that is applied in a spinning gas stream is often termed *centrifugal force*.

28

**Forces on a Particle**

• Centrifugal force  $F_C = \frac{\pi d_p^3 \rho_p u_T^2}{6 R}$

• Drag force  $F_D = \frac{3 \pi \mu_g v_p d_p}{C_c}$

$u_T$  = tangential velocity of the gas (cm/sec)  
 $R$  = cylinder radius (cm)

The movement of particles due to inertial force in a spinning gas stream is estimated using the same procedure described for terminal settling velocity due to gravitational force. Accordingly:  $F_C = F_D$  Next, by substitution solve for  $V_p$

**Particle Radial Velocity ( $V_p$ )**

$$V_p = \frac{C_c d_p^2 \rho_p u_T^2}{18 \mu_g R}$$

This equation illustrates that the velocity of the particle moving across the gas stream lines in the cyclone and toward the cyclone wall is proportional to the square of the particle size. This means that cyclones will be substantially more effective for large particles than for small particles.

$V_p = V_c$  = radial particle velocity (cm/sec)  
 $C_c$  = Cunningham slip correction factor (dimensionless)  
 $\rho_p$  = particle density (g/cm<sup>3</sup>)  
 $\mu_g$  = gas viscosity (g/(cm·sec))  
 $d_p$  = physical particle diameter (cm)  
 $u_T$  = tangential velocity of the gas (cm/sec)  
 $R$  = cylinder radius (cm)

30

### Inertial Impaction Mechanism

#### Wet Scrubber

#### Baghouse

Impaction, the primary collection mechanism in wet scrubbers, is much more efficient for large particles  $\geq 0.5 \mu\text{m}$

### Inertial Impaction

The inertia of a particle in motion in a gas stream can cause it to strike slow-moving or stationary obstacles in its path. **As the gas stream deflects to flow around the obstacle, the particle, because of its inertia, is displaced across the gas streamlines and toward the direction of the target.** If it has sufficient inertia, the particle contacts the obstacle and is captured.

### Inertial Impaction Parameter

$$\Psi_I = \frac{C_c d_p^2 v_p \rho_p}{18 \mu_g D_c}$$

Impaction can be evaluated using the same procedures used to evaluate gravitational settling and centrifugal force. This equation is for laminar flow.

Where

- $\Psi_I$  = inertial impaction parameter (dimensionless)
- $C_c$  = Cunningham slip correction factor (dimensionless)
- $d_p$  = physical particle diameter (cm)
- $v_p$  = difference in velocity between the particle and the target (cm/sec)
- $D_c$  = diameter of collection target (cm)
- $\rho_p$  = particle density (g/cm<sup>3</sup>)
- $\mu_g$  = gas viscosity (g/(cm. sec))

As the value of this parameter increases, particles have a greater tendency to move radially toward the collection target. As the value of the parameter approaches zero, the particles have a tendency to remain on the gas streamlines and pass around the target.

### Single-Droplet Collection Efficiency

$$\eta_I = \left( \frac{\Psi_I}{\Psi_I + 0.35} \right)^2$$

$$\Psi_I = \frac{C_c d_p^2 \rho_p V_r}{18 \mu_g d_d}$$

where:

- $\Psi_I$  = inertial impaction parameter (dimensionless)
- $C_c$  = Cunningham slip correction factor (dimensionless)
- $d_p$  = physical particle diameter (cm)
- $\rho_p$  = particle density (gm/cm<sup>3</sup>)
- $V_r$  = relative velocity between particle and droplet (cm/sec)
- $d_d$  = droplet diameter (cm)
- $\mu_g$  = gas viscosity (gm/cm sec)

### Cyclone Efficiency using Leith Technique

$$\eta = 1 - e^{-2(C\Psi)^{\frac{1}{n+2}}}$$

where

- $\eta_i$  = efficiency for particle diameter i (dimensionless)
- $C$  = cyclone dimension factor (dimensionless)
- $\Psi$  = cyclone inertial impaction parameter (dimensionless)
- $n$  = vortex exponent (dimensionless)

### Brownian Motion

Very small particles (0.2  $\mu\text{m}$  to 0.002  $\mu\text{m}$ ) deflect slightly when they are struck by gas molecules. The deflection is caused by the transfer of kinetic energy from the rapidly moving gas molecule to the small particle.

### Diffusional Collection Parameter

As the value of this parameter increases, particles have an increasing tendency to be collected by Brownian motion.

$$\psi_D = \frac{C_c k T}{3\pi\mu_g d_p D_c v_p}$$

Where

- $k$  = Boltzmann constant ( $g \cdot cm^2/sec^2 \cdot K$ )
- $T$  = absolute temperature (K)
- $C_c$  = Cunningham slip correction factor (dimensionless)
- $\mu_g$  = gas viscosity ( $g/cm \cdot sec$ )
- $d_p$  = physical particle diameter (cm)
- $D_c$  = diameter of collection plate
- $v_p$  = relative velocity between particle and collection target (cm/sec)

The diffusional collection parameter indicates that collection efficiency by diffusion will be greatest when the particle size is small, the relative velocity is low and the collection target is small

### Electrostatic Attraction

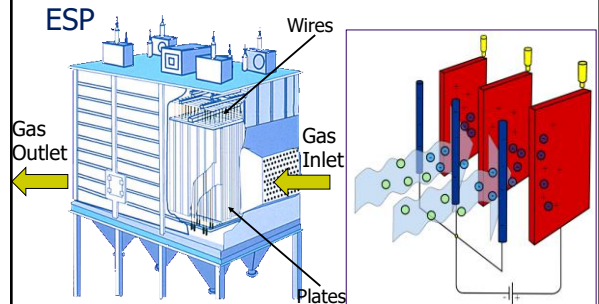

The electric field near the wire causes ionization of the gas resulting in a "corona." As these ions migrate toward the collection electrode they collide and become attached to the particles suspended in the gas stream. The particles then become charged and migrate toward the collection electrode.

### Charging Mechanisms: There are two particle charging mechanisms to collect particulate matter.

#### Field Charges

- Occurs when particles placed in a strong electrical field with a high concentration of unipolar ions. The particles capture negative charged gas ions as the ions move toward the grounded collection plate.
- For large particles  $>0.5\mu m$

#### Diffusion Charges

- Depends on the random motion of the gas ions to charge particles (not the electric field). Particles that acquire an electrical charge will move along the electrical field lines to an area of lower field strength (collection plate).
- For small particles  $<0.4\mu m$

Both charge mechanisms operate at the same time on all particles.

### Charging Mechanisms

#### • Field charging

$$n_f = \left( \frac{3\varepsilon}{\varepsilon + 2} \right) \left( \frac{E d_p^2}{4e} \right)$$

Where

- $n_f$  = number of charges deposited by field charging
- $d_p$  = particle diameter (cm)
- $\varepsilon$  = dielectric constant of the particle (dimensionless)
- $e$  = charge of an electron ( $e = 4.8 \times 10^{-10}$  statcoulomb)
- $E$  = electrical field strength (statvolts/cm)

40

### Charging Mechanisms

#### • Diffusion charging

$$n_d = \frac{d_p k T}{2e^2} \ln \left( 1 + \frac{\pi d_p c_i e^2 N_i t}{2k T} \right)$$

Where

- $n_d$  = number of charges deposited by diffusion charging
- $d_p$  = particle diameter (cm)
- $k$  = Boltzmann constant ( $k = 1.4 \times 10^{-16} g \cdot cm^2/sec^2 \cdot K$ )
- $T$  = absolute temperature (K)
- $c_i$  = ion velocity ( $c_i = 2.4 \times 10^4$  cm/sec)
- $e$  = charge of an electron ( $e = 4.8 \times 10^{-10}$  statcoulomb)
- $t$  = time (sec)
- $N_i$  = ion concentration (number/cm<sup>3</sup>)

41

### Forces on a Particle

#### • Electrostatic force (charge on the particle)

$$F_E = n e E$$

- Where  $F_E$  = electrostatic force (dyne)
- $n$  = number of charges ( $n_f + n_d$ )
- $e$  = charge of an electron ( $e = 4.8 \times 10^{-10}$  statcoulomb)
- $E$  = electric field strength (statvolt/cm)

- Drag force 
$$F_D = \frac{3\pi\mu_g v_p d_p}{C_c}$$

42

### Particle Migration Velocity ( $V_p$ )

$$F_E = F_D$$

$$V_p = \omega = \frac{neEC_c}{3\pi\mu_g d_p}$$

This particle velocity is called the *migration velocity* or *drift velocity*. This relationship applies to particles in the laminar region. When  $Re_p > 1.0$ , a more complicated procedure is required. 43

### Example 4-3

Determine the migration velocity of a 2  $\mu\text{m}$  unit-density particle carrying 800 units of charge in an electric field of 2kV/cm. Assume that the gas temperature is 20°C:

$$v_p = \omega = \frac{neEC_c}{3\pi\mu_g d_p}$$

#### Solution:

To solve this problem, the following relationships are used:

- 300 volts = 1 statvolt
- 1 statvolt = 1 statcoulomb/cm
- 1 dyne = 1 statcoulomb<sup>2</sup>/cm<sup>2</sup> = 1 g.cm/sec<sup>2</sup>
- $C_c = 1.09$  (as calculated in Example 4-2)
- $e =$  charge of an electron ( $e = 4.8 \times 10^{-10}$ ) statcoulomb
- (the viscosity of air at 20°C is  $1.80 \times 10^{-4}$  g/cm(sec)) 44

The electric field in centimeter-gram-second units is:

$$E = 2 \frac{\text{kV}}{\text{cm}} = 2,000 \frac{\text{V}}{\text{cm}} \left( \frac{\text{statvolt}}{300 \text{ volts}} \right) = 6.67 \frac{\text{statvolts}}{\text{cm}} = 6.67 \frac{\text{statcoulombs}}{\text{cm}^2}$$

$$\omega = \frac{neEC_c}{3\pi\mu_g d_p} = \frac{(800)(4.8 \times 10^{-10} \text{ statcoulombs}) \left( 6.67 \frac{\text{statcoulombs}}{\text{cm}^2} \right) (1.09)}{3\pi \left( 1.8 \times 10^{-4} \frac{\text{g}}{\text{cm sec}} \right) (2 \times 10^{-4} \text{cm})}$$

$$= 8.23 \text{ cm/sec}$$
45

Table 4-2. Equations used to estimate collection efficiency and collection area

Calculation	Deutsch-Anderson	Matts-Ohnfeldt
Collection efficiency	$\eta = 1 - e^{-w(A/Q)}$	$\eta = 1 - e^{-w_k(A/Q)^k}$
Collection area (to meet a required efficiency)	$A = \frac{Q}{w} [\ln(1 - \eta)]$	$A = \left[ -\left( \frac{Q}{w_k} \right)^k \ln(1 - \eta) \right]^{1/k}$
Where:	<ul style="list-style-type: none"> <li><math>\eta</math> = collection efficiency</li> <li><math>A</math> = collection area</li> <li><math>w</math> = migration velocity</li> <li><math>Q</math> = gas flow rate</li> <li><math>\ln</math> = natural logarithm</li> </ul>	<ul style="list-style-type: none"> <li><math>\eta</math> = collection efficiency</li> <li><math>A</math> = collection area</li> <li><math>w_k</math> = average migration velocity</li> <li><math>k</math> = constant (usually 0.5)</li> <li><math>\ln</math> = natural logarithm</li> </ul>

An empirically derived migration velocity (from a variety of similar units) is used to calculate the necessary collection plate area of a new  $w_k$  installation.

### Field & Diffusion Charging Effects on Particle Size & Collection Efficiency

- The combined effect of contact and diffusion charging creates a particle size-collection efficiency relationship similar to this Figure.
- There are very high collection efficiencies above 1.0  $\mu\text{m}$  due to the increasing effectiveness of field (contact) charging for large particles.
- Increased diffusion charging causes collection efficiency to increase for particles smaller than 0.1  $\mu\text{m}$ .
- There is a difficult-to-control range between 0.1 to 1.0  $\mu\text{m}$  due to the size dependent limitations of both of these charging mechanisms.

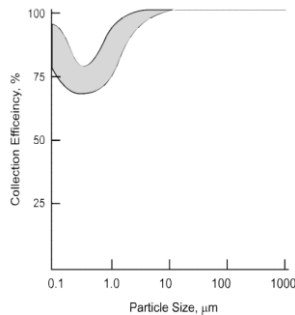

### Collection Efficiency as a Function of Particle Size

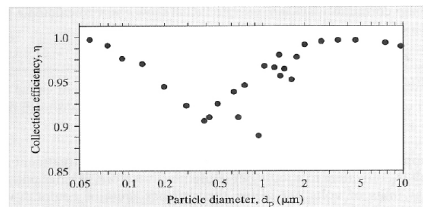
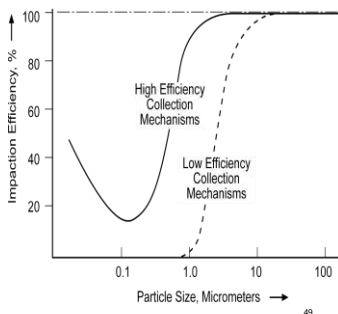

Figure 7.C.4 Measured collection efficiency as a function of particle size for an electrostatic precipitator installed on a pulverized coal boiler. (Reprinted with permission of the Air & Waste Management Association from J.D. McCain et al. [1975].)

Larger particles are removed more efficiently because they acquire a greater electric charge, whereas smaller particles, too, are removed more efficiently because they are subjected to less drag and thus drift more easily, leaving intermediate particles as those that are less efficiently collected. Nonetheless, efficiency easily exceeds 90% for most particles. 48

### Size-Efficiency Relationships

For particles less than 10  $\mu\text{m}$ , the limits of inertial forces and electrostatic forces begin to become apparent, and the efficiency drops. Efficiency of these collection mechanisms reaches low levels between 1  $\mu\text{m}$  and 0.1  $\mu\text{m}$ , depending on such factors as gas velocities (inertial forces) and electrical field strengths (electrostatic attraction). Below 0.3  $\mu\text{m}$ , Brownian motion begins to become effective.



**Phoretic Forces:** are two relatively weak forces that can affect collection of sub-micrometer particles

- **Thermophoresis** is particle movement caused by temperature differences on opposite sides of the particle.
  - The gas molecule kinetic energies on the hot side of the particle are higher than they are on the cold side. Therefore, collisions with the particle on the hot side transfer more energy than molecular collisions on the cold side. Accordingly, the particle is deflected toward the cold area.
- **Diffusiophoresis** is particle movement caused by concentration differences on opposite sides of the particle.
  - When there is a strong difference in the concentration of molecules on opposite sides of the particle, there is a difference in the number of molecular collisions. The particle moves toward the area of lower concentration.





**Chapter 5**

---



**Settling Chambers**

1

## Settling Chambers

**Collection Mechanism:**

- *Gravitational settling*
- Generally limited to the removal of particles larger than about 40-60 μm diameter

2

## Settling Chambers

**Three Basic Types of Settling Chambers:**

- Simple expansion chamber,
- Multiple-tray settling chamber, &
- Momentum separator

3

### Simple Settling Chamber

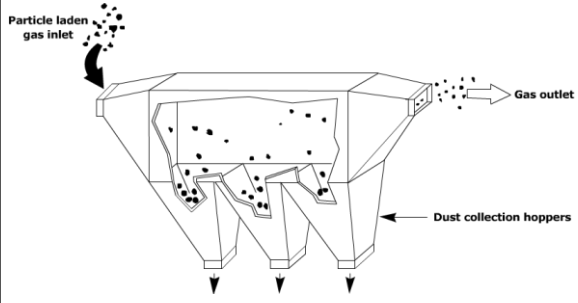

Particles in the gas stream are subjected to the force of gravity and settle into the dust collection hoppers

4

### Multi-Tray Settling Chamber

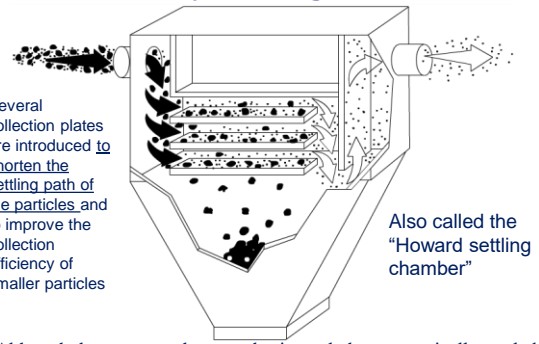

Several collection plates are introduced to shorten the settling path of the particles, and to improve the collection efficiency of smaller particles

Also called the "Howard settling chamber"

Although the trays are shown as horizontal, they are typically angled vertically upward to provide for gravity cleaning.

5

### Momentum Separators

Cause the gas to change directions and add a downward inertial force to supplement the gravitational force.

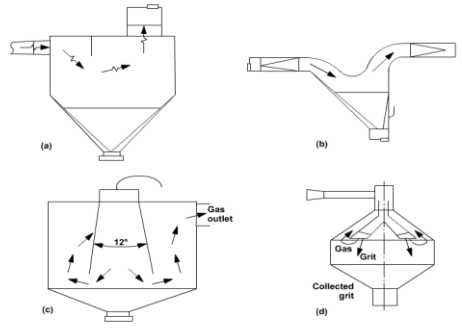

6

### Performance Evaluation

Suppose a particle enters the chamber at a height,  $h_p$ . The particle must fall this distance before it travels the length of the chamber, if the particle is to be collected

7

### Collection Efficiency (for one sized particle)

$$\eta_i = 1 - e^{-X}$$

$$X = \frac{t_r}{t_s}$$

where  
 $t_r$  = chamber residence time  
 $t_s$  = particle settling time

8

$$t_r = \frac{L}{v_g}$$

$$v_g = \frac{Q}{WH}$$

$$t_r = \frac{LWH}{Q}$$

$$t_s = \frac{H}{v_t}$$

9

### Collection Efficiency

$$\eta_i = 1 - e^{-\left(\frac{v_{ti}LWN_c}{Q}\right)}$$

$$X = \frac{t_r}{t_s}$$

where  
 $v_t$  = particle terminal settling velocity (ft/sec)  
 $L$  = chamber length (ft)  
 $Q$  = gas flow rate (ft<sup>3</sup>/sec)  
 $W$  = chamber width (ft)  
 $N_c$  = number of passages through chamber

10

### Terminal Settling Velocity

Laminar Regime (also,  $C_c$  is assumed to be one)

$$v_{ti} = \frac{g C_c \rho_p d_{pi}^2}{18 \mu_g}$$

where  
 $v_t$  = terminal settling velocity (ft/sec)  
 $g$  = acceleration of particle due to gravity (32.17 ft/sec<sup>2</sup>)  
 $\rho_p$  = particle density (lb<sub>m</sub>/ft<sup>3</sup>)  
 $\mu_g$  = gas viscosity (lb<sub>m</sub>/(ft-sec))  
 $d_p$  = physical particle diameter (ft)

11

### Collection Efficiency

Laminar Regime

$$\eta_i = 1 - e^{-\left(\frac{g \rho_p L W N_c}{18 \mu_g Q}\right) d_{pi}^2}$$

$g$  = acceleration of particle due to gravity (32.17 ft/sec<sup>2</sup>)  
 $\rho_p$  = particle density (lb<sub>m</sub>/ft<sup>3</sup>)  
 $\mu_g$  = gas viscosity (lb<sub>m</sub>/(ft-sec))  
 $d_p$  = physical particle diameter (ft)  
 $Q$  = gas flow rate (ft<sup>3</sup>/sec)  
 $W$  = chamber width (ft)  
 $L$  = chamber length (ft)  
 $N_c$ : For a simple settling chamber,  $N_c$  is one. For a multi-tray settling chamber,  $N_c$  is the number of trays plus one.

12

**Example 5-1**

Estimate the collection efficiency of a 75 μm diameter particle in a simple settling chamber 10 ft wide by 10 ft high by 30 ft long when the gas velocity through the chamber is 5 ft/sec.

Assume a particle density of 120 lb<sub>m</sub>/ft<sup>3</sup> and gas stream conditions of 68°F and 1 atm.

At 68 °F, viscosity of air 1.21 x 10<sup>-5</sup> lb<sub>m</sub>/ft-sec

**Solution**

$$\eta_i = 1 - e^{-\left(\frac{g\rho_p LWN_c}{18\mu_g Q}\right)d_p^2}$$

Convert particle size to feet:

$$d_p = 75\mu\text{m} \left(\frac{\text{ft}}{0.3048 \times 10^6 \mu\text{m}}\right) = 2.46 \times 10^{-4} \text{ ft}$$

13

**Example 5-1 continued...**

Calculate volumetric flow rate:

$$Q = v_g WH = \left(5 \frac{\text{ft}}{\text{sec}}\right)(10\text{ft})(10\text{ft}) = 500 \frac{\text{ft}^3}{\text{sec}}$$

Calculate collection efficiency:

$$\eta = 1 - e^{-\left(\frac{g\rho_p LWN_c}{18\mu_g Q}\right)d_p^2} = 1 - e^{-\left[\frac{\left(32.17 \frac{\text{ft}}{\text{sec}^2}\right)\left(120 \frac{\text{lb}_m}{\text{ft}^3}\right)(30\text{ft})(10\text{ft})(1)}{18\left(1.21 \times 10^{-5} \frac{\text{lb}_m}{\text{ft}\cdot\text{sec}}\right)\left(500 \frac{\text{ft}^3}{\text{sec}}\right)}\right](2.46 \times 10^{-4} \text{ft})^2} = 0.475 = 47.5\%$$

14

**Chamber Velocity**

In settling chamber designs, the velocity at which the gas moves through the chamber is called the **throughput velocity**. The velocity at which settled particles become re-entrained is called the **pickup velocity**. In order to avoid re-entrainment of collected dust, the throughput velocity must not exceed the pickup velocity. If no data available, the pickup velocity is assumed to be 10 ft/sec.

Table 5-1. Pickup Velocities of Various Materials

Material	Density (g/cm <sup>3</sup> )	Median Size (μm)	Pickup Velocity (ft/sec)
Aluminum chips	2.72	335	14.2
Asbestos	2.20	261	17.0
Nonferrous foundry dust	3.02	117	18.8
Lead oxide	8.26	15	25.0
Limestone	2.78	71	21.0
Starch	1.27	64	5.8
Steel shot	6.85	96	15.2
Wood chips	1.18	1,370	13.0
Sawdust	---	1,400	22.3

15

**Advantages and Disadvantages**

Advantages:

- Low Capital Cost
- Very Low Energy Cost
- No Moving Parts
- Few Maintenance Requirements
- Low Operating Costs
- Excellent Reliability
- Low Pressure Drop
- Device Not Subject to Abrasion
- Provides Incidental Cooling of Gas Stream
- Dry Collection and Disposal

Disadvantages:

- Relatively Low PM Collection Efficiencies
- Unable to Handle Sticky or Tacky Materials
- Large Physical Size
- Trays in Multiple-Tray Settling Chamber may Warp

16

**Review Questions**

Estimate the collection efficiency of a 50 μm diameter particle in a simple settling chamber 5 meters wide by 2 meters high by 10 meters long when the gas velocity is 0.3 m/sec.

Assume a particle density of 4.6 g/cm<sup>3</sup> and gas stream conditions of 20°C and 1 atm.

(the density of air at 20°C is 1.20 x 10<sup>-3</sup> g/cm<sup>3</sup> and the viscosity is 1.80 x 10<sup>-4</sup> g/cm(sec))

17

**Review Solutions**

Calculate the volumetric flow rate:

$$Q = v_g WH = \left(0.3 \frac{\text{m}}{\text{sec}}\right)(5\text{m})(2\text{m}) = 3.0 \frac{\text{m}^3}{\text{sec}} = 3.0 \times 10^6 \frac{\text{cm}^3}{\text{sec}}$$

Calculate collection efficiency:

$$\eta = 1 - e^{-\left(\frac{g\rho_p LWN_c}{18\mu_g Q}\right)d_p^2} = 1 - e^{-\left[\frac{\left(980 \frac{\text{cm}}{\text{sec}^2}\right)\left(4.6 \frac{\text{g}}{\text{cm}^3}\right)(1,000\text{cm})(500\text{cm})(1)}{18\left(1.80 \times 10^{-4} \frac{\text{g}}{\text{cm}\cdot\text{sec}}\right)\left(3.0 \times 10^6 \frac{\text{cm}^3}{\text{sec}}\right)}\right](50 \times 10^{-4} \text{cm})^2} = 0.997 = 99.7\%$$

18



**Chapter 6**

**Cyclones**

6 - 1

**Operating Principles**

- Collection mechanisms
- Factors affecting performance

6 - 2

**Collection Mechanisms**

- Centrifugal inertial force
- Gravitational settling

6 - 3

**Medium Efficiency Cyclone**



6 - 4

**High Volume Cyclone**



6 - 5

**Multiple (6) Cyclones Operating in Parallel**



6 - 6

Cyclones In Parellel



6-7

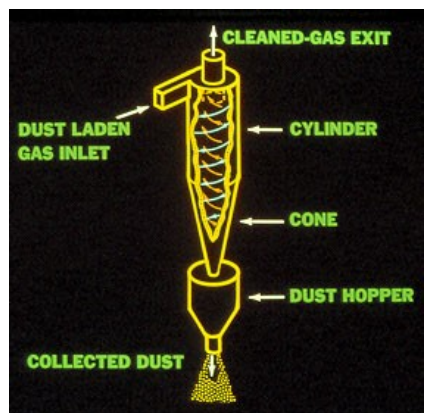

6-8

Cyclones Staged for Installation in a Fluid Catalytic Cracker (FCC) Regenerator



6-9

Model of Cyclones in a FCC Unit

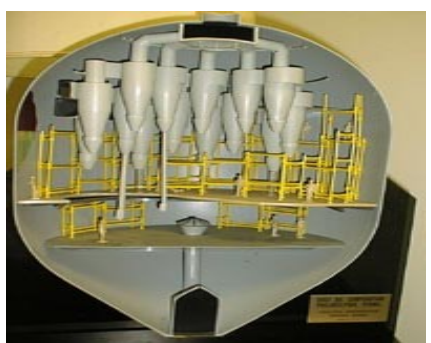

6-10

Effect of temperature on cyclone efficiency

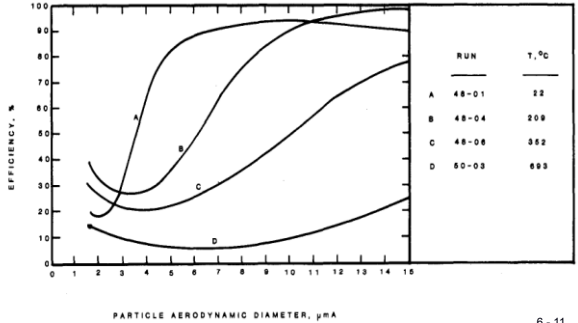

6-11

Particle Collection in Cyclones at High Temperature and Pressure ES&T Vol.15 No. 4 April 1981

Effect of pressure on cyclone efficiency

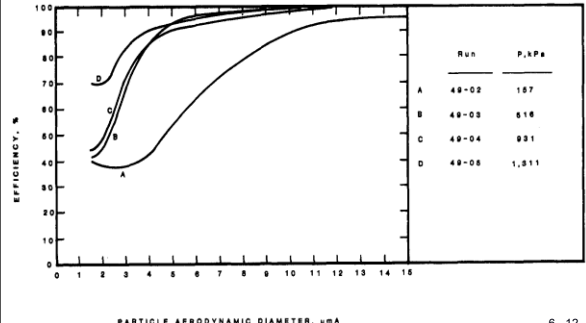

6-12

Particle Collection in Cyclones at High Temperature and Pressure ES&T Vol.15 No. 4 April 1981

Factors Affecting Performance

- Particle diameter:  $E = f(d^2)$
- Gas flow rate:  $E = f(Q^2)$
- Cyclone diameter
- Residence time

6 - 13

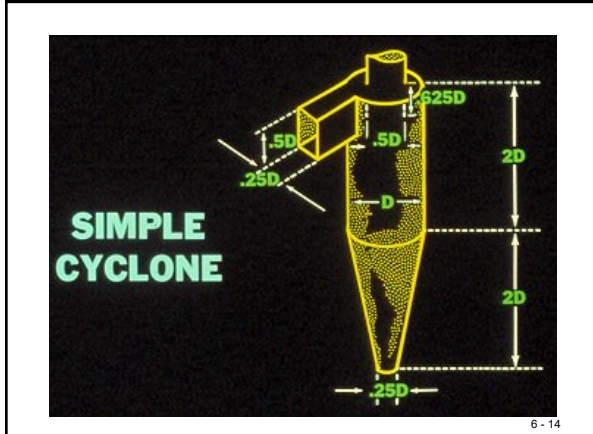

6 - 14

Fractional Efficiency vs: Particle size

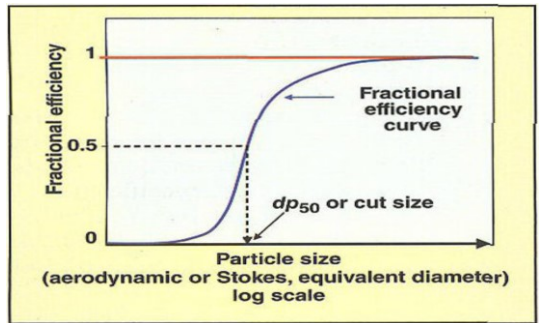

Chemical Engineering Magazine May 2011 [www.CHE.com](http://www.CHE.com)  
 Harnessing the Power of a Cyclone

6 - 15

Efficiency Curves for Defined Particle Size Diameters

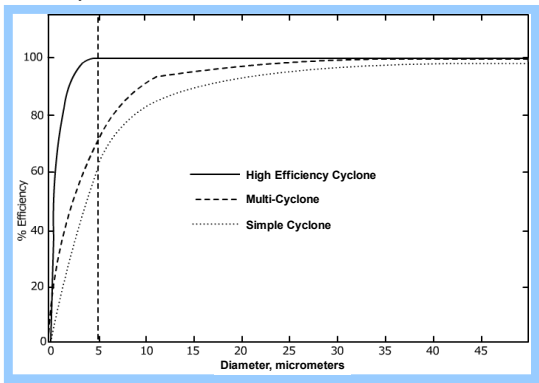

6 - 16

Cyclone and Control Efficiency

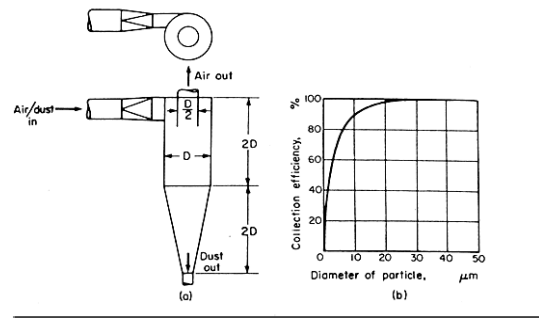

6 - 17

Cyclone Dimensions

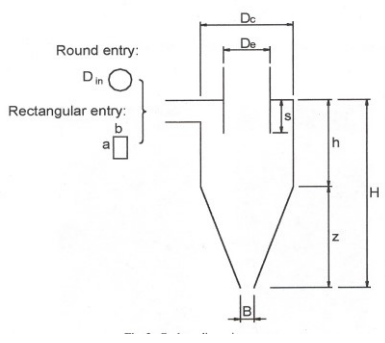

**Dimensions for the Design of Standard Cyclones**

Family Use:	Lapple General purpose	Swift General purpose	Stairmand High efficiency	Swift High efficiency	Stairmand High flow rate <sup>a</sup>	Swift High flow rate <sup>a</sup>
$Q/D_c^2$ (m <sup>3</sup> /h)	6,860	6,680	5,500	4,940	16,500	12,500
$a/D_c$	0.5	0.5	0.5	0.44	0.75	0.8
$b/D_c$	0.25	0.25	0.2	0.21	0.375	0.35
$H/D_c$	4.0	3.75	4.0	3.9	4.0	3.7
$h/D_c$	2.0	1.75	1.5	1.4	1.5	1.7
$D/D_c$	0.5	0.5	0.5	0.4	0.75	0.75
$B/D_c$	0.25	0.4	0.375	0.4	0.375	0.4
$S/D_c$	0.625	0.6	0.5	0.5	0.875	0.85
$\Delta H$	8.0	7.6	6.4	9.2	7.2	7.0

<sup>a</sup>Half-scroll entry.  
Source: ref. 2.

**Characteristics of Common Cyclones**

Cyclone Dimension	Cyclone Type					
	High Efficiency		Conventional		High Throughput	
	(I)	(II)	(III)	(IV)	(V)	(VI)
Body Diameter, $D/D$	1.0	1.0	1.0	1.0	1.0	1.0
Inlet Height, $a/D$	0.5	0.44	0.5	0.5	0.75	0.8
Inlet Width, $b/D$	0.2	0.21	0.25	0.25	0.375	0.35
Gas Exit Diameter, $D_e/D$	0.5	0.4	0.5	0.5	0.75	0.75
Vortex Finder Length, $S/D$	0.5	0.5	0.625	0.6	0.875	0.85
Body Length, $h/D$	1.5	1.4	2.0	1.75	1.5	1.7
Cone Length, $L_c/D$	2.5	2.5	2.0	2.0	2.5	2.0
Dust Outlet Diameter, $B/D$	0.375	0.4	0.25	0.4	0.375	0.4

**Design configurations for tangential-entry cyclone** Table I

Nomenclature	High-efficiency		General-purpose		
	Stairmand [12]	Swift [15]	Lapple [4]	Swift [15]	Peterson & Whitby [8]
$D_c$ body dia.	1.0	1.0	1.0	1.0	1.0
$a$ inlet height	0.5	0.44	0.5	0.5	0.583
$b$ inlet width	0.2	0.21	0.25	0.25	0.208
$S$ outlet length	0.5	0.5	0.625	0.6	0.583
$D_p$ outlet dia.	0.5	0.4	0.5	0.5	0.5
$h$ cylinder height	1.5	1.4	2.0	1.75	1.333
$H$ overall height	4.0	3.9	4.0	3.75	3.17
$B$ dust outlet dia.	0.375	0.4	0.25	0.4	0.5
$j$ natural length	2.48	2.04	2.30	2.30	1.8
$G$ $8 K_c K_b^2 K_a^2$	551.3	699.2	402.9	381.8	324.8
$N_H$ $16 ab/D_c^2$	6.40	9.24	8.0	8.0	7.76
$G/N_H$	86.14	75.67	50.36	47.7	41.86

CHEMICAL ENGINEERING NOVEMBER 7, 1977

### Cyclone Systems

- Large diameter cyclones
- Small diameter multi-cyclones

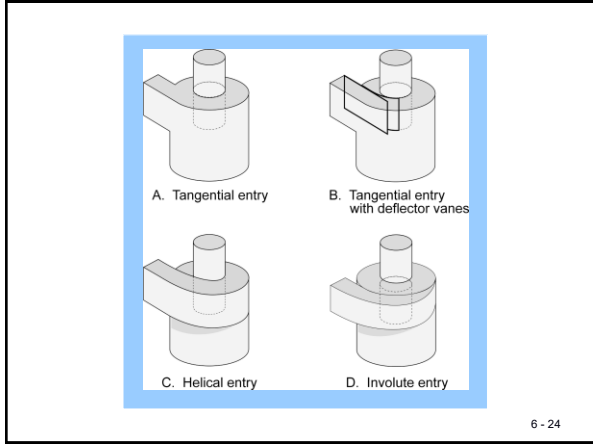
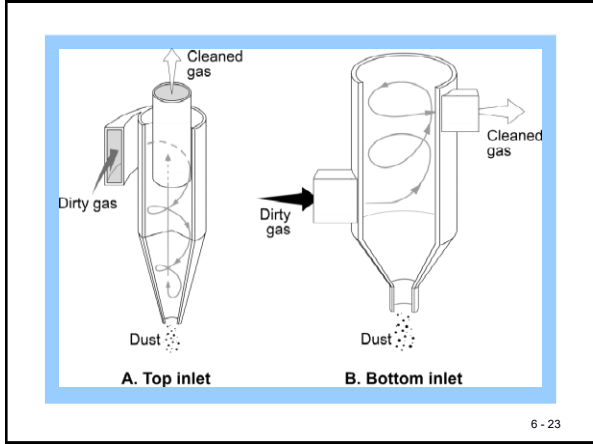



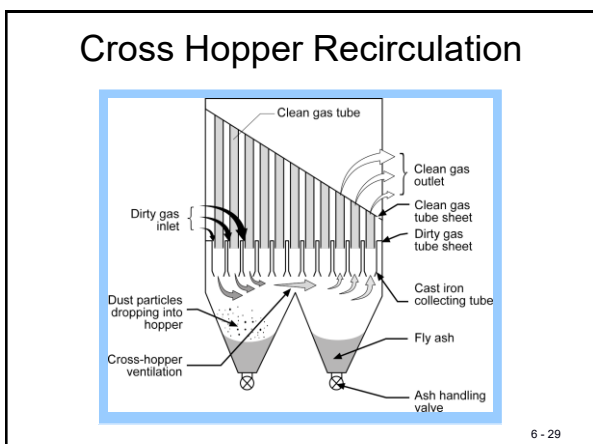
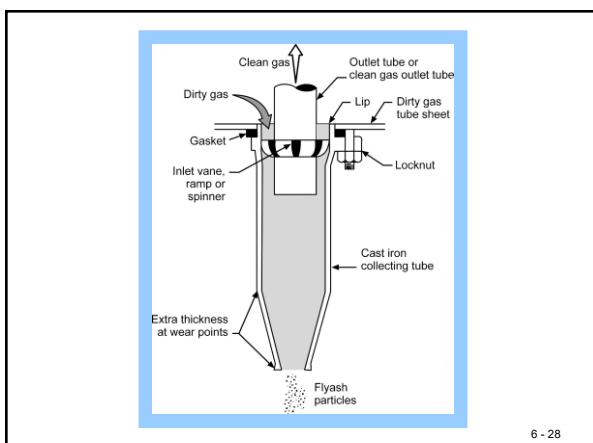
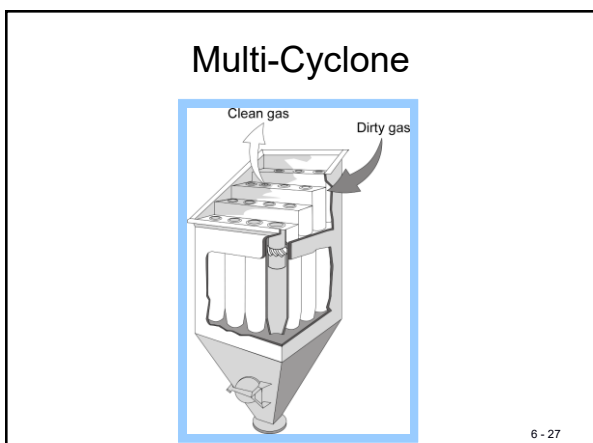
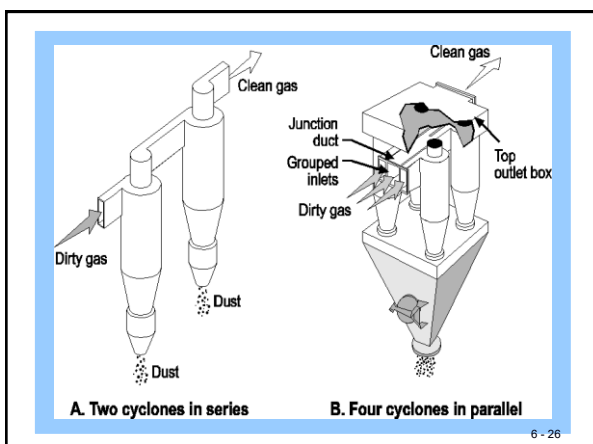
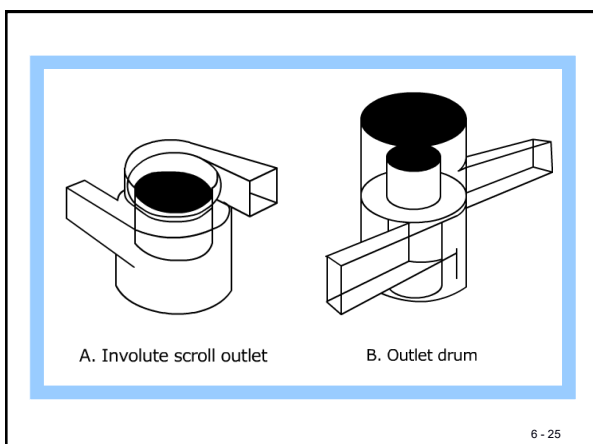

- ### Performance Evaluation
- Collection efficiency
    - Lapple technique
    - Leith technique
  - Pressure drop
  - Hopper design
  - Instrumentation
- 6 - 30

Collection Efficiency

Lapple Technique

$$[d_p]_{cut} = \sqrt{\frac{9\mu_g B_c}{2\pi n_t v_i \rho_p}}$$

- $[d_p]_{cut}$  = cut diameter (ft)
- $\mu_g$  = gas viscosity (lb<sub>m</sub>/ft·sec)
- $v_i$  = inlet gas velocity (ft/sec)
- $\rho_p$  = particle density (lb<sub>m</sub>/ft<sup>3</sup>)
- $\rho_g$  = gas density (lb<sub>m</sub>/ft<sup>3</sup>)
- $B_c$  = cyclone inlet width (ft)
- $n_t$  = number of turns

6 - 31

$$n_t = \frac{v_i t}{\pi D}$$

$$t = \frac{V_{cyclone} - V_{outlet\ core}}{Q}$$

- $v_i$  = inlet gas velocity (ft/sec)
- $t$  = residence time (sec)
- $D$  = cyclone diameter (ft)
- $V_{cyclone}$  = total volume of cyclone (ft<sup>3</sup>)
- $V_{outlet\ core}$  = volume of outlet core (ft<sup>3</sup>)
- $Q$  = volumetric flow rate (ft<sup>3</sup>/sec)

6 - 32

Lapple Efficiency Curve

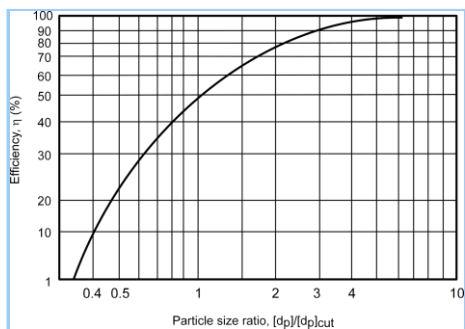

6 - 33

Example 6-1

6 - 34

Example 6-1

A large diameter cyclone is being used for the removal of grain dust in the range of 8 to 100 μm diameter. What are collection efficiencies over this range if the cyclone has an inlet width of 1 ft, an inlet gas velocity of 50 ft/sec, and an operating temperature of 68°F? Assume  $n_t = 1$  and a particle density of 80 lb<sub>m</sub>/ft<sup>3</sup>.

Solution:

$$[d_p]_{cut} = \sqrt{\frac{9\mu_g B_c}{2\pi n_t v_i \rho_p}} = \sqrt{\frac{9 \left( 1.21 \times 10^{-3} \frac{\text{lb}_m}{\text{ft} \cdot \text{sec}} \right) (1 \text{ ft})}{2\pi (1) \left( 50 \frac{\text{ft}}{\text{sec}} \right) \left( 80 \frac{\text{lb}_m}{\text{ft}^3} \right)}} = 6.58 \times 10^{-3} \text{ ft} = 20 \mu\text{m}$$

Estimate efficiency of 8, 12, 20, 30, 50 and 100 μm diameter particles:

Example 6-1 Efficiency Estimates		
$[d_p]_i$ (μm)	$[d_p]_i/[d_p]_{cut}$	$\eta_i$ (%)
8	0.40	9
12	0.60	28
20	1.00	50
30	1.50	65
50	2.50	85
100	5.00	98

6 - 35

Collection Efficiency

Leith Technique

$$\eta = 1 - e^{-2(C\Psi)^{\frac{1}{2n+2}}}$$

Where:

- $\eta_i$  = efficiency for particle diameter  $i$  (dimensionless)
- $C$  = cyclone dimension factor (dimensionless)
- $\Psi$  = cyclone inertial impaction parameter (dimensionless)
- $n$  = vortex exponent (dimensionless)

6 - 36

**Leith and Licht Equation Solution**

1. Calculate n from Equation 6-5, using Equation 6-6 to adjust the value from ambient to elevated temperature, if necessary:

$$n = \frac{(12D)^{0.14}}{2.5} \quad (6-5)$$

where  
D = cyclone diameter (ft)

$$\frac{1-n_1}{1-n_2} = \left(\frac{T_1}{T_2}\right) \quad (6-6)$$

where  
n<sub>1</sub> = vortex index at ambient temperature (dimensionless)  
n<sub>2</sub> = vortex index at elevated temperature (dimensionless)  
T<sub>1</sub> = ambient absolute temperature (°R)  
T<sub>2</sub> = elevated absolute temperature (°R)

6 - 37

**Leith and Licht Equation Solution**

2. Calculate the vortex natural length, l, and compare this with the value of the dimension (H - S):

$$l = 2.3D_c \left(\frac{D_c^2}{ab}\right)^{1/3} \quad (6-7)$$

where  
l = vortex natural length (ft)  
D<sub>c</sub> = cyclone outlet diameter (ft)  
D = cyclone diameter (ft)  
a = cyclone inlet height (ft)  
b = cyclone inlet width (ft)  
H-S = overall cyclone height - outlet pipe length

A. If l < (H - S), calculate V<sub>nl</sub>:

$$V_{nl} = \frac{\pi D_c^2}{4}(h-S) + \frac{\pi D_c^2}{4} \left( \frac{1+S-h}{3} \right) \left( 1.0 + \frac{d}{D} + \frac{d^2}{D^2} \right) - \frac{\pi D_c^2 l}{4} \quad (6-8)$$

$$d = D - (D - B) \left( \frac{1+S-h}{H-h} \right) \quad (6-8a)$$

6 - 38

**Leith and Licht Equation Solution**

where:

V<sub>nl</sub> = volume of cyclone at natural length (ft<sup>3</sup>)  
D = cyclone diameter (ft)  
h = height of upper cylindrical body of cyclone (ft)  
S = outlet pipe length (ft)  
l = vortex natural length (ft)  
D<sub>e</sub> = outlet pipe diameter (ft)  
H = overall cyclone height (ft)

B. If l > (H - S), calculate V<sub>H</sub>:

$$V_H = \frac{\pi D^2}{4}(h-S) + \frac{\pi D^2}{4} \left( \frac{H-h}{3} \right) \left( 1.0 + \frac{B}{D} + \frac{B^2}{D^2} \right) - \frac{\pi D^2}{4}(H-S) \quad (6-9)$$

where  
V<sub>H</sub> = volume of cyclone below end of exit pipe (ft<sup>3</sup>)  
B = dust outlet diameter (ft)

19

**Leith and Licht Equation Solution**

3. Calculate K<sub>c</sub> using either V<sub>nl</sub> or V<sub>H</sub>:

$$K_c = \frac{V_s + \frac{V_{nl}}{2}}{D^3} \text{ or } K_c = \frac{V_s + \frac{V_H}{2}}{D^3} \quad (6-10)$$

$$V_s = \frac{\pi \left( S - \frac{a}{2} \right) (D^2 - D_e^2)}{4} \quad (6-10a)$$

where  
K<sub>c</sub> = cyclone volume constant (dimensionless)  
V<sub>s</sub> = annular shaped volume above exit duct to midlevel of entrance duct (ft<sup>3</sup>)  
V<sub>nl</sub> = volume of cyclone at natural length (ft<sup>3</sup>)  
V<sub>H</sub> = volume of cyclone below end of exit pipe (ft<sup>3</sup>)  
S = outlet pipe length (ft)  
D = cyclone diameter (ft)  
D<sub>e</sub> = outlet pipe diameter (ft)  
a = cyclone inlet height (ft)

6 - 40

**Leith and Licht Equation Solution**

4. Calculate the cyclone dimension factor:

$$C = \frac{8K_c}{K_a K_b} \quad (6-11)$$

where  
C = cyclone dimension factor (dimensionless)  
K<sub>a</sub> = cyclone inlet height divided by the cyclone diameter, a/D (dimensionless)  
K<sub>b</sub> = cyclone inlet width divided by the cyclone diameter, b/D (dimensionless)  
K<sub>c</sub> = cyclone volume constant (dimensionless)

6 - 41

**Leith and Licht Equation Solution**

5. Calculate the cyclone inertial impact parameter for a single particle size:

$$\Psi = \frac{\rho_p d_p^2 u_{t1} (n+1)}{18\mu_g D} \quad (6-12)$$

$$u_{t1} = \frac{Q}{ab} \quad (6-12a)$$

where  
Ψ = cyclone inertial impact parameter (dimensionless)  
ρ<sub>p</sub> = particle density (lb<sub>m</sub>/ft<sup>3</sup>)  
d<sub>p</sub> = particle diameter (ft)  
u<sub>t1</sub> = tangential velocity of particle at cyclone wall (ft/sec)  
μ<sub>g</sub> = gas viscosity (lb<sub>m</sub>/ft-sec)  
D = cyclone diameter (ft)  
n = vortex exponent (dimensionless)  
Q = gas flow rate (ft<sup>3</sup>/sec)  
a = cyclone inlet height (ft)  
b = cyclone inlet width (ft)

6 - 42

### Leith and Licht Equation Solution

6. Using the values of C,  $\Psi$  and n, determine the collection efficiency using Equation 6-4.
7. Repeat the calculation of  $\Psi$  for a series of particle sizes and determine the efficiency for each size.

This technique is obviously more complex than that of Lapple. However, it allows consideration of the actual cyclone dimensions and, when compared to experimental data, gives more accurate estimates.

6 - 43

### Pressure Drop

$$\Delta P = 0.003 K_C \rho_g v_g^2 \left( \frac{ab}{D_e^2} \right)$$

Where:

- $\Delta P$  = static pressure drop (in WC)
- $K_C$  = 16, for tangential inlet; 7.5, for inlet vane (dimensionless)
- $\rho_g$  = gas density (lb<sub>m</sub>/ft<sup>3</sup>)
- $v_g$  = inlet velocity (ft/sec)
- a = cyclone inlet height (ft)
- b = cyclone inlet width (ft)
- $D_e$  = outlet pipe diameter (ft)

6 - 44

### Pressure Drop

$$\Delta P = K_P \rho_g v_g^2$$

where:

- $\Delta P$  = static pressure drop (in WC)
- $K_P$  = 0.013 to 0.024 (dimensionless)
- $\rho_g$  = gas density (lb<sub>m</sub>/ft<sup>3</sup>)
- $v_g$  = inlet velocity (ft/sec)

6 - 45

### Example 6-2

- A single high efficiency cyclone has an inlet width of 2 ft, an inlet height of 5 ft and an outlet pipe diameter of 5 ft. Estimate the pressure drop when the inlet velocity is 50 ft/sec and the
- gas temperature is 68°F.

**Solution:**

Using Equation 6-13:

$$\Delta P = 0.003 K_C \rho_g v_g^2 \left( \frac{ab}{D_e^2} \right) = 0.003(16) \left( 0.075 \frac{\text{lb}_m}{\text{ft}^3} \right) \left( 50 \frac{\text{ft}}{\text{sec}} \right)^2 \left[ \frac{(5 \text{ ft})(2 \text{ ft})}{(5 \text{ ft})^2} \right] = 3.6 \text{ in WC}$$

Using Equation 6-14:

Since this is a high efficiency cyclone design, assume  $K_P = 0.024$ .

$$\Delta P = K_P \rho_g v_g^2 = 0.024 \left( 0.075 \frac{\text{lb}_m}{\text{ft}^3} \right) \left( 50 \frac{\text{ft}}{\text{sec}} \right)^2 = 4.5 \text{ in WC}$$

### Hopper Design

- Properly sealing solids discharge valve
- Adequately sized hopper throat
- Adequately sloped hopper walls
- Strike plates or vibrators
- Thermal insulation
- Heaters

6 - 47

### Solids Removal Valves

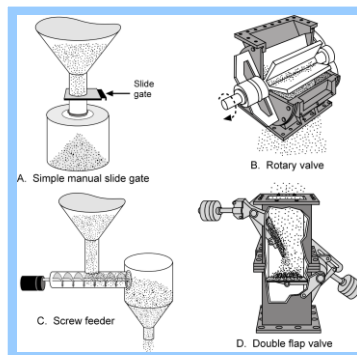

6 - 48

Instrumentation

- Static pressure drop gauges
- Inlet and outlet temperature gauges

6 - 49

Potential Cyclone Control Efficiencies

- Conventional Cyclones
  - 30-90% for PM<sub>10</sub>
  - 0-40% for PM<sub>2.5</sub>
- High Efficiency Single Cyclones
  - 60-95% for PM<sub>10</sub>
  - 20-70% for PM<sub>2.5</sub>
- Multi-Cyclones
  - 80-95% for PM<sub>10</sub>

6 - 50

Cyclone at a Lumber Processing Facility



6 - 51

Cyclone utilized as a primary collector followed by a baghouse



52

Cyclones at a Cotton Gin Mill



6 - 53

Stack Modifications for Testing Due to Cyclonic Flow

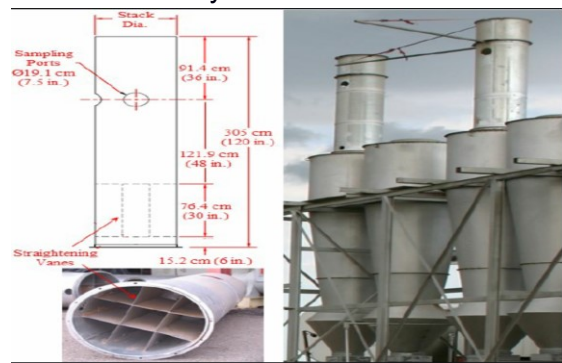

6-54

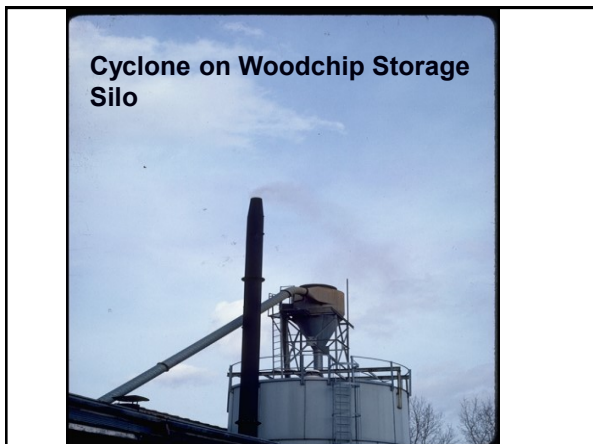

Cyclone on Woodchip Storage Silo

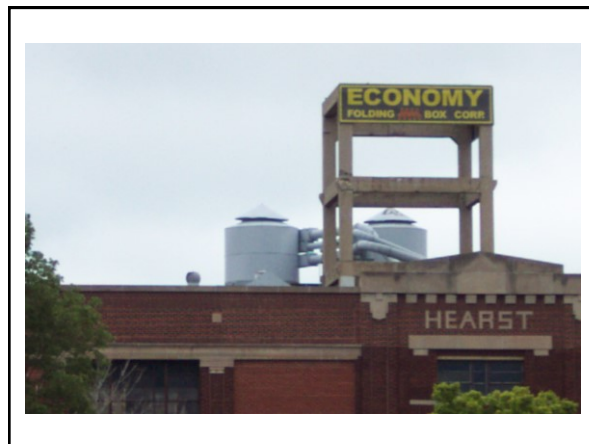

Cyclones at a Flour Milling Facility

6 - 57

TABLE 3. TROUBLESHOOTING GUIDE		
Symptom	Possible Cause	Solution
1. Collection efficiency is lower than expected	Design basis is wrong	Verify specified design conditions and vendor performance predictions are correct If higher $\Delta P$ can be provided by the system air mover and the collection efficiency is close to the desired level, modify cyclone inlet and/or outlet to increase the velocity Replace the cyclone with a cyclone of better design
	Gas leakage into the cyclone	Check and repair any leaks or holes Check to make sure flange connections are properly gasketed and tight
	Inlet or outlet ductwork is improperly designed	Check and repair feeder valves for proper operation and gas tightness Check and repair inlet and outlet ductwork if any flow disturbance is induced into the cyclone
	There is an internal obstruction	Ensure that any access doors are flush and smooth Ensure that there are no instruments or probes sticking into the cyclone flow stream If the cyclone is lined, check for and repair any major erosion that causes sharp edge disturbance to the flow stream If plugging is occurring see item below
2. Plugging	Feeder valve is sized improperly for the particulate loading and density	Resize and replace the airlock valve at the outlet
	Cyclone discharge diameter or dipleg is too small for the particulate loading and apparent density	Redesign and replace lower sections
	Dipleg plugs	Add dipleg purges if problem is caused by poor aeration (although the introduction of purge gas itself can reduce collection efficiency this is preferable to 0% collection resulting from a plug) Check and repair dipleg discharge valve If caused by condensation, insulate and/or heat trace Consider non stick coatings or polished surfaces Periodic cleaning with vibration, air cannon or both Replace with a cyclone with greater internal clearances Provide easy access for cleaning and maintenance
	Particulate matter build up on surfaces	

6 - 58

TABLE 3. TROUBLESHOOTING GUIDE (Continued)		
Symptom	Possible cause	Solution
3. Erosion	Cyclone inlet velocity is too high	Replace the cyclone or modify the inlet so that the inlet velocity is as low as possible (just above the collection velocity of the minimum flow condition)*
	Particulate is abrasive	Reduce the gas flowrate if possible Use the lowest possible inlet velocity Make the cyclone out of more abrasion resistant construction. If a combination of corrosion is occurring with erosion then the materials of construction must first be corrosion resistant since virtually all materials will erode away rapidly when in an oxidized state Use cyclones that have larger diameters Design the installation and cyclone itself so that worn parts can be replaced and/or repaired as economically as possible
4. $\Delta P$ is too high	Design basis is wrong	Verify specified design conditions and vendor performance predictions If the high $\Delta P$ is not causing any real problem, leave it alone. The cyclone should be providing higher collection efficiency than specified Modify air moving portion of the system to accommodate higher $\Delta P$ Enlarge the cyclone inlet or outlet pipe to reduce velocity (note this will reduce the cyclone collection efficiency) Replace the cyclone
	Excess air leaking into upstream ductwork	Repair ductwork
5. $\Delta P$ is too low	Design basis is wrong	Verify specified design conditions and vendor performance predictions If the low $\Delta P$ is not causing any real problem, leave it alone. If the cyclone efficiency is too low by a small margin, modify the inlet and/or outlet to increase velocity. Increase the gas flowrate to the cyclone
	Leaks into the cyclone	Repair
	Reduced swirl intensity	Clear internal obstructions, accumulation on the walls, repair damage

\* Modification to the inlet may require changes to the vortex finder in order to avoid direct impingement of particles or short circuiting of flow.

6 - 59

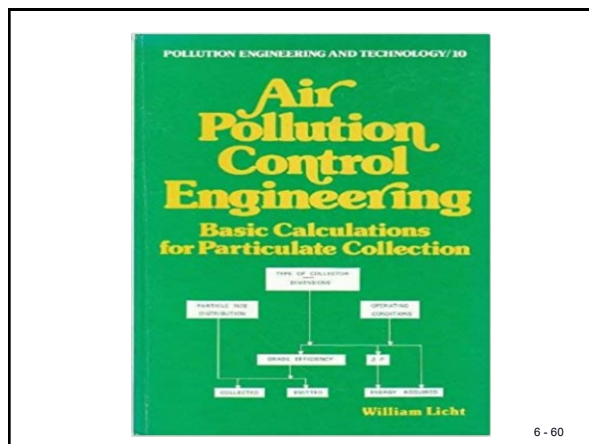

6 - 60

### Chapter 6 Questions

The principal mechanism used to separate particles from the gas stream in a mechanical collector is \_\_\_\_\_.

- a) Brownian diffusion
- b) Inertia
- c) Diffusiophoresis
- d) Thermophoresis
- e) All the above

Answer (b)

6-61

### Chapter 6 Questions

When large diameter cyclones are operated at gas flow rates above the design level, the collection efficiency usually -----.

- a) usually decreases due to increased turbulence within the cylindrical section of the cyclone tube
- b) remains at approximately the same efficiency as when the gas flow rate is at the design flow rate
- c) usually increases due to enhanced inertial separation

Answer a)

6-62

### Chapter 6 Questions

Some of the operating problems common to multiple cyclone type collectors include the following:

- a) air infiltration
- b) inlet vane pluggage
- c) dust discharge tube pluggage
- d) outlet tube pluggage
- e) maldistribution of gas
- f) hopper recirculation
- g) Corrosion
- h) poppet valve failure
- i) outlet tube erosion
- j) all of the above

• Answer: a, b, c, d, e, f, g, i

6-63

### Chapter 6 Questions

In order to evaluate the pressure drop across a multiple cyclone type collector the following data is necessary:

- a) the gas temperature
- b) the gas stream O<sub>2</sub> content
- c) the inlet static pressure
- d) the outlet static pressure
- e) the gas flow rate
- f) the inlet mass concentration
- g) All of the above

h) Answer: a, c, d, e

6-64







**Particle Collection Mechanisms**

A single fiber can be used to describe the various capture mechanisms of a fabric filter. As shown on the next slide, the five basic mechanisms by which particulate can be collected by a single fiber are:

- 1) inertial impaction,
- 2) Brownian diffusion,
- 3) direct interception,
- 4) electrostatic attraction and
- 5) gravitational settling.

7 - 2

**Particle Collection Mechanisms**

- These collection mechanisms, plus sieving, also apply to a fabric filter with a dust cake, such as would be encountered under typical operating conditions.
- Inertial impaction is the dominant collection mechanism within the dust cake. The gas streams movement of the particles results in impaction on the fibers or on already deposited particles.
- Although impaction increases with higher gas stream velocities, these higher velocities reduce the effectiveness of Brownian diffusion.

7 - 3

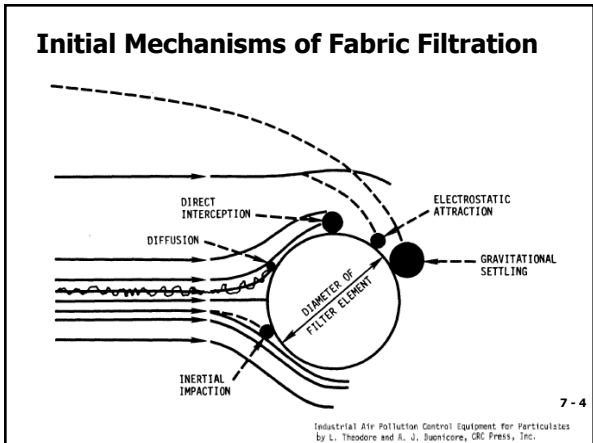

**Particle Collection Steps**

- Capture particulate matter using a filtration media
- Remove collected material from the filter surface
- Dispose of accumulated solids

7 - 5

**Dust Accumulation on Fabrics**

The fabric filtration process or the accumulation of particulate on a new fabric surface occurs in three phases:

- 1) early dust bridging on the fabric substrate,
- 2) subsurface dust cake development, and
- 3) surface dust cake development.

The fabric used in a fabric filter is typically a woven or felted material, which forms the base on which particulate emissions are collected. Woven fabrics consist of parallel rows of yarns in a square array. The figure on the next slide depicts the above particle accumulation on woven fabrics.

7 - 6

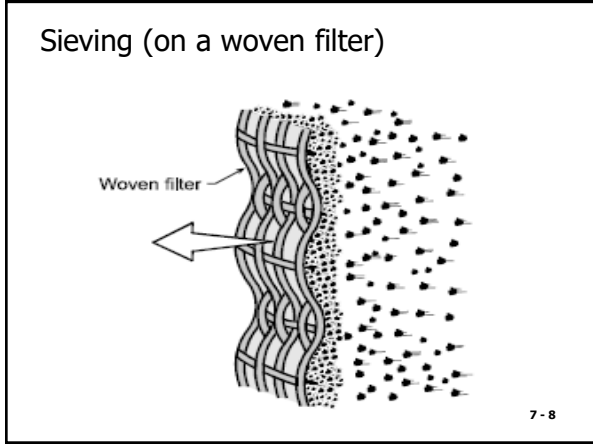
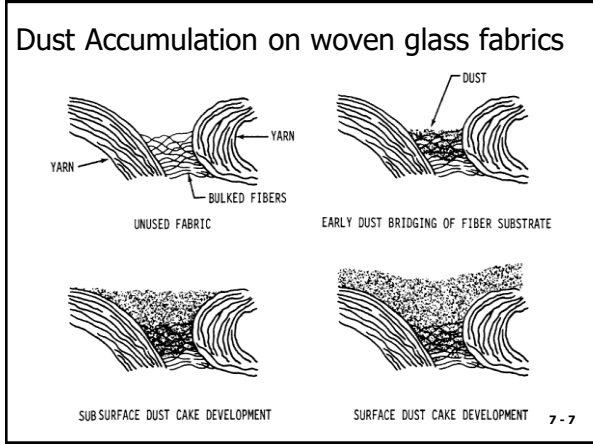

- ### Operating Principles
- Particle collection
  - Pressure drop
  - Filter media blinding and bag blockage
  - Applicability limitations
- 7 - 9

- ### Collection Mechanisms
- Inertial impaction
  - Brownian motion
  - Electrostatic attraction
  - Gravitational settling
- 7 - 10

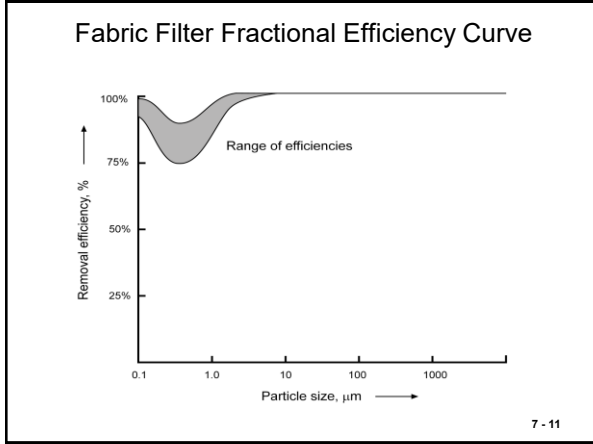

### Air-to-Cloth Ratio

$$A/C \text{ Ratio} \left( \frac{\text{ft}}{\text{min}} \right) = \frac{\text{Actual Gas Flow Rate} \left( \frac{\text{ft}^3}{\text{min}} \right)}{\text{Fabric Surface Area} (\text{ft}^2)}$$

7 - 12

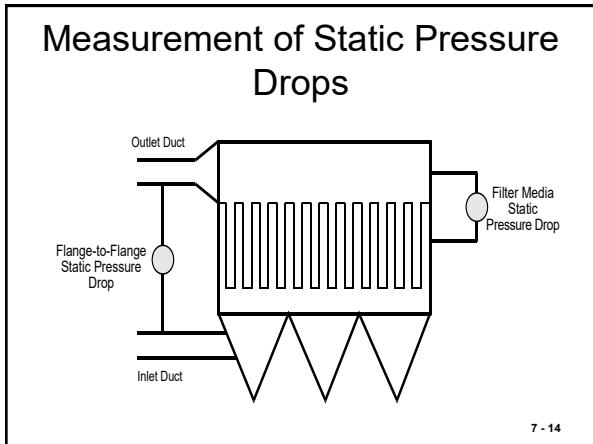
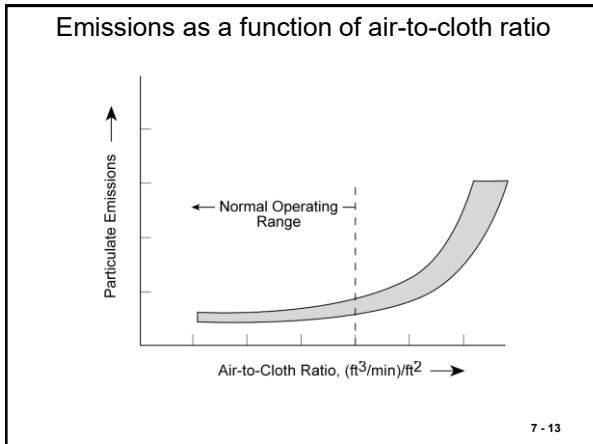

### Pressure Drop (dp)

- Resistance To Airflow
- Inlet Pressure - Outlet Pressure
- Size of Fan
- Filter & Dust Cake

7 - 15

Diagram of the tubing from the clean and dirty air plenums to the pressure gauge and a photo of a Magnehelic® gauge typically used to determine pressure drop with control limits clearly labeled

The diagram on the left shows a schematic of tubing connecting a 'Clean-air Plenum' and a 'Dirty-air Plenum' to a pressure gauge. The gauge has 'High' and 'Low' pressure ports. The photo on the right shows a physical Magnehelic gauge with a scale and a label that reads '50 TO 5 INCHES OF H<sub>2</sub>O'.

7 - 16

### Pressure Drop Modeling

$$\Delta P_t = \Delta P_f + \Delta P_c$$

where

- $\Delta P_t$  = total pressure drop
- $\Delta P_f$  = fabric or media pressure drop
- $\Delta P_c$  = dust cake pressure drop

7 - 17

### Fabric Pressure Drop

$$\Delta P_f = K_1 v_f$$

Where:

- $K_1$  = fabric resistance factor
- $v_f$  = filtration velocity

7 - 18

Dust Cake Pressure Drop

$$\Delta P_c = K_2 c_i v_f^2 t$$

Where:

- $K_2$  = dust cake resistance factor
- $c_i$  = inlet dust concentration
- $v_f$  = filtration velocity
- $t$  = time

7 - 19

Total Pressure Drop

$$\Delta P_t = K_1 v_f + K_2 c_i v_f^2 t$$

$$S = \Delta P_t / v_f = K_1 + K_2 c_i v_f t$$

Where: S = filter drag (in WC/(ft/min))

7 - 20

Filter Drag As A Function Of Dust Loading

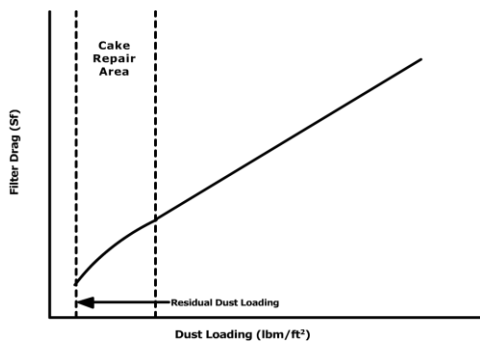

7 - 21

Single Bag Performance

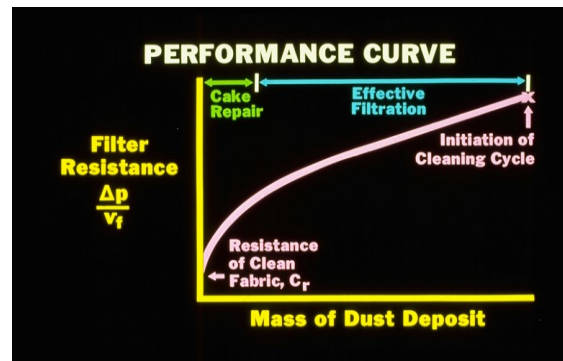

7 - 22

Overall Baghouse Cleaning Cycle Showing Pressure Over Time

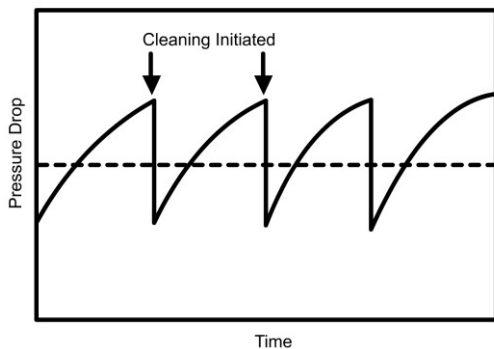

7 - 23

Problems Related to Pressure Drop

- *Pressure Drop Too High* =
  - bag blinding, blockage
  - increase in gas flow rate
  - fugitive emissions
- *Pressure Drop Too Low* =
  - bag failure
  - inleakage

7 - 24

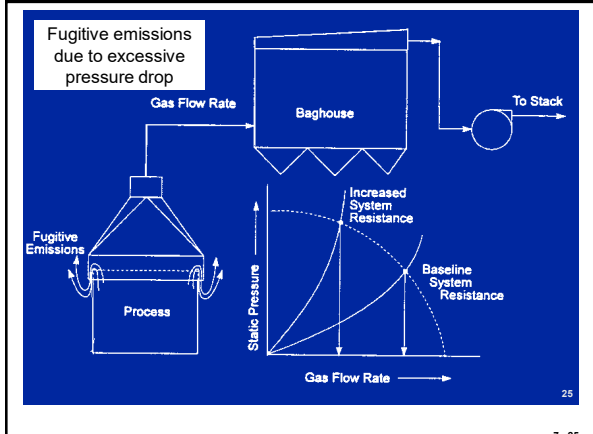

### Blinding and Bag Blockage

- Water
- Lubricating oil
- Condensed organic
- Submicrometer particles
- Hopper overflow or bridging



### Applicability Limitations

- Blinding
- Large particle abrasion
- Fire or explosion
- Gas temperature

### Fabric Filter Systems

- Cleaning method
- Operating mode

### Operating Modes

- Intermittent
- Periodic
- Continuous

### Cleaning Method

- Shaker
- Reverse air
- Pulse jet

7 - 31

### Shaking Baghouses

• Mechanical shaking is accomplished by using a motor that drives a shaft to move a rod connected to the bags. It is a low energy process that gently shakes the bags to remove deposited particles. The shaking motion and speed depends upon the vendor's design and the composition of dust deposited on the bag. The shaking motion can be either in a horizontal or vertical direction, with the horizontal being the most often used. The tops of the bags in shaker baghouses are sealed or closed and supported by a hook or a clasp. Bags are open at the bottom and attached to a cell plate (bag plate).

7 - 32

### Shaker Fabric Filter

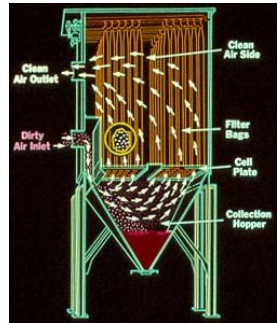

7 - 33

### Shaker fabric filter

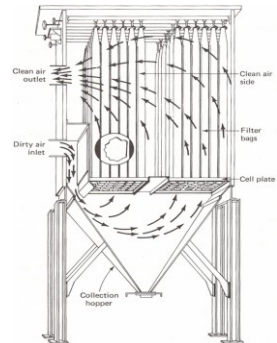

7 - 34

### Shaker Mechanism

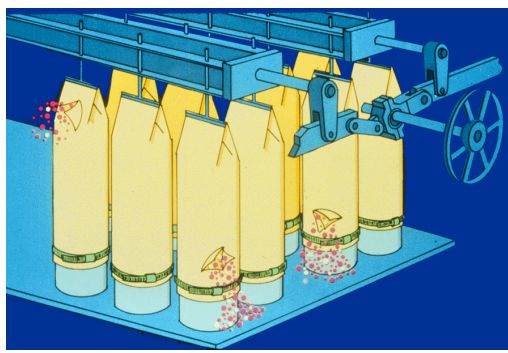

7 - 35

Shaker Motor and Hangers

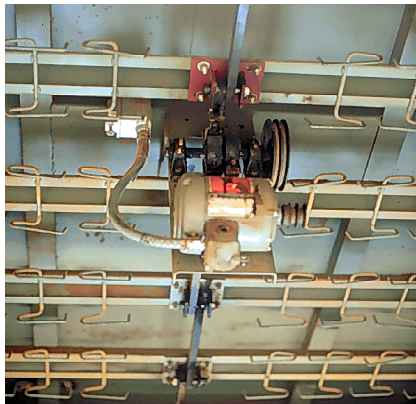

7 - 36

Reverse Air Baghouses

- Reverse air, the simplest cleaning mechanism, is accomplished by stopping the flow of dirty gas into the compartment and backwashing the compartment with a low pressure flow of air. Dust is removed by merely allowing the bags to collapse, thus causing the dust cake to break and fall into the hopper. The cleaning action is very gentle, allowing the use of less abrasion resistant fabrics such as Fiberglas®. Reverse air cleaning is generally used for cleaning woven fabrics. Cleaning frequency varies from 30 minutes to several hours, depending on the inlet dust concentration. The cleaning duration is approximately 10 to 30 seconds; the total time is 1 to 2 minutes including valve opening and closing and dust settling.

7 - 37

Reverse Air Baghouses

- Reverse air cleaning baghouses are usually compartmentalized to permit a section to be off-line for cleaning. Dust can be collected on either the inside or outside of the bag. Normally dust is collected on the inside of the bag, the bag being open at the bottom and sealed by a metal cap at the top. Bags are supported by small steel rings sewn to the inside of the bag. The rings are placed every 4 to 18 inches throughout the bag length, depending on the length and diameter of the bag, to prevent complete collapse during the cleaning cycle.

7 - 38

Reverse Air Baghouses

- Complete collapse of the bag would prevent the dust from falling into the hopper. Reverse air baghouses use very large bags (as compared to shaker or pulse jet baghouses) ranging from 8 to 18 inches in diameter and from 20 to 40 feet in length. Air for cleaning is supplied by a separate fan which is normally much smaller than the main system fan, since only one compartment is cleaned at a time.

7 - 39

Reverse Air Cleaning

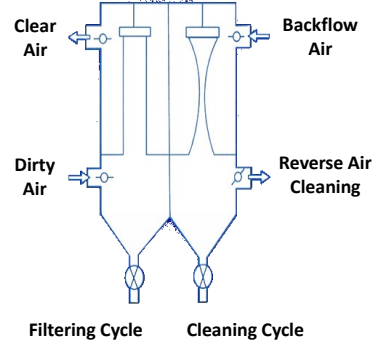

7 - 40

Reverse air cleaning system

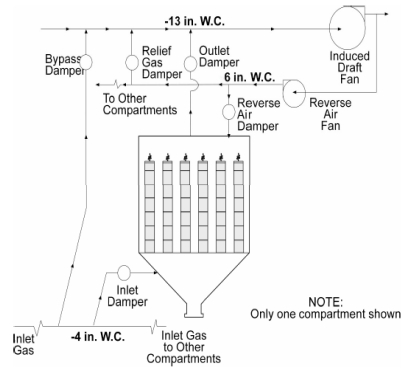

7 - 41

Clamp-and-thimble and Snap Ring Bag Attachments

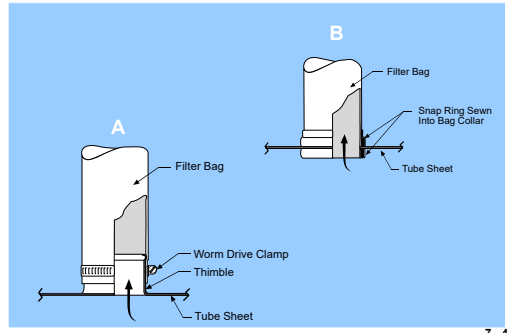

7 - 42

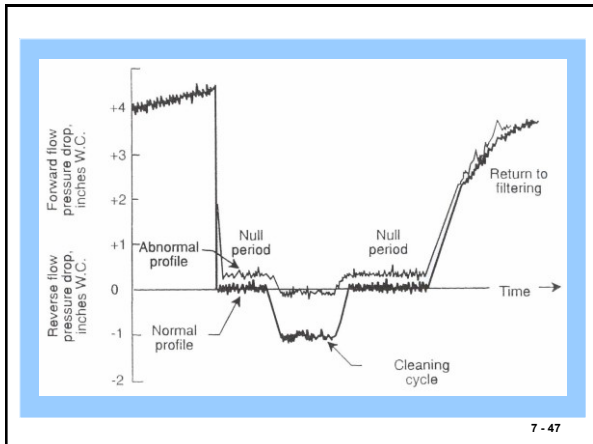
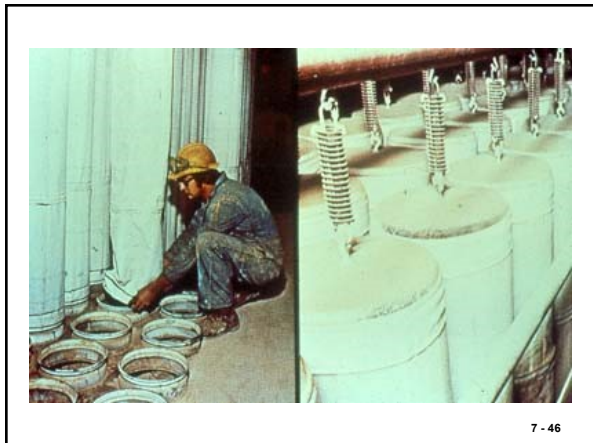
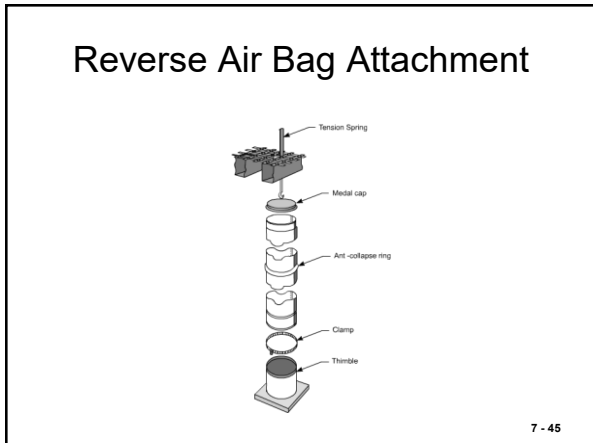
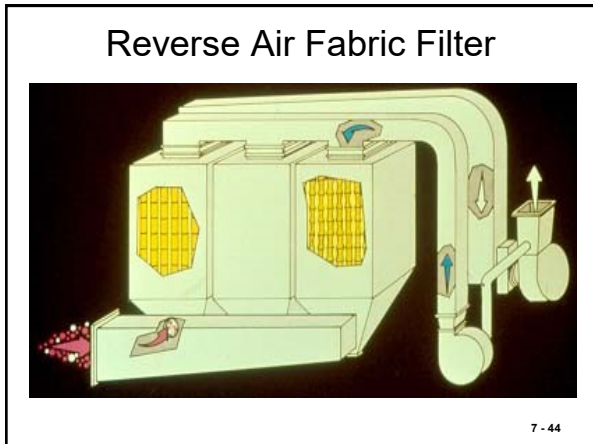
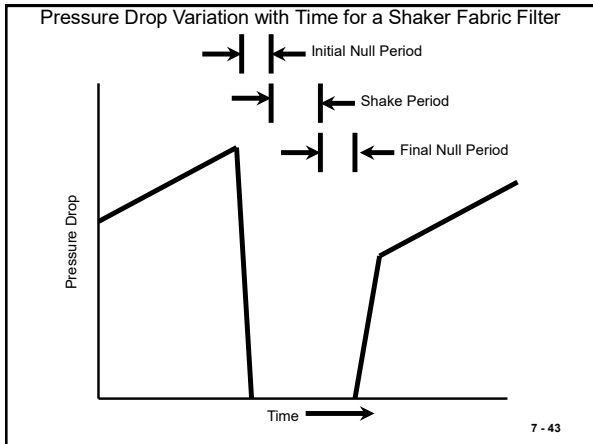



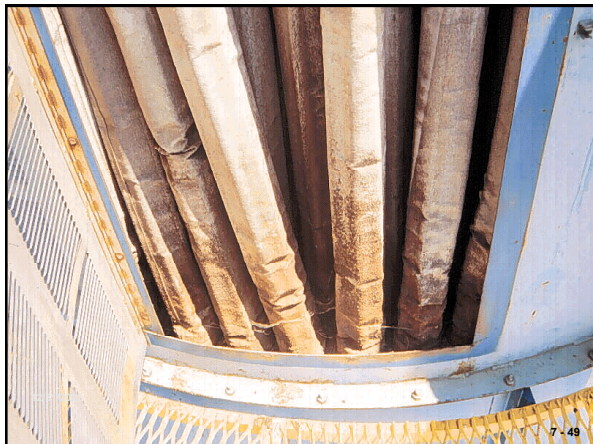

### Reverse Air Cleaning System Problems

- Inadequate reverse air flow
- Leakage through poorly sealed dampers
- Improper bag tension
- Corrosion

7 - 50

### Pulse Jet Fabric Filter

7 - 51

### Diagram of pulse jet cleaning system

7 - 52

### Pulse Jet Fabric Filter

7 - 53



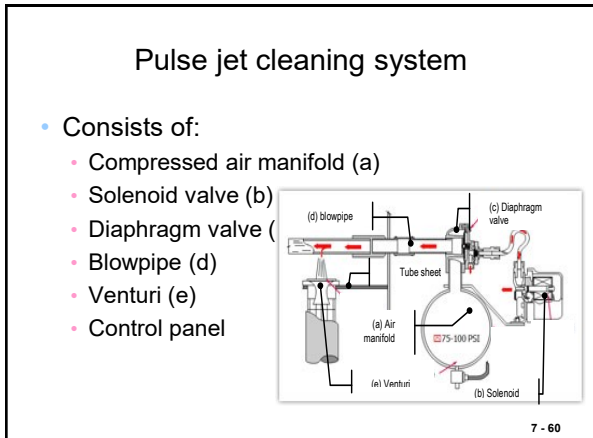
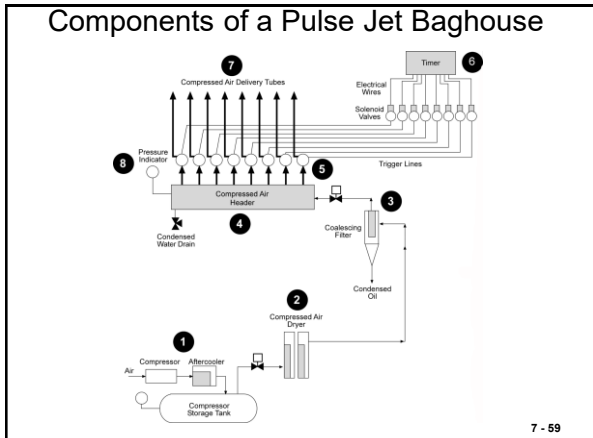
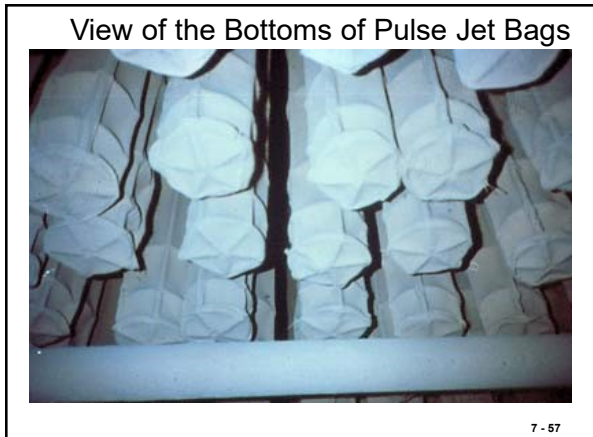
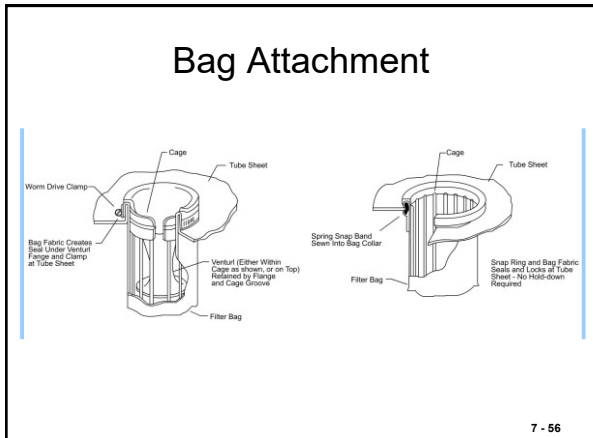



### Compressed air pressure

- Factor for cleaning efficiency and power consumption
- It depends on:
  - blowpipe alignment
  - diameter of the blowpipe
  - injection hole diameter
  - distance between blowpipe and venturi
  - venturi design
  - material density
  - bag length and diameter.
- Practical range is 4 to 6 bars (60 to 90 psi).



7 - 62

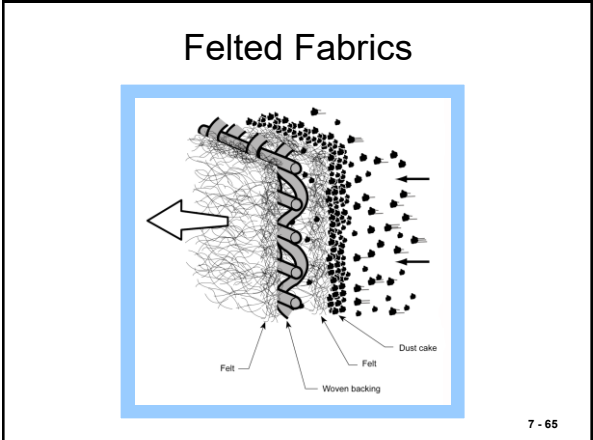
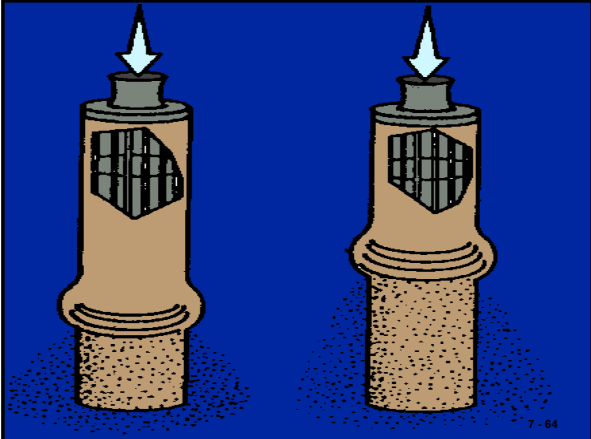

### Pulse Jet Cleaning System Problems

- Cage/bag misalignment
- Low compressed air pressure
- Contaminated compressed air
- Diaphragm valve leakage or freezing
- Loose, misaligned pulse pipe
- Timer or differential pressure sensor failure
- Excessive cleaning frequency

7 - 66



7 - 67

## Bag Blinding

- Bag blinding is a condition where the particles become embedded in the filter over time and are not removed by the cleaning process. Submicron particles can be driven into fabric weave, essentially blocking air flow. This results in reduced gas flow or an increased pressure drop across the filter. If the filter or cartridge cannot be cleaned readily nor the pores reopened, this condition is referred to as permanent blinding.

7 - 68

## Bag Blinding

- A dust cake is beneficial for collecting more particulate matter, but some pore space is needed for air flow.
- Moisture can be a potential problem, although in some situations, moisture might be added to enhance cleaning. Extreme version called “mudding” can occur when the dust cake absorbs water and builds layer of mud on bag, blocking air flow and impairing mechanical cleaning motion.

7 - 69

## Mudding of dust due to excessive moisture



7 - 70

## Performance Evaluation

- Fabric selection
- Air-to-cloth ratio
- Approach velocity
- Bag spacing and length
- Bag accessibility
- Cleaning system design
- Hopper design
- Bypass dampers
- Instrumentation

7 - 71

## Filtration Media

- Woven fabric
- Felted fabric
- Membrane fabric
- Sintered metal fiber
- Ceramic cartridge

7 - 72

Ceramic Catalyst Filter

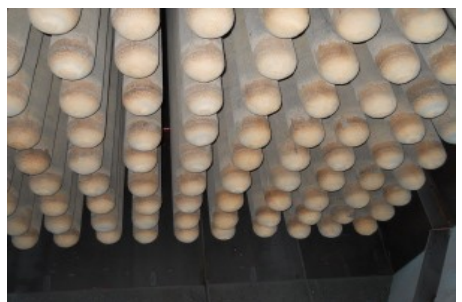

<https://tri-mer.com/hot-gas-treatment/high-temperature-filter.html> 7 - 73

Fabric Selection

- Maximum temperature of the gas stream
- Composition of the gas stream
- Physical abrasion
- Fabric flex conditions
- Tensile strength

7 - 74

Temperature and Acid Resistance Characteristics

Generic Name	Common or Trade Name	Maximum Temperature, °F		Acid Resistance
		Continuous	Surge	
Natural Fiber, Cellulose	Cotton	180	225	Poor
Polyolefin	Polyolefin	190	200	Good to Excellent
Polypropylene	Polypropylene	200	225	Excellent
Polyamide	Nylon®	200	225	Excellent
Acrylic	Orlon®	240	260	Good
Polyester	Dacron®	275	325	Good
Aromatic Polyamide	Nomex®	400	425	Fair
Polyphenylene Sulfide	Ryton®	400	425	Good
Polyimide	P-84®	400	425	Good
Fiberglass	Fiberglass	500	550	Fair
Fluorocarbon	Teflon®	400	500	Excellent
Stainless Steel	Stainless Steel	750	900	Good
Ceramic	Nestel®	1300	1400	Good

7 - 75

Fabric Resistance to Abrasion and Flex

Generic Name	Common or Trade Name	Resistance to Abrasion and Flex
Natural Fiber, Cellulose	Cotton	Good
Polyolefin	Polyolefin	Excellent
Polypropylene	Polypropylene	Excellent
Polyamide	Nylon®	Excellent
Acrylic	Orlon®	Good
Polyester	Dacron®	Excellent
Aromatic Polyamide	Nomex®	Excellent
Polyphenylene Sulfide	Ryton®	Excellent
Polyimide	P-84®	Excellent
Fiberglass	Fiberglass	Fair
Fluorocarbon	Teflon®	Fair
Stainless Steel	Stainless Steel	Excellent
Ceramic	Nestel®	Fair

7 - 76

Plain weave or checkerboard

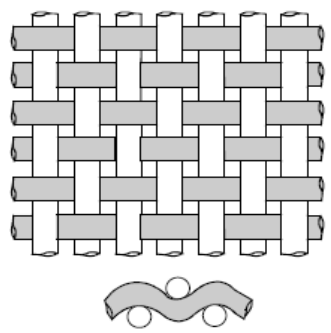

7 - 77

Twill weave patterns (2/1 and 3/1)

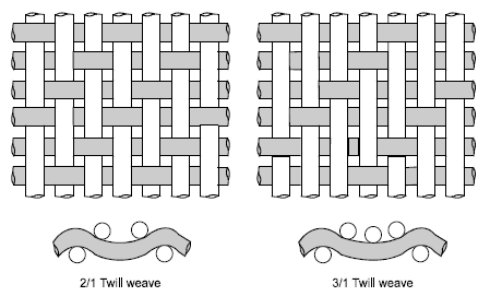

7 - 78

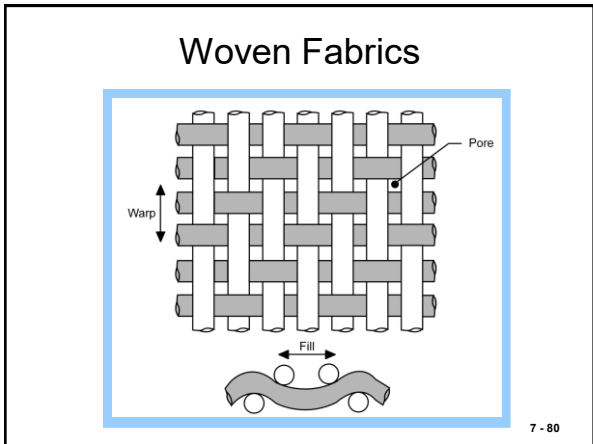
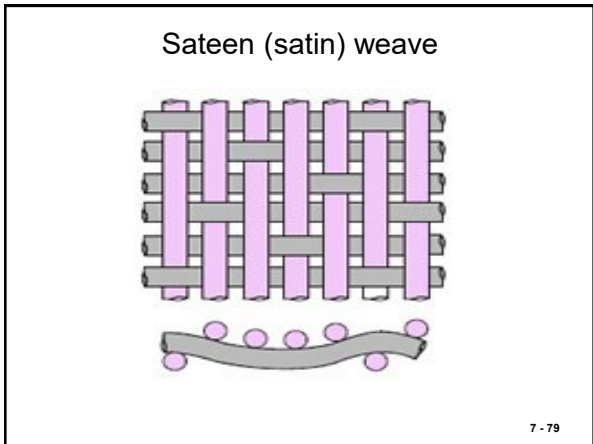

Industrial Baghouse Filter Bags for the Metals Processing Industry | Gore

7 - 81

Generic name	Fiber	Maximum temperature				Acid resistance	Alkali resistance	Flex abrasion resistance	Relative cost
		Continuous		Surges					
		°F	°C	°F	°C				
Natural fiber cellulose	Cotton	180	82	225	107	poor	excellent	average	0.4
Polyolefin	Polypropylene	190	88	200	93	excellent	excellent	good	0.5
Natural fiber protein	Wool	200	93	250	121	good	poor	average	0.8
Polyamide	Nylon	200	93	250	121	poor to fair	excellent	excellent	0.6
Acrylic	Orlon®	240	116	260	127	very good	fair	average	0.7
Polyester	Dacron®	275	135	325	163	good	fair	excellent	0.5
Aromatic polyamide	Nomex®	400	204	425	218	fair	very good	very good	2.0
Fluoro-carbon	Teflon®	450	232	500	260	excellent except poor for fluorine	excellent except poor for trifluoride, chlorine, and molten alkaline metals	fair	6.7
Glass	Fiberglass® or glass	500	260	550	288	good	poor	poor to fair	1.0
Polymer	PSA®	450	232	500	260	good	fair	fair	2.5
Polymer	Ryton®	375	191	450	232	excellent	excellent	good	2.5-4.0

Sources: Mokenna and Turner 1989; Greiner 1993

7 - 82

- Types of Filters
- Natural
    - Cotton
    - Wool
  - Glass
    - Fiberglass
  - Stainless steel
  - Synthetic
    - Nylon
    - Dynel®
    - Orion®
    - Dacron®
    - Teflon
- 7 - 83

Temperature and Acid Resistance Characteristics

Generic Name	Common or Trade Name	Maximum Temperature, °F		Acid Resistance
		Continuous	Surges	
Natural Fiber, Cellulose	Cotton	180	225	Poor
Polyolefin	Polyolefin	190	200	Good to Excellent
Polypropylene	Polypropylene	200	225	Excellent
Polyamide	Nylon®	200	225	Excellent
Acrylic	Orlon®	240	260	Good
Polyester	Dacron®	275	325	Good
Aromatic Polyamide	Nomex®	400	425	Fair
Polypheylene Sulfide	Ryton®	400	425	Good
Polyimide	P-84®	400	425	Good
Fiberglass	Fiberglass	500	550	Fair
Fluorocarbon	Teflon®	400	500	Excellent
Stainless Steel	Stainless Steel	750	900	Good
Ceramic	Nextel®	1300	1400	Good

7 - 84



- Remedia Catalyst Filter System
  - [GORE REMEDIA Catalytic Filters | Dioxin & Furan Filtration | Gore](#)
- 7 - 86

### Air-to-Cloth Ratio

$$A/C \text{ Ratio} \left( \frac{\text{ft}}{\text{min}} \right) = \frac{\text{Actual Gas Flow Rate} \left( \frac{\text{ft}^3}{\text{min}} \right)}{\text{Fabric Surface Area} (\text{ft}^2)}$$

7 - 87

### Bag Area

$$A = \pi DL$$

$$A = 2ndh$$

7 - 88

### Air-to-Cloth Ratios in Various Industrial Categories

Industry	Shaker	Reverse Air	Pulse Jet
Basic oxygen furnaces	2.5-3.0	1.5-2.0	6-8
Brick manufacturers	2.5-3.2	1.5-2.0	9-10
Coal-fired boilers	1.5-2.5	1.0-2.0	3-5
Electric arc furnaces	2.5-3.0	1.5-2.0	6-8
Ferroalloy plants	2.0	2.0	9
Grey iron foundries	2.5-3.0	1.5-2.0	7-8
Lime kilns	2.5-3.0	1.5-2.0	8-9
Municipal incinerators	1.5-2.5	1.0-2.0	2.5-4.0
Phosphate fertilizer	3.0-3.5	1.8-2.0	8-9
Portland cement kilns	2.0-3.0	1.2-1.5	7-10

7 - 89

Example Problems

7 - 90

Examples 7-1 and 7-2

7 - 91

Example 7-1

Calculate the gross and net air-to-cloth ratios for a reverse air baghouse with 20 compartments, 360 bags per compartment, a bag length of 30 ft, and a bag diameter of 11 inches. Use an actual gas flow rate of  $1.2 \times 10^6 \text{ ft}^3/\text{min}$ . Assume that two compartments are out of service when calculating the net air-to-cloth ratio.

Solution:

$$\begin{aligned} \text{Bag area} &= \pi DL \\ \text{Area/bag} &= \pi (11 \text{ inches})(\text{ft}/12 \text{ in.}) 30 \text{ ft} = 86.35 \text{ ft}^2/\text{bag} \end{aligned}$$

The gross air-to-cloth ratio is calculated assuming that all the bags are in service.

7 - 92

Example 7 - 1 (cont.)

Total number of bags = (360 bags/compartment)(20 compartments) = 7,200 bags

Total fabric area = (7,200 bags)(86.35 ft<sup>2</sup>/bag) = 621,720 ft<sup>2</sup>

$$(A/C)_{\text{gross}} = \frac{1.2 \times 10^6 \text{ ft}^3/\text{min}}{621,720 \text{ ft}^2} = 1.93 (\text{ft}^3/\text{min})/\text{ft}^2$$

The net air-to-cloth ratio is calculated by subtracting the compartments that are not in filtering service.

Total number of bags = (360 bags/compartment)(18 compartments) = 6,480 bags

Total fabric area = (6,480 bags)(86.35 ft<sup>2</sup>/bag) = 559,548 ft<sup>2</sup>

$$(A/C)_{\text{net}} = \frac{1.2 \times 10^6 \text{ ft}^3/\text{min}}{559,548 \text{ ft}^2} = 2.14 (\text{ft}^3/\text{min})/\text{ft}^2$$

7 - 93

Example 7-2

Calculate the gross and net air-to-cloth ratios for a cartridge baghouse with 4 compartments, 16 cartridges per compartment, a cartridge length of 2 ft, and a cartridge diameter of 8 inches. Use a pleat depth of 1.5 inches and a total of 36 pleats in the cartridge. Use an actual gas flow rate of 4,000 ft<sup>3</sup>/min. Assume one compartment is out of service when calculating the net air-to-cloth ratio.

Solution:

$$\begin{aligned} \text{Cartridge area} &= 2\pi dh \\ \text{Area/cartridge} &= 2(36 \text{ pleats})(1.5 \text{ in.}/(12 \text{ in. per ft.}))(2 \text{ ft}) = 18 \text{ ft}^2 \end{aligned}$$

The gross air-to-cloth ratio is calculated assuming that all the bags are in service.

$$\begin{aligned} \text{Total number of cartridges} &= (16 \text{ cartridges/compartment})(4 \text{ compartments}) \\ &= 64 \text{ cartridges} \end{aligned}$$

Total fabric area = (64 cartridges)(18 ft<sup>2</sup>/cartridge) = 1,152 ft<sup>2</sup>

$$(A/C)_{\text{gross}} = \frac{4,000 \text{ ft}^3/\text{min}}{1,152 \text{ ft}^2} = 3.47 (\text{ft}^3/\text{min})/\text{ft}^2$$

7 - 94

Example 7- 2 (cont.)

The net air-to-cloth ratio is calculated by subtracting the compartments that are not in filtering service.

$$\begin{aligned} \text{Total number of cartridges} &= (16 \text{ cartridges/compartment})(3 \text{ compartments}) \\ &= 48 \text{ cartridges} \end{aligned}$$

Total fabric area = (48 cartridges)(18 ft<sup>2</sup>/cartridge) = 864 ft<sup>2</sup>

$$(A/C)_{\text{net}} = \frac{4,000 \text{ ft}^3/\text{min}}{864 \text{ ft}^2} = 4.62 (\text{ft}^3/\text{min})/\text{ft}^2$$

7 - 95

Gas Approach Velocity in a Pulse Jet Baghouse (correction)

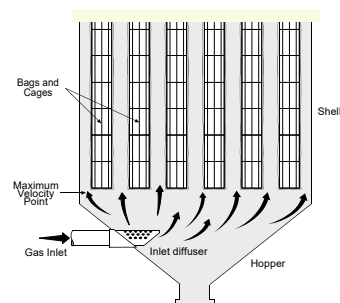

7 - 96



### Example 7-3

7 - 97

#### Example 7-3

What is the difference in gas approach velocities for two identical pulse jet fabric filters with the following design characteristics?

Characteristic	Unit A	Unit B
Compartment area, ft <sup>2</sup>	130	130
Number of bags	300	300
Bag diameter, in.	6	6
Bag height, ft	10	10
Air-to-cloth ratio, (ft <sup>3</sup> /min)/ft <sup>2</sup>	5	8

#### Solution:

The bag area for both units is identical. It is calculated using the circumference of the bag times the length.

$$\text{Bag area} = \pi DL = \pi(6 \text{ in.})(1 \text{ ft } 12 \text{ in.})(10 \text{ ft}) = 15.7 \text{ ft}^2/\text{bag}$$

$$\text{Total bag area} = (300 \text{ bags})(15.7 \text{ ft}^2/\text{bag}) = 4,710 \text{ ft}^2$$

$$\text{Total gas flow rate, Unit A} = \frac{5(\text{ft}^3/\text{min})}{\text{ft}^2}(4,710 \text{ ft}^2) = 23,550 \text{ ft}^3/\text{min}$$

$$\text{Total gas flow rate, Unit B} = \frac{8(\text{ft}^3/\text{min})}{\text{ft}^2}(4,710 \text{ ft}^2) = 37,680 \text{ ft}^3/\text{min}$$

7 - 98

### Example 7 - 3 (cont.)

The area for gas flow at the bottom of the pulse jet bags is identical in both units.

$$\begin{aligned} \text{Area for flow} &= \text{total area} - \text{bag projected area} \\ &= \text{total area} - (\text{number of bags})(\text{circular area of bag at bottom}) \\ &= 130 \text{ ft}^2 - (300)(\pi D^2/4) \\ &= 130 \text{ ft}^2 - 58.9 \text{ ft}^2 \\ &= 71.1 \text{ ft}^2 \end{aligned}$$

$$\text{Gas approach velocity for Unit A} = \frac{23,550 \text{ ft}^3/\text{min}}{71.1 \text{ ft}^2} = 331 \text{ ft}/\text{min}$$

$$\text{Gas approach velocity for Unit B} = \frac{37,680 \text{ ft}^3/\text{min}}{71.1 \text{ ft}^2} = 530 \text{ ft}/\text{min}$$

7 - 99

### Bag Spacing and Length

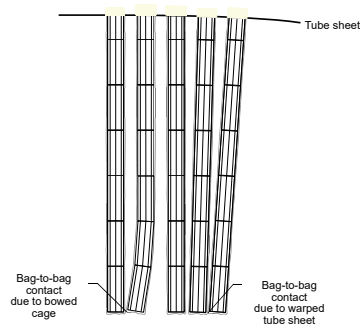

7 - 100

### Bag Accessibility

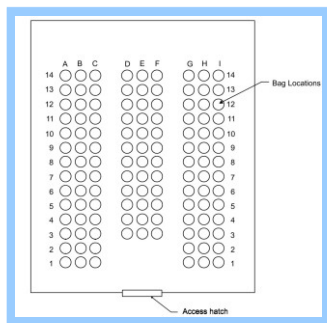

7 - 101

### Hopper Design

- Properly sealing solids discharge valve
- Adequately sized hopper throat
- Adequately sloped hopper walls
- Strike plates or vibrators
- Thermal insulation
- Heaters

7 - 102

### Performance Evaluation

- Fabric selection
- Air-to-cloth ratio
- Approach velocity
- Bag spacing and length
- Bag accessibility
- Cleaning system design
- Hopper design
- Bypass dampers
- Instrumentation

7 - 103

### Instrumentation

- Static pressure drop gauges
- Inlet and outlet gas temperature gauges
- Bag break detector
- Opacity monitor

7 - 104

### Exhaust Cooling Methods

Method	What it does	Advantage/disadvantage
Dilution	Dilution with additional air	Easiest and cheapest. But requires the baghouse to be larger to handle increased air volume. Also may cause intake of ambient moisture and contaminants.
Radiation cooling	Use of long uninsulated ducts for the gas stream to cool as heat radiates from the duct walls. Ducts can be designed in "U" shapes to allow more duct surface area to be exposed for cooling	Radiation cooling is only effective to cool gas temperatures above 572 °F or 300 °C. Below this temperature requires lots of surface area, lengthy duct runs, and increased fan horsepower. Precise temperature control is difficult and there is a possibility of duct plugging due to particle build-up.
Evaporative cooling	Injection of fine water droplets into the gas stream. The droplets absorb heat from the gas as they evaporate. Spray nozzles are located in a quench chamber or in the duct preceding the baghouse.	Gives a great amount of controlled cooling at a lower installation cost. Temperature control can be flexible and accurate. However, this cooling method may increase the exhaust volume to the baghouse. The biggest problem is keeping the gas temperature above the dew point of the gas (SO, NO2, HCl, etc.) of the gases may condense on the bags causing rapid bag deterioration.

7 - 105



**Dampers For Dilution Cooling**

7 - 106

### Radiation Cooling Equipment



107

### Examples of Typical Baghouse Installations

Industry	Process dust concentration (gr/ft <sup>3</sup> )	Baghouse	Fabrics	Temperature (°F)	Air-to-cloth ratio (cfm/ft <sup>2</sup> )
Aluminum furnaces scrap conveyor	6 to 20	Shaker	Nomex®	250 to 375	2.0 to 2.5 : 1
		Pulse jet	Orlon Polyester	100	7.0 to 8.0 : 1
Asphalt batch plants		Pulse jet	Nomex®	250	4.0 to 6.0 : 1
Coal fired boilers (1.5% sulfur coal)		Reverse air	Glass	350 to 450	2.0 : 1
		Pulse jet	Teflon®	300 to 450	4.0 : 1
Coal processing pulverizing mill dryer roller Mill crusher		Pulse jet	Nomex® felt	240	4 to 6 : 1
			Nomex® felt	400	5 to 7 : 1
			Polyester Felt	225	6:1
			Polypropylene felt	100	7 to 8 : 1
Carbon black		Reverse air	Glass-Teflon® treated or Teflon®		1.5 : 1
Cement clinker cooler crusher venting kiln	10 to 12	Pulse jet	Nomex® felt		5 : 1
		Reverse air	Polyester felt,	400 to 500	5 : 1
		and shake	Gore-Tex®		2 : 1
		Reverse air	Glass		7 - 108

**Examples of Typical Baghouse Installations**

Industry	Process dust concentration (gr/ft <sup>3</sup> )	Baghouse	Fabrics	Temperature (°F)	Air-to-cloth ratio (cfm/ft <sup>2</sup> )
Clay calcining kiln or dryers	25	Pulse jet	Glass felt, Nomex®	300 to 400	6 : 1
Copper smelter	< 2	Shaker	Dacron, Teflon®130		
Cupola furnace (gray iron)	1 to 2	Reverse air shaker	Glass-Teflon® treated Nomex®	550	1.9 : 1
Chemical PVC spray dryer		Reverse air	Acrylic Gore-Tex®	350 to 425	2 to 3.6 : 1
Food sugar storage		Pulse jet	Polyester, Gore-Tex®		10 : 1

7 - 109

**Examples of Typical Baghouse Installations**

Industry	Process dust concentration (gr/ft <sup>3</sup> )	Baghouse	Fabrics	Temperature (°F)	Air-to-cloth ratio (cfm/ft <sup>2</sup> )
Foundry sand casting operation	5 to 10	Pulse jet	Polyester felt	275	6 to 7 : 1
Glass melting furnaces		Reverse air Reverse air and shake	Glass Nomex®	400 to 500 375 to 400	< 2 : 1
Gypsum building materials		Pulse jet	Nomex®		
Lead smelting (battery lead)		Pulse jet	Nomex®, Teflon®	320 to 325	
Lime calcining		Pulse jet	Nomex®	280	
Metal lead oxide processing		Shaker	Dacron, Gore-Tex®		1.5 to 3 : 1

7 - 110

**Examples of Typical Baghouse Installations**

Industry	Process dust concentration (gr/ft <sup>3</sup> )	Baghouse	Fabrics	Temperature (°F)	Air-to-cloth ratio (cfm/ft <sup>2</sup> )
Municipal Incinerators	0.5	Reverse air Pulse jet	Glass Teflon®	300 300	2 : 1 4 : 1
Steel electric arc furnace	0.1 to 0.5	Shaker	Dacron	275	
canopy hood over steel furnace	0.1 to 0.5	Reverse air Pulse jet	Dacron Polyester felt	125 to 250 250	8 : 1
Secondary copper and brass rotary kiln		Shaker	Nomex®	350	
Woodworking furniture manufacturing		Pulse jet	Polyester		10 : 1
Zinc refining coker (zinc oxide)		Pulse jet	Glass felt,	350 to 450	4 to 6 : 1

7 - 111

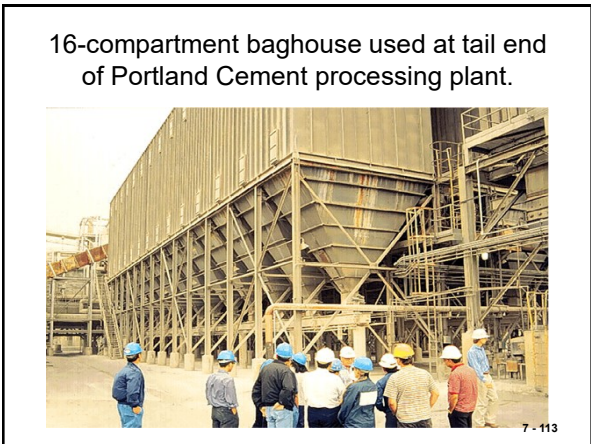

Smaller 1500 CFM Baghouse with carbon after filters on Paint mixing Operation



7 - 115

### Broken Bag Detectors

#### PRINCIPLE OF OPERATION

- When two solids come into contact, an electrical charge is transferred between the two bodies. This charge transfer is known as the triboelectric principle, or contact electrification.
- As particles in a gas stream collide with a sensor placed in the stream, the charge transfer generates a current that can be measured using triboelectric monitoring equipment. The current signal produced by the triboelectric effect is generally proportional to the particulate mass flow, though it can be affected by a number of factors as described below.
- The current, which can be as low as 10-13 amperes, is amplified and transmitted to the processing electronics. The processing electronics are tuned to the specific installation and configured to produce a continuous analog output (i.e., 4-20 mA signal) and/or an alarm at a specific signal level.

7 - 116

### Triboelectric detection Device

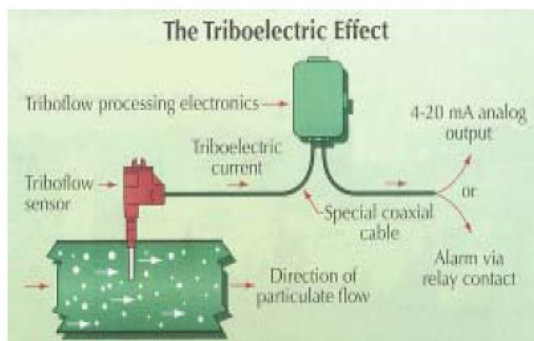

7 - 117

- All fabric filter bags allow some amount of PM to pass through; this constant bleed through is used to establish a baseline signal. The monitoring system detects gradual or instantaneous increases in the signal from the baseline level.
- According to a vendor literature, triboelectric monitoring systems have been shown to detect baseline emissions as low as 0.1 mg/dscm (0.00005 gr/dscf).

<https://www3.epa.gov/ttnemc01/cem/tribo.pdf>

7 - 118

### Triboelectric Monitoring

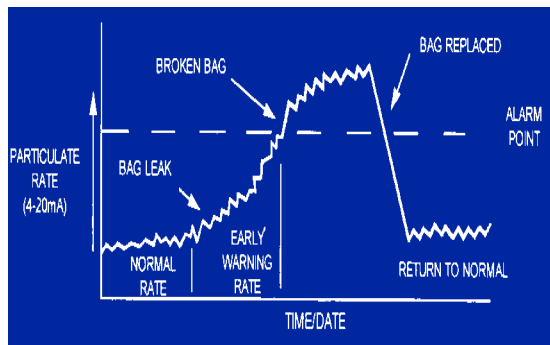

7 - 119

### Effect of response time on a typical baghouse cleaning peak

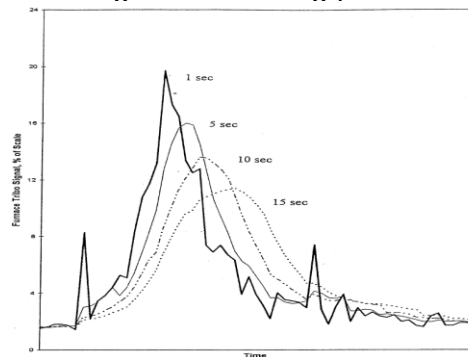

7 - 120

### Sensitivity to Cleaning Cycle

- Based on data analyzed by the EPA, a response time of 5 seconds typically serves to smooth the baseline and dampen momentary high signals not associated with a cleaning cycle peak, but still provides an accurate depiction of the baghouse activity. The previous figure depicts a typical cleaning peak at 1, 5, 10, and 15 seconds of response time. At a 1 second response time, the signal is very jagged. At 5 seconds, it is smoothed out well, without overly dampening the cleaning peak. The response time of 15 seconds provides the most smoothing, but decreases the height of this particular cleaning peak from around 20 percent of scale to approximately 11 percent of scale.

7 - 121

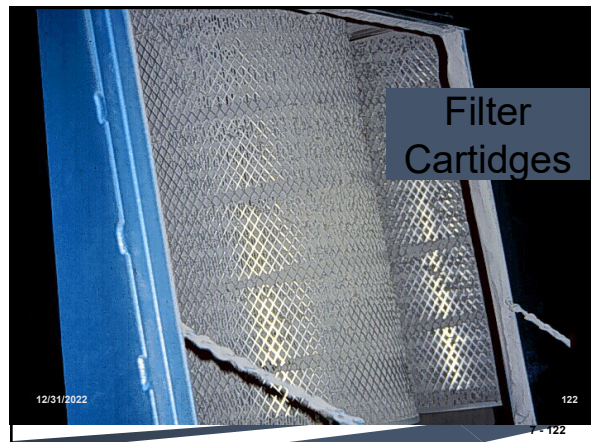

### Filter Cartridges

- There are other types of fabric filter dust collectors. Cartridge filters or cartridge collectors, as shown on the following photos, are another design used for filtering particulate matter. Cartridge collectors tend to be used on smaller industrial processes that have lower exhaust flow rates (usually less than 50,000 cfm) and tend to be good for small particles.

7 - 123

### Filter Cartridge

- The cartridge filters are supported on a tube sheet that is usually mounted near the back of the filter housing. The dirty gas passes from the outside of the filter element to the inside and the dust cake remains on the exterior of the filter media. The filter media is usually a felted material composed of cellulose, polypropylene, or other flex-resistant material and come in several styles and sizes. Cartridge filter type collectors are used in a wide variety of industrial applications.

7 - 124

### Filter Cartridges

- Due to their compact design, they can be used in small collectors located close to the point of particulate matter generation. They are mostly used on gas streams that are less than 400°F, due to the capabilities of the flex resistant, high temperature fabrics and by the limitation of the gasket material used to seal the cartridge filter to the tube sheet.

7 - 125

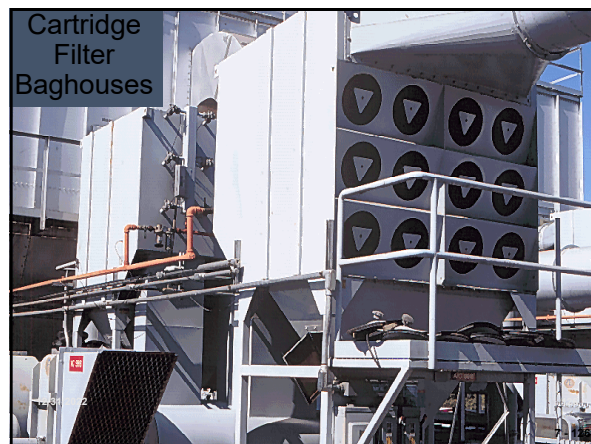

### Cartridge Filters Collectors

7 - 127

### Fiber bed Mist Collector

7 - 128

[Mist Collectors for Asphalt Storage Tanks | Monroe Environmental](#)

### High Energy Air Filtering Indexing Roll Mat

7 - 129

Air Pollution Training Institute EPA 600/2-82-005  
 600/2-82-005  
 Environmental Research Center  
 Research Triangle Park, NC 27711  
 April, 1982

**APTI**  
**Course SI:412**  
**Baghouse Plan Review**  
**Student Guidebook**

7 - 130

United States Environmental Protection Agency

Office of Air Quality Planning and Standards  
Washington DC 20460

February 1984  
EPA 340/1-94-002

**Fabric Filter Inspection and Evaluation Manual**

Stationary Source Compliance Division

7 - 131

EPA/626/1-88/020  
June 1988

**Manual**  
**Operation and Maintenance**  
**Manual for**  
**Fabric Filters**

by  
 FES Associates, Inc.  
 1188 Chester Road  
 Cincinnati, Ohio 45248

Contract No. 68-02-3919  
 Project No. 3087

EPA Project Officer  
 Louis S. Hoyle  
 Gas Cleaning Division  
 Particulate Technology Branch

Air and Energy Engineering Research Laboratory  
 Office of Research and Development  
 U. S. Environmental Protection Agency  
 Research Triangle Park, NC 27711

7 - 132

**Chapter 7 Questions**

The typical air-to-cloth ratio for a pulse jet filter is \_\_\_\_\_.

- a) 0 to 4
- b) 4 to 8
- c) 8 to 12
- d) 12 to 16
- e) 16 to 20

• Answer: b)

7 - 133

**Chapter 7 Questions**

The typical compressed air pressures used on pulse jet collectors is \_\_\_\_\_.

- a) 10 to 50 inches of water
- b) 100 to 200 inches of water
- c) 10 to 60 psig
- d) 60 to 120 psig
- e) 10 to 70 kilopascals
- f) 70 to 140 kilopascals

Answer: d)

7 - 134

**Chapter 7 Questions**

If the diaphragm valves are not working on a pulse jet collector, the following conditions will develop shortly:

- a) the bags will balloon outward away from the support cage
- b) a substantial dust cake will build up on the bags not being cleaned
- c) the opacity will increase
- d) the gas flow rate to the collector will decrease
- e) the pressure drop across the collector will increase
- f) there will be fugitive emissions from the process hood

Answer: b), d), e), f)

7 - 135

**Chapter 7 Questions**

The maximum rated temperature for a fiberglass fabric is -----,

- a) 300°F
- b) 400°F
- c) 500°F
- d) 600°F
- e) 1000°F

• Answer: c)

7 - 136

**Chapter 7 Questions**

The typical air-to-cloth ratios for shaker type and reverse air fabric filters is \_\_\_\_\_.

- a) 60 to 180 feet per minute
- b) 0.25 to 1.0 meters per minute
- c) 1 to 3 feet squared per minute
- d) 4 to 8 feet squared per minute
- e) 8 to 12 feet per minute squared
- f) 1 to 3 feet per minute
- g) 4 to 8 feet per minute
- h) none of the above

Answer: b), f)

7 - 137





## Chapter 8 - Wet Scrubbers



8 - 1

## General Applicability of Particulate Control Systems

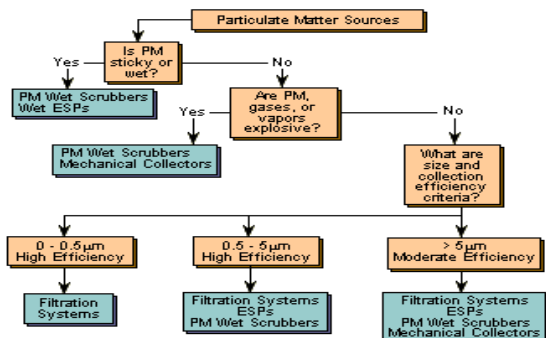

8 - 2

## Wet Scrubbers

Wet scrubbers remove particles from gas streams by capturing the particles in liquid droplets or in sheets of scrubbing liquid (usually water) and then separating the droplets from the gas stream.

Several process variables affect particle capture; they include particle size, the size of liquid droplets, and the relative velocity of the particle and the liquid droplets, with particle size being the most important parameter.

In general, larger particles are easier to collect than smaller ones.

8 - 3

## Relative advantages and disadvantages of wet scrubbers compared to other control devices

Advantages	Disadvantages
<p><b>Small space requirements</b> Scrubbers reduce the temperature and volume of the unsaturated exhaust stream. Therefore, vessel sizes, including fans and ducts downstream, are smaller than those of other control devices. Smaller sizes result in lower capital costs and more flexibility in site location of the scrubber.</p> <p><b>No secondary dust sources</b> Once particles are collected, they cannot escape from hoppers or during transport.</p> <p><b>Handles high-temperature, high-humidity gas streams</b> No temperature limits or condensation problems can occur as in baghouses or ESPs.</p> <p><b>Minimal fire and explosion hazards</b> Various dry dusts are flammable. Using water eliminates the possibility of explosions.</p> <p><b>Ability to collect both gases and particles</b></p>	<p><b>Corrosion problems</b> Water and dissolved pollutants can form highly corrosive acid solutions. Proper construction materials are very important. Also, wet-dry interface areas can result in corrosion.</p> <p><b>High power requirements</b> High collection efficiencies for particles are attainable only at high pressure drops, resulting in high operating costs.</p> <p><b>Water-disposal problems</b> Settling ponds or sludge clarifiers may be needed to meet waste-water regulations.</p> <p><b>Difficult product recovery</b> Dewatering and drying of scrubber sludge make recovery of any dust for reuse very expensive and difficult.</p> <p><b>Meteorological problems</b> The saturated exhaust gases can produce a wet, visible steam plume. Fog and precipitation from the plume may cause local meteorological problems.</p>

8 - 4

## Particle Collection Steps

- Capture particulate matter in droplets, liquid sheets or liquid jets
- Capture droplets entrained in the gas stream
- Treat contaminated liquid prior to reuse or discharge

8 - 5

## Operating Principles

- Collection mechanisms
- Pressure drop
- Gas cooling
- Liquid recirculation
- Liquid-to-gas ratio
- Liquid purge rates
- Alkali addition
- Wastewater treatment
- Mist elimination
- Fans, ductwork and stacks
- Capabilities and limitations

8 - 6

### **Collection Mechanisms**

- Inertial impaction
- Brownian motion
- Electrostatic attraction
- Thermophoresis
- Diffusiophoresis

8 - 7

### ***Particle Capture Mechanisms***

Particulates contact liquid droplets in wet scrubbers through several mechanisms. Impaction is the primary capture mechanism. When waste gas approaches a water droplet, it flows along streamlines around the droplet.

Particles with sufficient inertial force maintain their forward trajectory and impact the droplet. Due to their mass, particles with diameters greater than 10  $\mu\text{m}$  are generally collected using impaction. Turbulent flow enhances capture by impaction.

8 - 8

### ***Particle Capture Mechanisms***

Wet scrubbers capture relatively small dust particles with large liquid droplets. In most wet scrubbing systems, droplets produced are generally larger than 50 micrometers (in the 150 to 500 micrometer range). A substantial portion are small (i.e. less than 5 micrometers) and sub-micrometer-sized particles. The most critical sized particles are those in the 0.1 to 0.5 micrometer range because they are the most difficult for wet scrubbers to collect.

8 - 9

### ***Particle Capture Mechanisms***

Particles dominated by fluid drag forces follow the streamlines of the waste gas. However, particles that pass sufficiently close to a water droplet are captured by interception, capture due the surface tension of the water droplet. Particles of roughly 1.0 to 0.1  $\mu\text{m}$  in diameter are subject to interception. Increasing the density of droplets in a spray increases interception.

8 - 10

Very small-sized particles are subject to Brownian motion, irregular motion caused by random collisions with gas molecules. These particles are captured by the water droplet as they diffuse through the waste gas. Collection due to diffusion is most significant for particles less than 0.5  $\mu\text{m}$  in diameter.

Capture mechanisms that are used less frequently include condensation and electrostatics. In condensation scrubbing, a gas stream is saturated with water vapor and the particle is captured when the water condenses on the particle. In electrostatic scrubbing, contact is enhanced by placing an electrostatic charge on the particle, droplet, or both.

8 - 11

- The primary mechanism by which particles are collected in wet scrubbers is impaction.
- Because of the limited residence time in most scrubbers, Brownian motion is typically not significant.
- Those collectors, like the venturi scrubber, that can collect submicron particles at high efficiency, make up for the lack of particle mass by using impaction at high velocities.

8 - 12

### Impaction

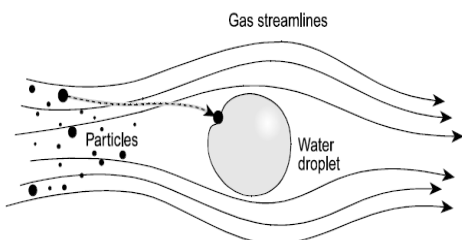

8 - 13

### Interception

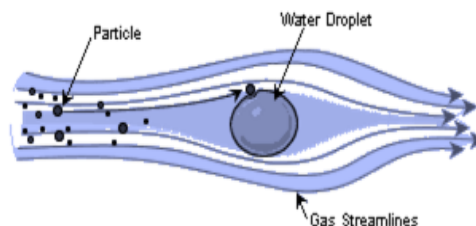

8 - 14

### Random motion or Diffusion

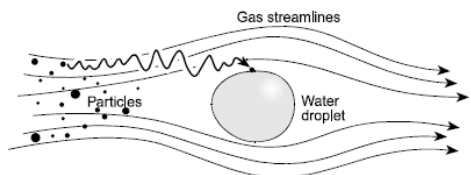

8 - 15

The efficiency of particle collection by impaction is proportional to the inertial impaction parameter shown below.

$$\Psi_I = \frac{C_c d_p^2 \rho_p V_r}{18 \mu_g d_d}$$

where:

- $\Psi_I$  = inertial impaction parameter (dimensionless)
- $C_c$  = Cunningham slip correction factor (dimensionless)
- $d_p$  = physical particle diameter (cm)
- $\rho_p$  = particle density ( $\text{gm/cm}^3$ )
- $V_r$  = relative velocity between particle and droplet (cm/sec)
- $d_d$  = droplet diameter (cm)
- $\mu_g$  = gas viscosity ( $\text{gm/cm sec}$ )

8 - 16

### Brownian Motion

- Brownian motion, or diffusion, is the particle movement caused by the impact of gas molecules on the particle.
- Only very small particles are affected by the molecular collisions, since they possess little mass and, therefore, little inertial tendency.
- Brownian motion begins to be effective as a capture mechanism for particles less than approximately  $0.3 \mu\text{m}$ , and it is significant for particles less than  $0.1 \mu\text{m}$ .
- Most industrial sources of concern in the air pollution field do not generate large quantities of particulate matter in the less than  $0.1 \mu\text{m}$  size range.
- Therefore, in most cases, Brownian motion is not a major factor influencing overall scrubber collection efficiencies.

8 - 17

### Wet Scrubber Fractional Efficiency Curve

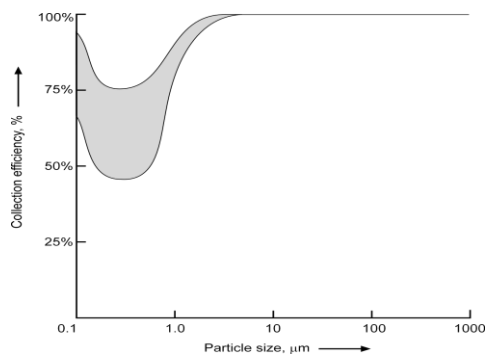

8 - 18

### Pressure Drop

$$\Delta P \propto v^2$$

where:

$\Delta P$  = static pressure drop

v = gas velocity in scrubber

8 - 19

Emissions versus pressure drop for flooded disc scrubbers serving lime kilns (Walker and Hall, 1968)

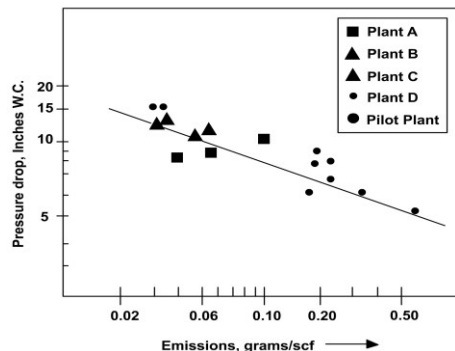

8 - 20

Emissions versus pressure drop for venturi scrubbers serving coal driers (Engineering Science, 1979)

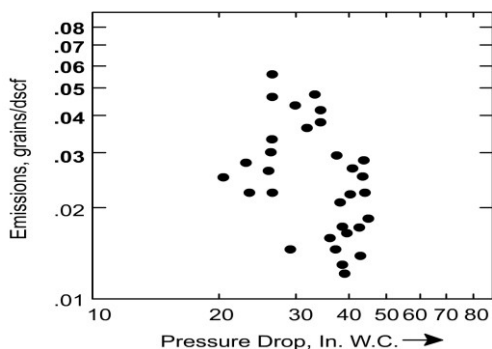

8 - 21

Emissions versus pressure drop for venturi scrubbers serving Q-BOF processes

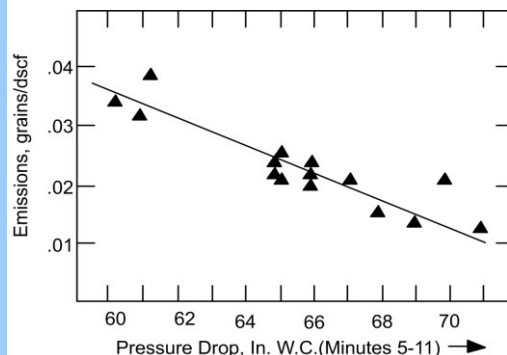

8 - 22

### Operating Principles

- Collection mechanisms
- Pressure drop
- Gas cooling
- Liquid recirculation
- Liquid-to-gas ratio
- Liquid purge rates
- Alkali addition
- Wastewater treatment
- Mist elimination
- Fans, ductwork and stacks
- Capabilities and limitations

8 - 23

### Operating Principles

- Collection mechanisms
- Pressure drop
- Gas cooling
- Liquid recirculation
- Liquid-to-gas ratio
- Liquid purge rates
- Alkali addition
- Wastewater treatment
- Mist elimination
- Fans, ductwork and stacks
- Capabilities and limitations

8 - 24

### Liquid-to-Gas Ratio

$$L/G \text{ Ratio} \left( \frac{\text{gal}}{10^3 \text{ acf}} \right) = \frac{\text{Liquid flow rate} \left( \frac{\text{gal}}{\text{min}} \right)}{\text{Gas flow rate} \left( \frac{10^3 \text{ acf}}{\text{min}} \right)}$$

8 - 25

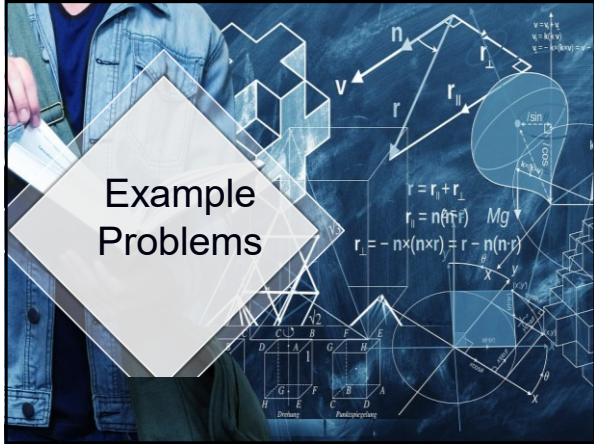

### Example 12-1

8 - 27

### Example 12-1

What is the design liquid-to-gas ratio for a scrubber system that has an outlet gas flow rate of 15,000 acfm, a pump discharge rate of 100 gpm, and a liquid purge rate of 10 gpm? The purge stream is withdrawn from the pump discharge side.

**Solution**

$$\frac{L}{G} = \frac{\text{Inlet liquid flow (gpm)}}{\text{Outlet gas flow rate (1,000 acfm)}}$$

Inlet liquid flow = 100 gpm - 10 gpm = 90 gpm

$$\frac{L}{G} = \frac{90 \text{ gpm}}{15,000 \text{ acfm}} = 0.006 \frac{\text{gal}}{\text{acf}} = 6.0 \frac{\text{gal}}{1,000 \text{ acf}}$$

8 - 28

### Factors Affecting Liquid Purge Rate

- Rate of particulate matter capture
- Maximum acceptable suspended solids concentration
- Rate of dissolved solids precipitation
- Rate of chlorine or fluorine accumulation

8 - 29

### Example 12-2

8 - 30

Estimate the liquid purge rate and recirculation pump flow rate for a scrubber system treating a gas stream of 30,000 acfm (inlet flow) with a particulate matter loading of 0.8 grains per acf. Assume that the scrubber particulate matter removal efficiency is 95% and the maximum suspended solids level desirable in the scrubber is 2% by weight. Use a liquid-to-gas ratio of 8 gallons (inlet) per thousand acf (outlet) and an outlet gas flow rate of 23,000 acfm.

**Solution:**

Calculate the inlet particulate mass:

$$\text{Inlet mass} = 30,000 \frac{\text{ft}^3}{\text{min}} \left( \frac{0.8 \text{ grains}}{\text{ft}^3} \right) \left( \frac{1 \text{ lb}}{7,000 \text{ grains}} \right) = 3.43 \frac{\text{lb}}{\text{min}}$$

Collected mass = 0.95 (Inlet mass) =  $3.26 \frac{\text{lb}}{\text{min}}$

Purge solids of 3.26 lb/min are 2% of the total purge stream, therefore:

$$\text{Purge stream} = \frac{3.26 \frac{\text{lb}}{\text{min}}}{0.02} = 163.0 \frac{\text{lb}}{\text{min}}$$

8 - 31

### Example 12 – 2 (cont.)

A stream with 2% suspended solids has a specific gravity of about 1.02, therefore:

$$\text{Purge stream density} = \left( 8.34 \frac{\text{lb water}}{\text{gal}} \right) (1.02) = 8.51 \frac{\text{lb}}{\text{gal}}$$

$$\text{Purge stream flow rate} = \frac{163.0 \frac{\text{lb}}{\text{min}}}{8.51 \frac{\text{lb}}{\text{gal}}} = 19.2 \frac{\text{gal}}{\text{min}}$$

$$\text{Inlet liquid flow rate} = \left( 23,000 \frac{\text{ft}^3}{\text{min}} \right) \left( 8 \frac{\text{gal}}{1,000 \text{ ft}^3} \right) = 184.0 \frac{\text{gal}}{\text{min}}$$

$$\text{Pump flow rate} = 184.0 \frac{\text{gal}}{\text{min}} + 19.2 \frac{\text{gal}}{\text{min}} = 203.2 \frac{\text{gal}}{\text{min}}$$

8 - 32

## Alkali Addition

$$\text{SO}_3 + \text{Ca(OH)}_2 \rightarrow \text{CaSO}_4 + \text{H}_2\text{O}$$

$$2\text{HCl} + \text{Ca(OH)}_2 \rightarrow \text{CaCl}_2 + 2\text{H}_2\text{O}$$

$$2\text{HF} + \text{Ca(OH)}_2 \rightarrow \text{CaF}_2 + 2\text{H}_2\text{O}$$

8 - 33

## Example 12-3

8 - 34

### Example 12-3

Calculate the amount of calcium hydroxide (lime) needed to neutralize the HCl absorbed from a gas stream having 50 ppmv HCl and a flow rate of 10,000 scfm. Assume an HCl removal efficiency of 95%.

**Solution:**

Calculate HCl absorbed in the scrubbing liquid:

$$50 \text{ ppmv} = \frac{50 \text{ ft}^3 \text{ HCl}}{10^6 \text{ ft}^3 \text{ total}} = 0.00005 \frac{\text{ft}^3 \text{ HCl}}{\text{ft}^3 \text{ total}} = 0.00005 \frac{\text{lb - mole HCl}}{\text{lb - mole total}}$$

$$\text{HCl absorbed} = 10,000 \text{ scfm} \left( \frac{\text{lb - mole}}{385.4 \text{ scf}} \right) \left( 0.00005 \frac{\text{lb - mole HCl}}{\text{lb - mole total}} \right) (0.95)$$

$$= 0.00123 \frac{\text{lb - mole}}{\text{min}}$$

$$\text{Ca(OH)}_2 \text{ required} = \left( \frac{1 \text{ lb - mole Ca(OH)}_2}{2 \text{ lb - mole HCl}} \right) \left( 0.00123 \frac{\text{lb - mole HCl}}{\text{min}} \right)$$

$$= 0.00062 \frac{\text{lb - mole}}{\text{min}} \left( 74 \frac{\text{lb Ca(OH)}_2}{\text{lb - mole}} \right) \left( 60 \frac{\text{min}}{\text{hr}} \right)$$

$$= 2.75 \frac{\text{lb}}{\text{hr}}$$

8 - 35

## Operating Principles

- Collection mechanisms
- Pressure drop
- Gas cooling
- Liquid recirculation
- Liquid-to-gas ratio
- Liquid purge rates
- Alkali addition

- Mist elimination
- Fans, ductwork and stacks
- Capabilities and limitations

8 - 36

### Types of Mist Eliminators

- Chevrons
- Mesh and woven pads
- Tube banks
- Cyclones

8 - 37

### Chevron Type Mist Eliminator

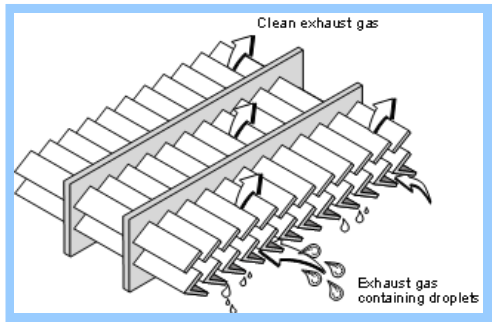

8 - 38

### Mesh and Woven Pads

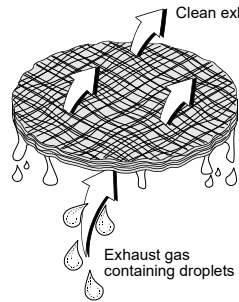

8 - 39

### Tube Bank

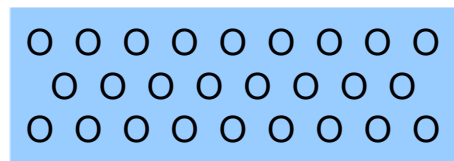

8 - 40

### Cyclonic Mist Eliminator

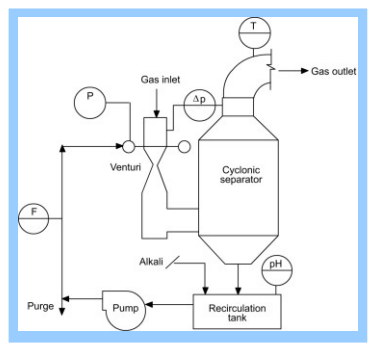

8 - 41

### Mist Eliminator Velocity

$$\text{Velocity} = \frac{\text{Gas flow rate (ACFM)} (\text{min}/60 \text{ sec})}{\text{Mist eliminator area (ft}^2\text{)}}$$

8 - 42

### Maximum Velocities

Mist Eliminator Type	Orientation	Maximum Gas Velocity, ft/sec
Zigzag	Horizontal	15 – 20
Zigzag	Vertical	12 – 15
Mesh Pad	Horizontal	15 – 23
Mesh Pad	Vertical	10 – 12
Woven Pad	Vertical	8 – 15
Tube Bank	Horizontal	18 – 23
Tube Bank	Vertical	12 – 16

8 - 43

### Example 12-4

8 - 44

Estimate the gas velocity through a mist eliminator having a diameter of 6.5 feet, an average gas flow rate of 4,000 dscfm, and a peak gas flow rate of 4,760 dscfm. The peak gas stream temperature is 130°F, the static pressure during peak flow in the vessel is -30 in. WC, and the barometric pressure is 29.4 in. Hg. The moisture content of the gas stream is 6% by volume.

**Solution:**

The gas velocity should be evaluated under peak flow conditions because this is the time when reentrainment is most probable.

Convert the gas flow rate to actual conditions:

$$\text{scfm} = \frac{\text{dscfm}}{\left(\frac{100 - \%H_2O}{100}\right)} = \frac{4,760 \text{ dscfm}}{\left(\frac{100 - 6}{100}\right)} = 5,064 \text{ scfm}$$

$$\text{Absolute pressure} = 29.4 \text{ in. Hg} + \left[-30 \text{ in. WC} \left(\frac{1 \text{ in. Hg}}{13.6 \text{ in. WC}}\right)\right] = 27.19 \text{ in. Hg}$$

$$\text{Absolute temperature} = 130^\circ\text{F} + 460^\circ = 590^\circ\text{R}$$

$$\text{acfm} = 5,064 \left(\frac{590^\circ\text{R}}{528^\circ\text{R}}\right) \left(\frac{29.92 \text{ in. Hg}}{27.19 \text{ in. Hg}}\right) = 6,227 \text{ acfm}$$

8 - 45

### Example 12 - 4 (cont.)

$$\text{Area} = \frac{\pi d^2}{4} = \frac{\pi(6.5 \text{ ft})^2}{4} = 33.2 \text{ ft}^2$$

$$\text{Velocity} = \frac{6,227 \frac{\text{ft}^3}{\text{min}} \left(\frac{\text{min}}{60 \text{ sec}}\right)}{33.2 \text{ ft}^2} = 3.13 \text{ ft/sec}$$

8 - 46

### Operating Principles

- Collection mechanisms
- Pressure drop
- Gas cooling
- Liquid recirculation
- Liquid-to-gas ratio
- Liquid purge rates
- Alkali addition
- Wastewater treatment
- Mist elimination
- Capabilities and limitations

8 - 47

### Applicability Limitations

- Particle size distribution
- Water availability
- Wastewater treatment
- Condensation plume

8 - 48



Wet Scrubber Systems

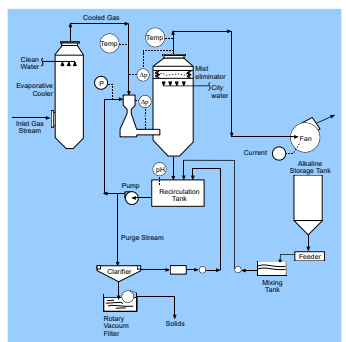

8 - 49

Scrubber Devices

- Spray tower scrubbers
- Packed bed scrubbers
- Ionizing wet scrubbers
- Fiber bed scrubbers
- Tray or plate scrubbers
- Condensation growth scrubbers
- Venturi scrubbers
- Collision scrubbers
- Ejector scrubbers

8 - 51



Spray Tower

8 - 52

Packed Bed



8 - 55

Horizontal Packed Bed

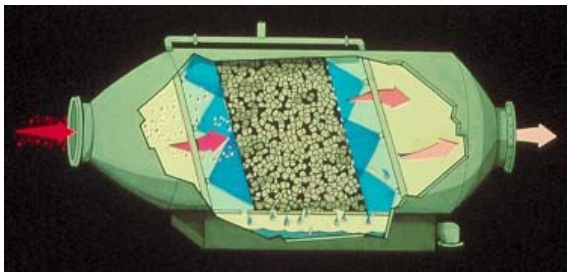

8 - 56



8 - 57

**Ionizing Wet Scrubber**

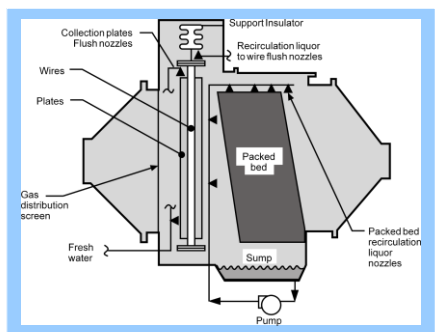

8 - 58

**Tri-Mer® Wet Scrubber**

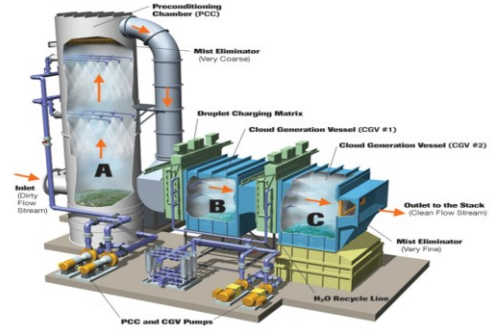

Cloud Chamber Wet Scrubber ([tri-mer.com](http://tri-mer.com))

8 - 59

**Fiber Bed Scrubber**

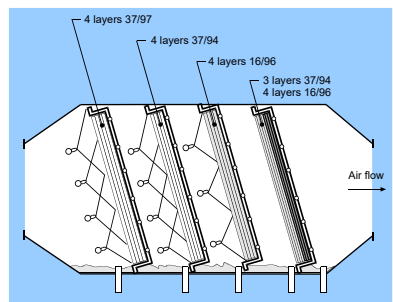

8 - 60

**Tray Scrubber**

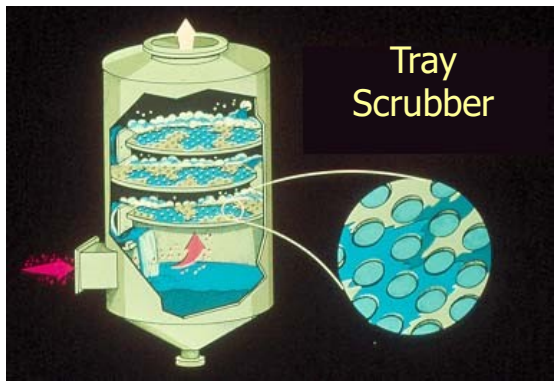

8 - 62

**Tray Types**

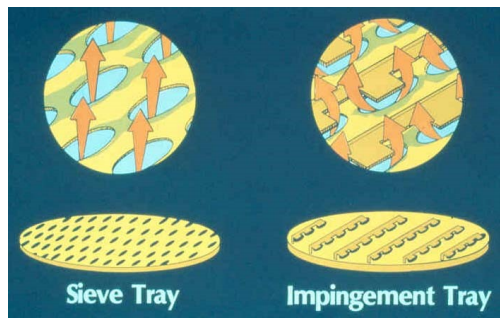

8 - 63

**Tray Types**

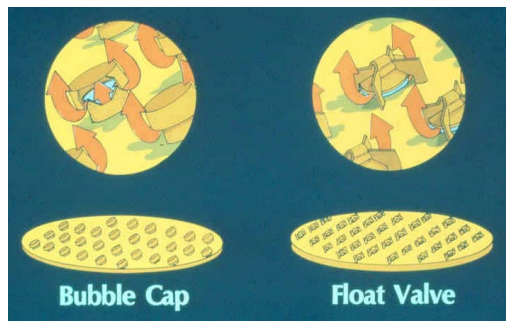

8 - 64

### Condensation Growth Scrubber

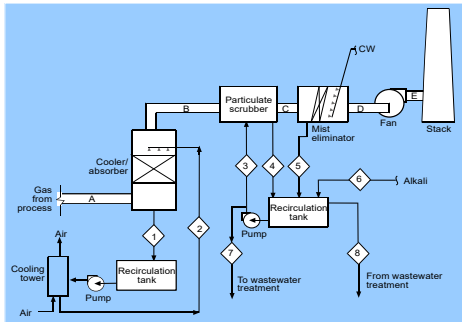

8 - 66

### Venturi Scrubber

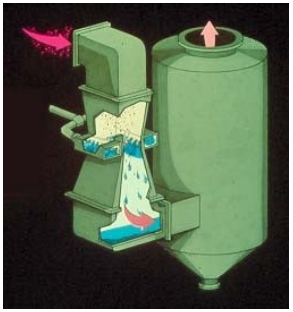

8 - 67

### Venturi Scrubber at a Mineral Plant



8 - 68

### Adjustable Throat Venturi Rectangular

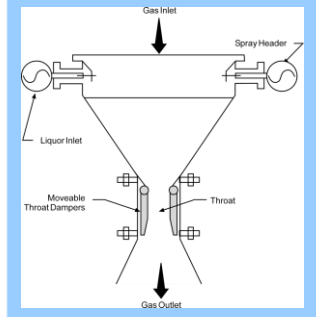

8 - 69

### Venturi Scrubber with Adjustable Throat

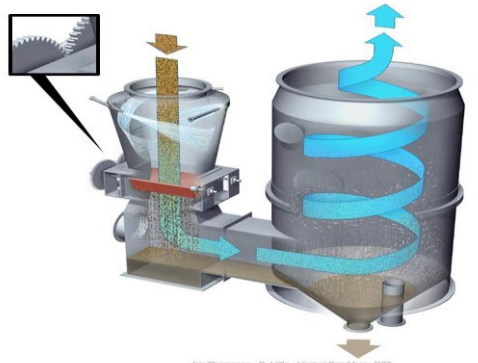

Jim Thompson - B. Little - Venturi Scrubber - D23

8 - 70

### Adjustable Throat Venturi Circular

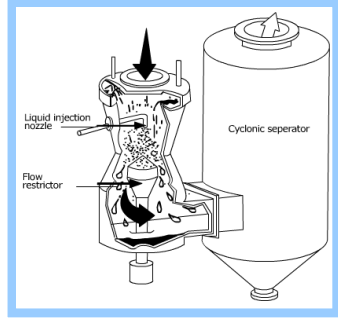

8 - 71

**Collision Scrubber**

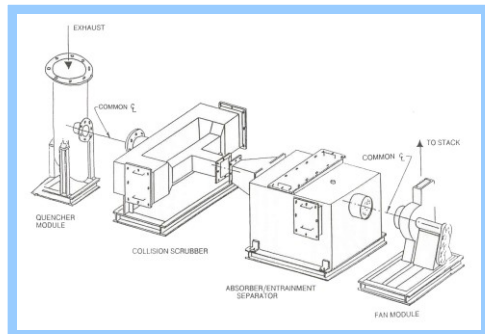

8 - 73

**Ejector Scrubber**

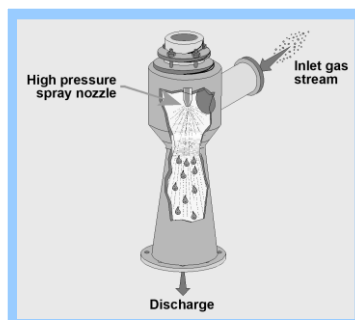

8 - 74

**Performance Evaluation**

- Empirical evaluation
- Pilot scale tests
- Mathematical models
- Instrumentation

8 - 75

**Empirical Evaluation**

- Average and maximum gas flow rates
- Average and maximum gas temperatures
- Concentrations of corrosive materials
- Concentrations of explosive materials
- Available of make-up water
- Liquid treatment and disposal requirements
- Process type, raw materials and fuels
- Source operating schedule
- Available area for scrubber system
- Alkali supply requirements
- Particle size distribution
- Emission test data

8 - 76

**Performance Evaluation**

- Empirical evaluation
- Mathematical models
- Instrumentation

8 - 77

**Mathematical Models**

- Counter-current spray tower scrubber
- Packed bed scrubber
- Tray scrubber
- Venturi scrubber
  - Johnstone model
  - Calvert model

8 - 78

### Counter-Current Spray Tower

$$\eta_i = 1 - e^{-\left[\frac{1.5v_t\eta_I z}{d_d(v_t - v_g)}\right]\left(\frac{L}{G}\right)}$$

Where:

- $\eta_i$  = collection efficiency for particle size  $i$
- $v_t$  = droplet terminal settling velocity (cm/sec)
- $\eta_I$  = single droplet collection efficiency (dimensionless)
- $z$  = scrubber height (cm)
- $d_d$  = droplet diameter (cm)
- $v_g$  = gas velocity (cm/sec)
- $L/G$  = liquid to gas ratio (dimensionless)

8 - 79

### Single-Droplet Collection Efficiency

$$\eta_I = \left(\frac{\Psi_I}{\Psi_I + 0.35}\right)^2$$

$$\Psi_I = \frac{C_c d_p^2 \rho_p V_r}{18\mu_g d_d}$$

where:

- $\Psi_I$  = inertial impaction parameter (dimensionless)
- $C_c$  = Cunningham slip correction factor (dimensionless)
- $d_p$  = physical particle diameter (cm)
- $\rho_p$  = particle density (gm/cm<sup>3</sup>)
- $V_r$  = relative velocity between particle and droplet (cm/sec)
- $d_d$  = droplet diameter (cm)
- $\mu_g$  = gas viscosity (gm/cm sec)

8 - 80



### Example 12-5

8 - 82

Estimate the collection efficiency of 4 μm diameter particles with a density of 1.1 g/cm<sup>3</sup> in a counter-current spray tower 3 meters high. The gas flow rate is 140 m<sup>3</sup>/min at 20°C, the water flow rate is 115 l/min, and the gas velocity is 100 cm/sec. The mean droplet diameter is 500 μm, and the droplet terminal settling velocity is 200 cm/sec. Assume a Cunningham correction of 1.0.

**Solution:**

Calculate the inertial impaction parameter:

$$\Psi_I = \frac{C_c d_p^2 \rho_p V_r}{18\mu_g d_d}$$

$$= \frac{(1.0)(4 \times 10^{-4} \text{ cm})^2 \left(1.1 \frac{\text{g}}{\text{cm}^3}\right) \left(200 \frac{\text{cm}}{\text{sec}} - 100 \frac{\text{cm}}{\text{sec}}\right)}{18 \left(1.8 \times 10^{-4} \frac{\text{g}}{\text{cm} \cdot \text{sec}}\right) (500 \times 10^{-4} \text{ cm})} = 0.109$$

8 - 83

### Example 12-5 (cont.)

Calculate the single droplet collection efficiency:

$$\eta_I = \left(\frac{\Psi_I}{\Psi_I + 0.35}\right)^2$$

$$= \left(\frac{0.109}{0.109 + 0.35}\right)^2 = 0.056$$

Calculate the particle collection efficiency:

$$\eta_i = 1 - e^{-\left[\frac{1.5v_t\eta_I z}{d_d(v_t - v_g)}\right]\left(\frac{L}{G}\right)}$$

$$= 1 - e^{-\left[\frac{1.5 \left(200 \frac{\text{cm}}{\text{sec}}\right) (0.056) (300 \text{ cm})}{\left(500 \times 10^{-4} \text{ cm}\right) \left(200 \frac{\text{cm}}{\text{sec}} - 100 \frac{\text{cm}}{\text{sec}}\right)}\right] \left[\frac{\left(115 \frac{\text{l}}{\text{min}}\right) \left(1 \times 10^{-3} \frac{\text{m}^3}{\text{l}}\right)}{140 \frac{\text{m}^3}{\text{min}}}\right]} = 0.563 = 56.3\%$$

8 - 84

### Packed Bed

$$\eta_i = 1 - e^{-\left[ \frac{\pi z \Psi_i}{(j+j^2)(\epsilon-Hd)d_c} \right]}$$

Where:

- $\eta_i$  = collection efficiency for particle size i
- $z$  = scrubber height (cm)
- $\Psi_i$  = inertial impaction parameter (dimensionless)
- $j$  = channel width as fraction of packing diameter (dimensionless)
- $\epsilon$  = bed porosity (dimensionless)
- $Hd$  = liquid holdup (dimensionless)
- $d_c$  = packing diameter (cm)

8 - 85

### Example 12-6

8 - 86

Estimate the collection efficiency of 4  $\mu\text{m}$  diameter particles with a density of 1.1  $\text{g}/\text{cm}^3$  in a 3 meter deep packed bed containing 5 cm diameter Raschig rings. The gas flow rate is 140  $\text{m}^3/\text{min}$  at 20°C, the water flow rate is 115 l/min, and the gas velocity is 100  $\text{cm}/\text{sec}$ . Assume  $j = 0.165$ ,  $\epsilon = 0.75$ , and  $Hd = 0$ , and a Cunningham correction of 1.0.

**Solution:**

Calculate the inertial impaction parameter:

$$\Psi_i = \frac{C_c d_p^2 \rho_p V_f}{18 \mu_g d_c}$$

8 - 87

### Example 12-6

$$= \frac{(1.0)(4 \times 10^{-4} \text{ cm})^2 \left( 1.1 \frac{\text{g}}{\text{cm}^3} \right) \left( 100 \frac{\text{cm}}{\text{sec}} \right)}{18 \left( 1.8 \times 10^{-4} \frac{\text{g}}{\text{cm} \cdot \text{sec}} \right) (5.0 \text{ cm})} = 1.09 \times 10^{-3}$$

Calculate the particle collection efficiency:

$$\eta_i = 1 - e^{-\left[ \frac{\pi z \Psi_i}{(j+j^2)(\epsilon-Hd)d_c} \right]}$$

$$= 1 - e^{-\left[ \frac{\pi(300 \text{ cm})(1.09 \times 10^{-3})}{[0.165+(0.165)^2][0.75-0](5.0 \text{ cm})} \right]} = 0.759 = 75.9\%$$

8 - 88

### Tray Scrubber

$$\eta_i = 1 - \left[ e^{-80F^2 \Psi_i} \right]^n$$

Where:

- $\eta_i$  = collection efficiency for particle size i
- $F$  = foam density fraction (dimensionless)
- $\Psi_i$  = inertial impaction parameter (dimensionless)
- $n$  = number of trays (dimensionless)

8 - 89

### Example 12-7

8 - 90

Estimate the collection efficiency of 4 μm diameter particles with a density of 1.1 g/cm<sup>3</sup> in a tray scrubber having 3 trays with 10 mm diameter holes. The gas flow rate is 140 m<sup>3</sup>/min at 20°C, the water flow rate is 115 l/min, and the gas velocity through the holes is 1,800 cm/sec. Assume F = 0.50 and a Cunningham correction of 1.0.

**Solution:**

Calculate the inertial impaction parameter:

8 - 91

### Example 12-7

$$\Psi_1 = \frac{C_c d_p^2 \rho_p V_T}{18 \mu_g d_c}$$

$$= \frac{(1.0)(4 \times 10^{-4} \text{ cm})^2 \left(1.1 \frac{\text{g}}{\text{cm}^3}\right) \left(1,800 \frac{\text{cm}}{\text{sec}}\right)}{18 \left(1.8 \times 10^{-4} \frac{\text{g}}{\text{cm} \cdot \text{sec}}\right) (1.0 \text{ cm})} = 0.098$$

Calculate the particle collection efficiency:

$$\eta_i = 1 - \left[ e^{-80F^2 \Psi_1} \right]^n$$

$$= 1 - \left[ e^{-80(0.50)^2 (0.098)} \right]^3 = 0.997 = 99.7\%$$

8 - 92

### Johnstone Venturi Scrubber Model

$$\eta_i = 1 - e^{-k \sqrt{\Psi_1} \frac{Q_l}{Q_g}}$$

**Where:**

- $\eta_i$  = collection efficiency for particle size i
- k = constant (1,000 ft<sup>3</sup>/gal)
- $\Psi_1$  = inertial impaction parameter (dimensionless)
- $Q_l/Q_g$  = liquid to gas ratio (gal/1,000 ft<sup>3</sup>)

8 - 93

### Droplet Diameter

$$d_d = \frac{16,400}{v_g} + 1.45 \left( \frac{Q_l}{Q_g} \right)^{1.5}$$

**Where:**

- $d_d$  = mean droplet diameter (micrometers)
- $v_g$  = gas velocity (ft/sec)
- $Q_l/Q_g$  = liquid to gas ratio (gal/1,000 ft<sup>3</sup>)

8 - 94

### Example 12-8

8 - 95

Estimate the collection efficiency of a 1 μm diameter particle with a density of 1.5 g/cm<sup>3</sup> in a venturi scrubber having a throat gas velocity of 300 ft/sec and a liquid to gas ratio of 8.0 gal/1,000 ft<sup>3</sup>. Assume a temperature of 68°F and a k of 0.15 1,000 ft<sup>3</sup>/gal.

**Solution:**

Calculate the mean droplet diameter:

$$d_d = \frac{16,400}{v_g} + 1.45 \left( \frac{Q_l}{Q_g} \right)^{1.5}$$

$$= \frac{16,400}{300} + 1.45(8.0)^{1.5} = 87.5 \mu\text{m}$$

Calculate the Cunningham correction factor:

$$C_c = 1 + \frac{6.21 \times 10^{-4} T}{d_p} = 1 + \frac{6.21 \times 10^{-4} (293 \text{ K})}{1 \mu\text{m}} = 1.18$$

8 - 96

**Example 12-8**

Calculate the inertial impaction parameter:

$$\Psi_I = \frac{C_c d_p^2 v_f V_f}{18 \mu_g d_d}$$

$$= \frac{(1.18)(1 \times 10^{-4} \text{ cm})^2 \left(1.5 \frac{\text{g}}{\text{cm}^3}\right) \left(300 \frac{\text{ft}}{\text{sec}} \times 30.48 \frac{\text{cm}}{\text{ft}}\right)}{18 \left(1.8 \times 10^{-4} \frac{\text{g}}{\text{cm} \cdot \text{sec}}\right) (87.5 \times 10^{-4} \text{ cm})} = 5.709$$

Calculate the particle collection efficiency:

$$\eta_i = 1 - e^{-k \sqrt{\Psi_i} \frac{Q_i}{Q_g}}$$

$$= 1 - e^{-0.15 \frac{1,000 \text{ ft}^3}{\text{gal}} \sqrt{5.709} \left(8.0 \frac{\text{gal}}{1,000 \text{ ft}^3}\right)} = 0.943 = 94.3\%$$

8 - 97

**Calvert Venturi Scrubber Model**

$$\ln P_i(d_p) = -B \frac{4K_{po} + 4.2 - 5.02K_{po}^{0.5} \left(1 + \frac{0.7}{K_{po}}\right) \tan^{-1} \sqrt{\frac{K_{po}}{0.7}}}{K_{po} + 0.7}$$

where  $P_i(d_p)$  = penetration for particle size  $i$   
 $B$  = parameter defined below  
 $K_{po}$  = impaction parameter at throat entrance, dimensionless

$$B = \left(\frac{L}{G}\right) \frac{\rho_l}{\rho_g C_D} \quad K_{po} = \frac{d^2 v_{gt} C_c \rho_p}{9 \mu_g d_d}$$

where  
 $L/G$  = liquid to gas ratio, dimensionless  
 $\rho_l, \rho_g$  = liquid and gas density,  $\text{kg/m}^3$   
 $C_D$  = drag coefficient (liquid at the throat)  
 $d$  = particle physical diameter, cm  
 $v_{gt}$  = gas velocity in throat, cm/sec  
 $\mu_g$  = gas viscosity, gm/cm-sec  
 $d_d$  = droplet diameter, cm  
 $C_c$  = Cunningham slip corr. factor  
 $\rho_p$  = particle density ( $\text{gm/cm}^3$ )

8 - 98

**Instrumentation**

- The types of instruments that are necessary for a particulate matter wet scrubber system depend, in part, on the size of the unit, the toxicity of the pollutants being collected, the variability of operating conditions, and the susceptibility to performance problems. Instruments in particulate matter wet scrubber systems usually include one or more of the following monitors.
  - Scrubber vessel static pressure drop
  - Mist eliminator static pressure drop
  - Inlet and outlet gas temperature
  - Recirculation liquid flow rate
  - Recirculation liquid pH
- 8 - 99

An equation for estimating the collection efficiency of a single size particle has been developed by Calvert et al for counter-current spray tower scrubbers:

$$\eta_i = 1 - e^{-\left[\frac{1.5 v_t \eta_i z}{d_d (v_t - v_g)}\right] \left(\frac{L}{G}\right)}$$

8 - 100

- Where:
  - $\eta_i$  = collection efficiency for particle size  $i$
  - $v_t$  = droplet terminal settling velocity (cm/sec)
  - $\eta_i$  = single droplet collection efficiency due to impaction (dimensionless)
  - $z$  = scrubber height (cm)
  - $d_d$  = droplet diameter (cm)
  - $v_g$  = gas velocity (cm/sec)
  - $L/G$  = liquid to gas ratio (dimensionless; i.e., liters/min per liters/min)
- 8 - 101





### Example Problem

- Estimate the liquid purge rate and recirculation pump flow rate for a scrubber system treating a gas stream of 30,000 acfm (inlet flow) with a particulate matter loading of 0.8 grains per acf. Assume that the scrubber particulate matter removal efficiency is 95% and the maximum suspended solids level desirable in the scrubber is 2% by weight. Use a liquid-to-gas ratio of 8 gallons (inlet) per thousand acf (outlet) and an outlet gas flow rate of 23,000 acfm.

8 - 103

### Solution

Calculate the inlet particulate mass:

$$\text{Inlet mass} = 30,000 \frac{\text{ft}^3}{\text{min}} \left( \frac{0.8 \text{ grains}}{\text{ft}^3} \right) \left( \frac{\text{lb}}{7,000 \text{ grains}} \right) = 3.43 \frac{\text{lb}}{\text{min}}$$

$$\text{Collected mass} = 0.95 (\text{Inlet mass}) = 3.26 \frac{\text{lb}}{\text{min}}$$

Purge solids of 3.26 lb/min are 2% of the total purge stream, therefore:

$$\text{Purge stream} = \frac{3.26 \frac{\text{lb}}{\text{min}}}{0.02} = 163.0 \frac{\text{lb}}{\text{min}}$$

A stream with 2% suspended solids has a specific gravity of about 1.02, therefore:

$$\text{Purge stream density} = \left( 8.34 \frac{\text{lb water}}{\text{gal}} \right) (1.02) = 8.51 \frac{\text{lb}}{\text{gal}}$$

$$\text{Purge stream flow rate} = \frac{163.0 \frac{\text{lb}}{\text{min}}}{8.51 \frac{\text{lb}}{\text{gal}}} = 19.2 \frac{\text{gal}}{\text{min}}$$

$$\text{Inlet liquid flow rate} = \left( 23,000 \frac{\text{ft}^3}{\text{min}} \right) \left( 8 \frac{\text{gal}}{1,000 \text{ ft}^3} \right) = 184.0 \frac{\text{gal}}{\text{min}}$$

$$\text{Pump flow rate} = 184.0 \frac{\text{gal}}{\text{min}} + 19.2 \frac{\text{gal}}{\text{min}} = 203.2 \frac{\text{gal}}{\text{min}}$$

8 - 104

### Example Problem

- Estimate the collection efficiency of 4 μm diameter particles with a density of 1.1 g/cm<sup>3</sup> in a counter-current spray tower 3 meters high. The gas flow rate is 140 m<sup>3</sup>/min at 20°C, the water flow rate is 115 l/min, and the gas velocity is 100 cm/sec. The mean droplet diameter is 500 μm, and the droplet terminal settling velocity is 200 cm/sec. Assume a Cunningham correction of 1.0.

8 - 105

### Solution

Calculate the inertial impaction parameter:

$$\Psi_1 = \frac{(1.0)(4 \times 10^{-4} \text{ cm})^2 \left( 1.1 \frac{\text{g}}{\text{cm}^3} \right) \left( 200 \frac{\text{cm}}{\text{sec}} - 100 \frac{\text{cm}}{\text{sec}} \right)}{18 \left( 1.8 \times 10^{-4} \frac{\text{g}}{\text{cm} \cdot \text{sec}} \right) \left( 500 \times 10^{-4} \text{ cm} \right)} = 0.109$$

Calculate the single droplet collection efficiency:

$$\eta_1 = \left( \frac{0.109}{0.109 + 0.35} \right)^2 = 0.056$$

Calculate the particle collection efficiency:

$$\eta = 1 - e^{- \left[ \frac{1.5 \left( 200 \frac{\text{cm}}{\text{sec}} \right) (0.056) (300 \text{ cm})}{\left( 500 \times 10^{-4} \text{ cm} \right) \left( 200 \frac{\text{cm}}{\text{sec}} - 100 \frac{\text{cm}}{\text{sec}} \right)} \right] \left[ \frac{\left( 115 \frac{\text{l}}{\text{min}} \right) \left( 1 \times 10^{-3} \frac{\text{m}^3}{\text{min}} \right)}{140 \frac{\text{m}^3}{\text{min}}} \right]} = 0.563 = 56.3\%$$

8 - 106

### Venturi scrubbers Particle Collection Equation

$$\eta_i = 1 - e^{-k \sqrt{\Psi_1} \frac{Q_l}{Q_g}}$$

Where:

- $\eta_i$  = collection efficiency for particle size  $i$
- $k$  = constant (1,000 ft<sup>3</sup>/gal)
- $\Psi_1$  = inertial impaction parameter (dimensionless)
- $Q_l/Q_g$  = liquid to gas ratio (gal/1,000 ft<sup>3</sup>)

8 - 107

The Sauter mean diameter is the diameter of a drop having the same volume/surface area ratio as the entire distribution. For an air-water system, this droplet diameter is given by:

$$d_d = \frac{16,400}{v_g} + 1.45 \left( \frac{Q_l}{Q_g} \right)^{1.5}$$

Where:

- $d_d$  = mean droplet diameter (micrometers)
- $v_g$  = gas velocity (ft/sec)
- $Q_l/Q_g$  = liquid to gas ratio (gal/1,000 ft<sup>3</sup>)

8 - 108

Example Problem

- Estimate the collection efficiency of a 1 μm diameter particle with a density of 1.5 g/cm<sup>3</sup> in a venturi scrubber having a throat gas velocity of 300 ft/sec and a liquid to gas ratio of 8.0 gal/1,000 ft<sup>3</sup>. Assume a temperature of 68°F, a k of 0.15 and 1,000 ft<sup>3</sup>/gal.

8 - 109

Solution

Calculate the mean droplet diameter:

$$d_d = \frac{16,400}{300} + 1.45(8.0)^{1.5} = 87.5 \mu\text{m}$$

Calculate the Cunningham correction factor:

$$C_c = 1 + \frac{6.21 \times 10^{-4} T}{d_p} = 1 + \frac{6.21 \times 10^{-4} (293 \text{ K})}{1 \mu\text{m}} = 1.18$$

Calculate the inertial impaction parameter:

$$\Psi_1 = \frac{(1.18)(1 \times 10^{-4} \text{ cm})^2 \left(1.5 \frac{\text{g}}{\text{cm}^3}\right) \left(300 \frac{\text{ft}}{\text{sec}} \times 30.48 \frac{\text{cm}}{\text{ft}}\right)}{18 \left(1.8 \times 10^{-4} \frac{\text{g}}{\text{cm} \cdot \text{sec}}\right) (87.5 \times 10^{-4} \text{ cm})} = 5.709$$

Calculate the particle collection efficiency:

$$\eta_1 = 1 - e^{-0.15 \frac{1,000 \text{ ft}^3}{\text{gal}} \sqrt{5.709} \left(8.0 \frac{\text{gal}}{1,000 \text{ ft}^3}\right)} = 0.943 = 94.3\%$$

8 - 110

Conventional APC Devices

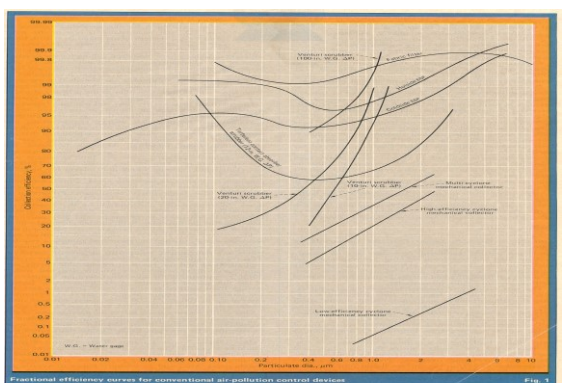

8 - 111

Novel Control Devices

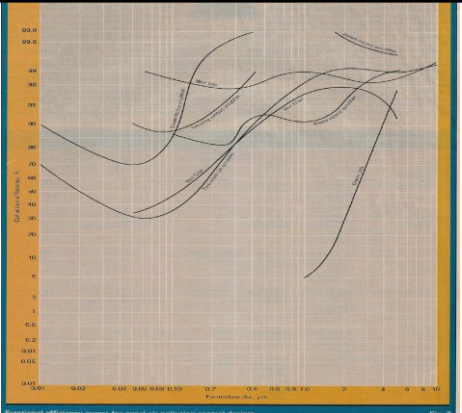

8 - 112

Chapter 9

Electrostatic Precipitators

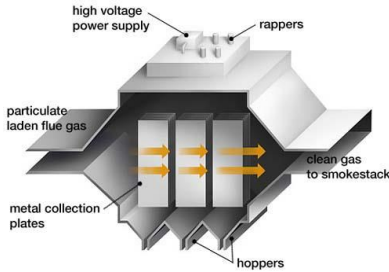

9 - 1

History of ESPs

- 1907: The first ESP developed for acid mist control on a Sulfuric Acid plant in California
  - Small ESP only 100 to 200 ACFM
- By 1917, several other ESPs installed for cement kiln dust, lead smelter fumes, etc.
  - Air flows up to 300,000 ACFM
- 1923: First ESP on a coal-fired power plant
  - 90% collection efficiency
- By 1940, efficiencies were near 95%
- By the 1950s, efficiencies were near 98%
- By mid 1970s, efficiencies were near 99.5%
- Today, efficiencies are greater than 99.9%

Conventional ESP

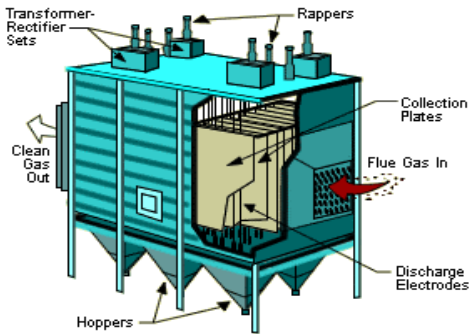

Three Basic Steps to Particulate Matter Collection in an ESP

- **Step 1:** development of a high-voltage *direct current* that is used to *electrically charge particles* in the gas stream,
- **Step 2:** development of an *electric field* in the space between the discharge electrode and the positively charged collection electrode *that propels the negatively charged ions and particulate matter* toward the collection electrode, and
- **Step 3:** removal of the collected particulate by use of a rapping mechanism (or water flushing in the case of a wet collector).

Electrostatic Precipitation

- Particle Charging
- Particle Collecting
- Particle Removal

Precipitator Field Energization

The purpose of the high voltage equipment of an electrostatic precipitator is to cause particle charging and migration.

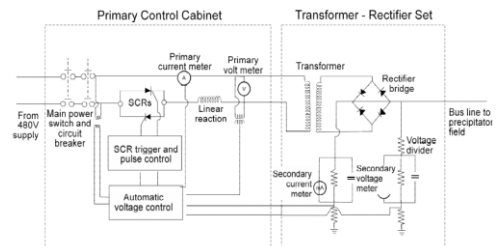

The *Transformer-Rectifier set* converts primary low-voltage alternating current to secondary high-voltage (of more than 50,000 volts) *direct current* and applied to the discharge electrodes.

9 - 6

### Voltage Limits Excessive Spark Rates

- ESP collection efficiency will increase with increase in applied field voltage.

$$\omega = \frac{neEC_c}{3\pi\mu_g d_p}$$

- Since sparking represents a breakdown in the electric field, the highest voltage that can be applied to any field is the voltage at which sparking occurs.

- When a spark occurs, the strength of the electric field strength is momentarily reduced.

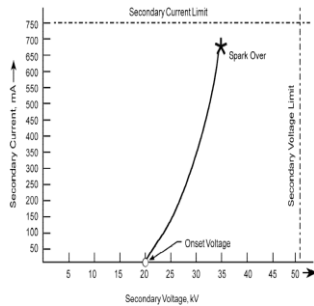

Sparks are surges of localized electric current between the discharge electrodes and the collection plate.

### Secondary Voltage Before And After A Spark

After each spark, the automatic voltage controller shuts off the primary voltage for a short period of time (milliseconds) to prevent a sustained, damaging power arc. Once this quench period is over, the voltage is ramped up quickly to a voltage very close to the previous point at which the spark occurred.

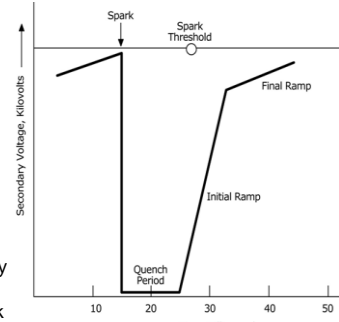

9 - 8

### Voltage Limits Excessive Spark Rates

- While excessive sparking reduces collection efficiency, some degree of sparking is necessary to ensure that the field is operating at the highest possible applied voltage.
- Average "spark over" rate for optimum performance is:
  - Inlet fields: 20 sparks/min.
  - Intermediate fields: 10 sparks/min.
  - Outlet fields: Zero or near zero sparks/min.

### Voltage Limits for Normal ESP Operation

- Note that the three operating curves are shifted to the right. In part, this is due to the higher resistivity of the fly ash layer.
- This effect is most pronounced in the first field, where dust concentration is the highest. It decreases as the dust concentration decreases.

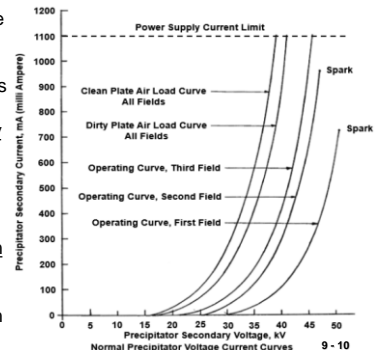

9 - 10

### Voltage Limits for Abnormal ESP Operation

- This figure illustrates abnormal voltage current (V-I) curves which are indicative of various precipitator problems.
- Curve (1) illustrates a resistance path to ground. It might represent a dirty / cracked insulator or a high hopper ash level.
- Curve (2) illustrates severe misalignment between emitting electrodes and collecting plates.
- Curve (3) illustrates high resistivity and severe back corona.
- Curve (4) illustrates high resistivity and moderate back corona.
- Curve (5) indicates high resistivity with near normal operation.
- Curve (6) illustrates the effect of heavy dust deposits on the emitting electrodes.

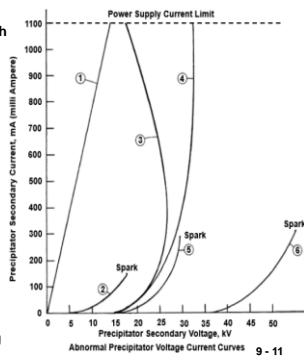

9 - 11

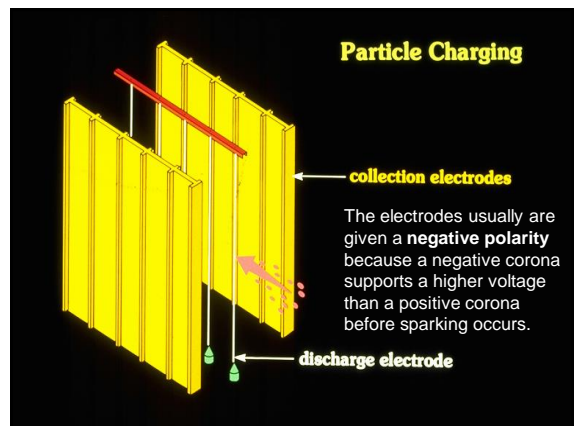

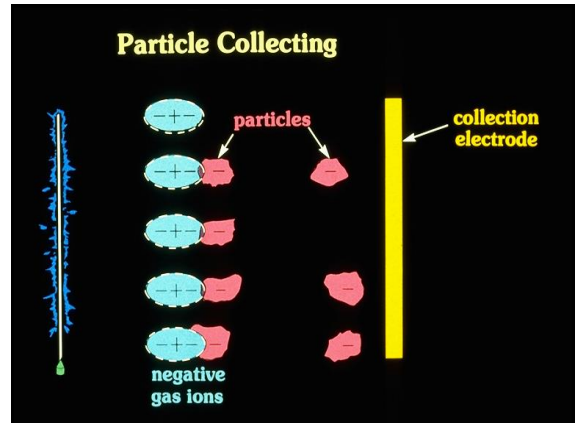
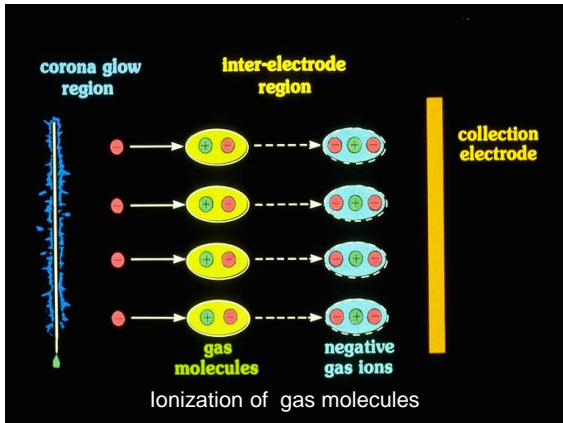
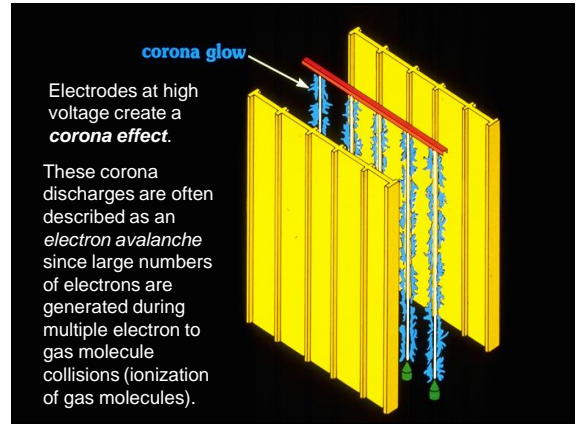
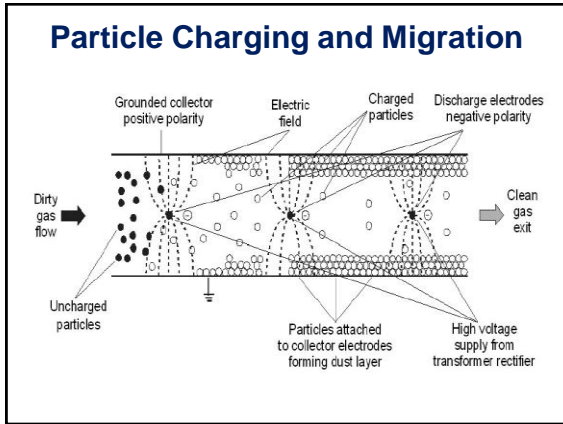

### Field Charging

- in **field charging**, particles cause a local dislocation of the electric field as they enter the field.
- The **negative gas ions traveling along the electric field lines collide with the particles** and impart a charge to them [as shown at (a)].
- The **ions continue to collide a particle** until the charge on that particle is sufficient to **divert the electric lines away from it** [as shown at (b)]. This prevents new ions from colliding with the charged dust particle.
- When a particle no longer receives an ion charge (it is said to be **saturated**), the charged particles then migrate towards the collection electrode and are collected.

(a) Field lines distorted by particle      (b) Saturated particle migrates toward collection electrode

Field Charging      9 - 17

### Diffusional Charging

- Unlike field charging, **diffusional charging** occurs when **negative gas ions collide with the submicron particles** because of their random motion and **impart a charge on the particles**.
  - Submicron-sized particles charge more slowly but, once charged, move rapidly to the collection plate.
  - Because of **smaller drag forces**, which depend on the particle diameter, **submicron particles are deposited near the inlet** and larger particles are deposited farther into the precipitator.
- Large particles** accumulate higher electrical charges (because of large surface area) and, therefore, **are more strongly affected by the applied electrical field** than submicron particles.

9 - 18

### Particle Collection

The particles are held on to the collection plate by the charge difference between the particle & the plate. The electrons that were initially on the particle find a path for reaching the plate. As the electrons flow off the particles, the force holding it to the plate becomes weak. This means that the dust layer can be easily dislodged.

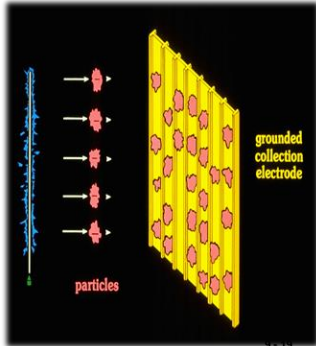

### Dust Layer Resistivity

- The ability of the electrical charges to move through the dust layer is measured in terms of dust layer resistivity.
- The dust layer resistivity is based on units of ohm-centimeters.
  - This is simply the ohms of resistance created by each centimeter of dust in the dust layer.
- High resistivity** is generally considered to be equal to or above  $10^{10}$  ohm-cm.
- Low resistivity** is generally considered to be equal to or below  $10^7$  ohm-cm.
- Moderate (or preferred) resistivity** is between  $10^7$  and  $10^{10}$  ohm-cm.

### Dust Layer Resistivity

- When the resistivity is **very low**, (dust layer is a good conductor) the electrostatic charge is drained off too quickly and the particles are re-entrained into the gas.
- When the resistivity is **very high** the dust layers are so strongly held by the electrostatic fields, it is hard to dislodge the dust.
  - The electrons have difficulty moving through the dust layer.
- When the resistivity is **normal**, particles will be easy to collect.

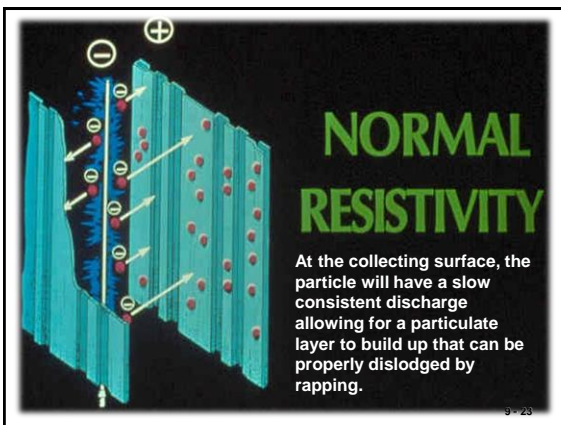
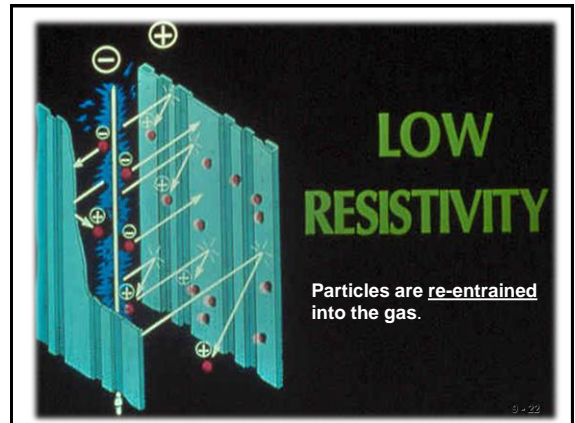

### More Adverse Impacts of High Resistivity

- As the dust layer builds up, the voltage difference between the discharge electrode and the dust layer decreases, reducing the electrostatic field strength used to drive the gas ion carrying particles over to the dust layer.
- Back corona (or reverse ionization):** This occurs when the electrostatic voltage across the dust layer is so great that corona discharges begin to appear in the gas trapped within the dust layer creating the formation of positive gas ions that stream toward the negatively charged discharge electrode. These positive ions neutralize some of the negatively charged particles waiting to be collected, thereby decreasing the precipitator's efficiency.

9 - 25

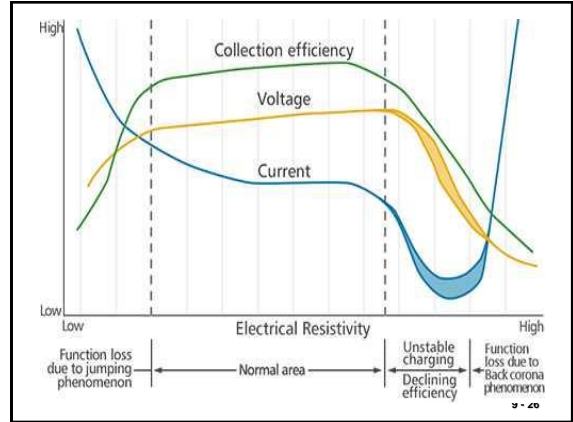

9 - 20

### Conditioning High Resistivity

- Moisture Conditioning:** Moisture reduces the resistivity of most dusts and fumes at temperatures below 250° to 300°F.
- Moisture conditioning is performed by steam injection, water sprays, or wetting the raw materials before they enter the ESP.

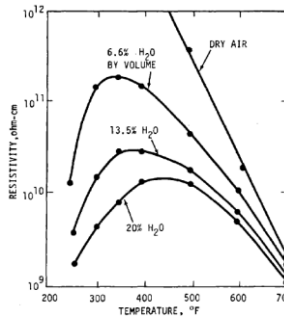

9 - 27

### Conditioning High Resistivity

#### Adjust temperature:

On the low temperature side of the typical resistivity curve, the resistivity can decrease dramatically as the gas temperature drops slightly. This is due to the increased adsorption of electrically conductive vapors present in the gas stream.

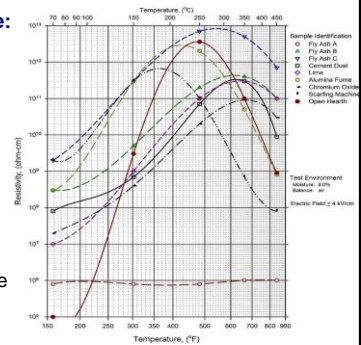

### Conductivity Paths

- Electrons pass directly through each particle until they reach the metal surface. This is called **bulk conduction**. A common electrical conductor for **bulk conduction** is **carbonaceous material**.
- Electrons can pass over the surfaces of various particles until they reach the metal surface. This is called **surface conduction** and occurs when vapor phase compounds that can conduct electricity adsorb onto the surfaces of the particles.

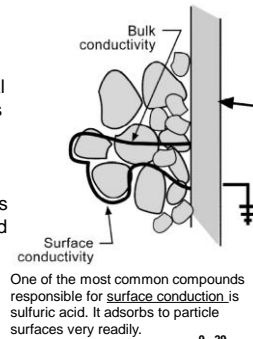

9 - 29

### Conductivity Path & Resistivity: Surface Conduction

- Surface conduction is controlled by the particle surface reactivity and gas components.** The resistivity decreases as the gas temperature drops. This is due to the increased adsorption of electrically conductive vapors present in the gas stream (i.e. sulfuric acid).

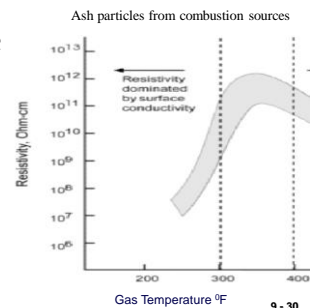

9 - 30

### Conditioning High Resistivity

Condition with additional substances (e.g. SO<sub>3</sub>, NH<sub>3</sub>, etc.)  
 The ability of sulfuric acid &/or ammonia to electrically condition the particle surfaces (nucleate the particle surface) is due to its hygroscopic tendencies and then form a conductive layer on the particle.

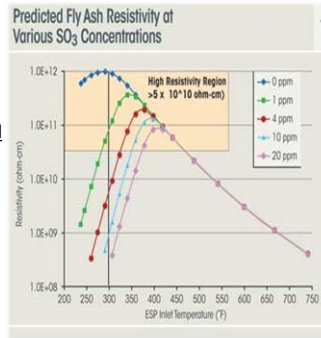

### Flue Gas Conditioning System

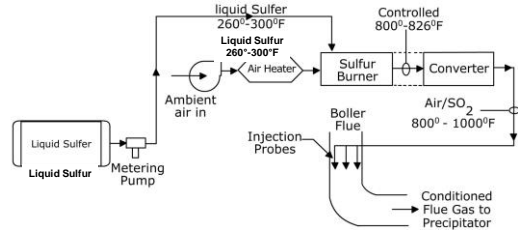

Flue gas conditioning (FGC) systems are used exclusively to adjust the resistivity conditions in cold side ESPs serving coal-fired boilers. Sulfur trioxide reacts to form sulfuric acid vapor and heterogeneously nucleates on the surfaces of particles to adjust the surface conductivity.

### Example of Sulfur Needed (Example 9-5 in Handbook)

A coal-fired utility boiler generates 5 ppm of sulfuric acid. Diagnostic tests have indicated that 17 ppm of sulfuric acid are needed in the gas stream to maintain the flyash resistivity in the moderate range. Calculate the sulfur required to operate a sulfur trioxide conditioning system for a period of one year. Assume that the boiler has a gas flow rate of  $1.0 \times 10^6$  ACFM, the gas temperature is 310°F, the boiler operates 82% of the year, and the sulfur trioxide system is needed 85% of the operating time.

**Solution:**

Sulfur Trioxide System Operating Hours:

$$\text{Operating hours} = 8,760 \text{ total hours} \left( \frac{0.82 \text{ boiler hours}}{\text{total hours}} \right) \left( \frac{0.85 \text{ FGC hours}}{\text{boiler hours}} \right) = 6,106 \text{ FGC hours}$$

### Example (cont.)

Sulfur Trioxide Demand:  $\text{ppm} = \text{mole (or volume) fraction of pollutant in mixture} \times 10^6$

$$\text{SO}_3 \text{ needed} = 17 \text{ ppm} - 5 \text{ ppm} = 12 \text{ ppm} = 1.2 \times 10^{-5} \text{ lb moles SO}_3/\text{lb mole flue gas}$$

Sulfur Trioxide Injection Requirements:  $\text{SCFM} = \text{ACFM} \left( \frac{T_{\text{Std}}}{T_{\text{Fact}}} \right) @ \text{ standard pressure}$

$$\text{SO}_3 \text{ needed} = \left( 1 \times 10^6 \frac{\text{ft}^3}{\text{min}} \right) \left( \frac{528^\circ\text{R}}{770^\circ\text{R}} \right) \left( \frac{\text{lb-mole}}{385.4 \text{ std ft}^3} \right) \left( \frac{\text{min}}{60 \text{ hr}} \right) \left( 1.2 \times 10^{-5} \frac{\text{lb-mole SO}_3}{\text{lb-mole}} \right) = 1.28 \text{ lb-moles/hr}$$

Sulfur Required:  $2\text{S} + 3\text{O}_2 \rightarrow 2\text{SO}_3$   
 Sulfur lb moles = SO<sub>3</sub> lb moles = 1.28 lb moles/hour

$$\text{Sulfur required} = \left( 1.28 \frac{\text{lb-moles}}{\text{hr}} \right) \left( \frac{6,106 \text{ hrs}}{\text{year}} \right) \left( \frac{32 \text{ lbs}}{\text{lb-mole}} \right) \left( \frac{\text{ton}}{2,000 \text{ lbs}} \right) = 125 \text{ tons/year}$$

### ESP Applicability Limitations

- Extremely low particle resistivity
- Potential fire and explosion hazards
  - Fires can occur in dust layers on the collection plates or in the accumulated solids in a hopper.
- Sticky particulate matter
  - Wet ESPs can operate very well with moderately sticky material. However, it must be possible to remove the contaminants either by normal drainage or by occasional cleaning sprays.
- Ozone formation

### Precipitator Systems

- There are three categories of ESPs.
  - Dry, negative corona:** this type is used on the largest systems and are the most common type of units in service.
  - Wet, negative corona:** use water on the collection plates to remove the collected solids.
    - 2 design types: (1) vertical flow and (2) horizontal flow
  - Wet, positive corona:** are sometimes termed *two-stage precipitators*. Particle charging occurs in a pre-ionizer section, and particle collection occurs in a downstream collection plate section.



### Two Stage ESP

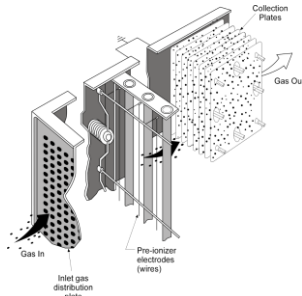

9 - 37

### Wet, Negative Corona ESP

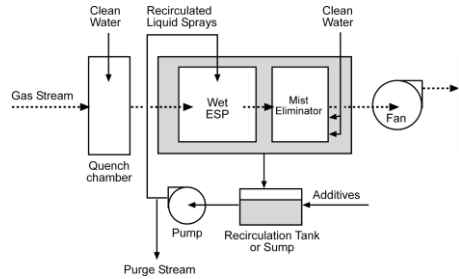

In wet ESP's, the collected particulate is removed by an intermittent or continuous stream of water or other conducting fluid that flows down over the collection electrodes and into a receiving sump. Some systems use a liquid recirculation system and liquid additives to maintain the proper pH in the collection plate sprays

9 - 38

### Horizontal Flow Wet, Negative Corona ESP

- Used where mists must be controlled or when solid PM has undesirable electrical or physical properties (these include stickiness or a high carbonaceous composition).
- A washing system, rather than rappers, is used for dust removal.
- Cleaning of the collection plates is performed by a set of overhead sprays on the inlet side of each field.

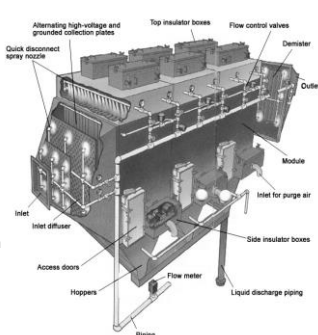

9 - 39

### Vertical Flow Wet, Negative Corona ESP

The gas stream enters the chamber at the top of the unit. High voltage discharge electrodes are mounted in the center of each tube to generate the negative corona. The charged particles migrate to the wet inner surface of the tube and are collected. Liquid moving down the tube surfaces carries the collected material to the wet ESP sump.

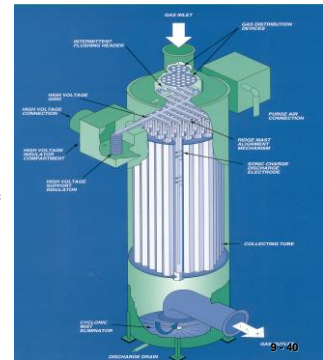

9 - 40

### Wet, Positive Corona, Two Stage ESP

- Used for the collection of organic droplets and mists from relatively small industrial applications.
- Electrical charges are applied to particles as they pass through the pre-ionizer section. These particles are then collected on the downstream collection plates.
- These ESPs only collect liquid particles that drain from the plates. The collection plates are designed to allow for easy removal and manual cleaning (on a weekly or monthly basis).

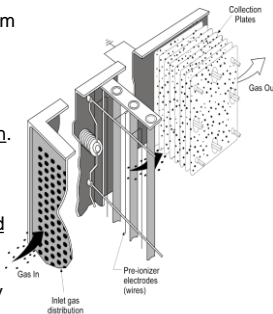

9 - 41

### Negative Corona, Single Stage, Dry ESP

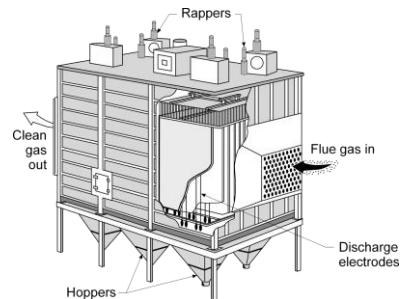

9 - 42

### Flow Distribution

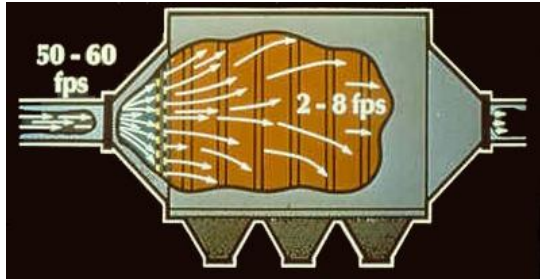

The gas stream passing through the duct toward the precipitator is moving too fast for effective treatment. Deceleration occurs by expanding the gas flow area in the inlet transition section immediately upstream of the precipitator. 9 - 43

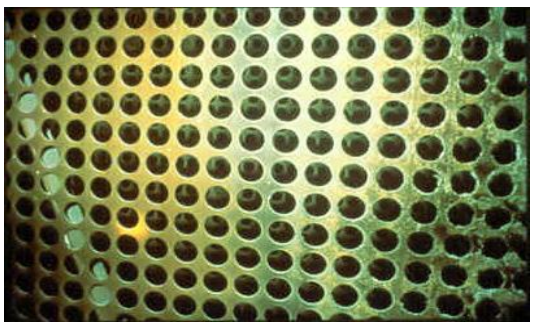

In addition to slowing down the gas stream, the inlet transition is used to distribute the gas flow as uniformly as possible so that there are no significant cross-sectional variations in the gas velocities at the entrance of the precipitator. 9 - 44

### Discharge Electrodes

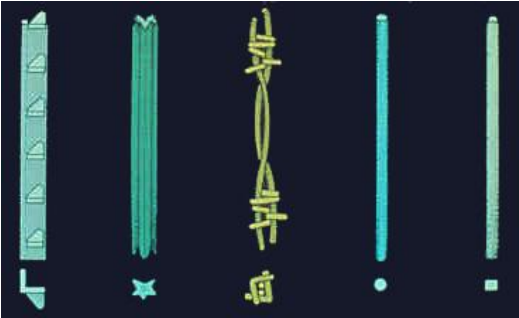

Note the indentations and sharp corners on some of the electrodes. These are designed to enhance the corona effect. 9 - 45

### Weights Attached to Discharge Electrodes

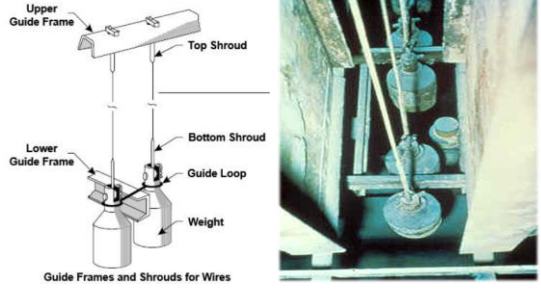

Movement of the wire-type discharge electrodes is minimized by hanging bottle weights on each wire. These provide 25 to 30 pounds of tension on the wire so that it does not move excessively. 9 - 46

### Collection Electrodes (plates)

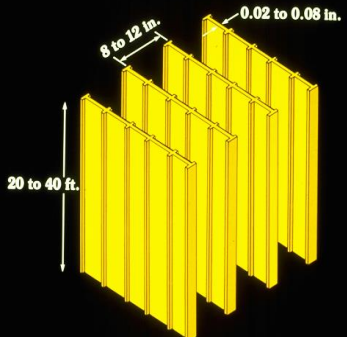

### Collection Plates

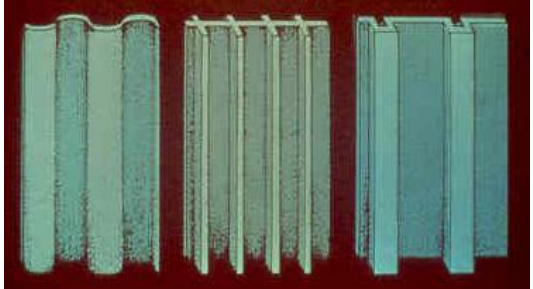

The baffles along the collecting plates are there to catch better the drifting particles. 9 - 48

### Rappers

- The rapping frequency is not constant throughout the precipitator.
  - The inlet fields should be rapped much more frequently, since they collect large quantities of particulate matter, than the middle & outlet fields.
    - Inlet field collection plates is usually once every 5 to 15 minutes.
    - Outlet fields collection plates is usually once every hour to once every 24 hours.
- There are **two basic types of rappers**:
  - (1) roof-mounted rappers and
  - (2) side-mounted rappers.

9 - 49

### Roof Mounted Rappers for Collection Plates



A current pulse raises the steel plunger inside the MIGI rapper then, by the effect of gravity, the plunger drops back and strikes a rod which is connect to many plates inside the ESP.

9 - 50

### Roof Mounted Rappers in Operation

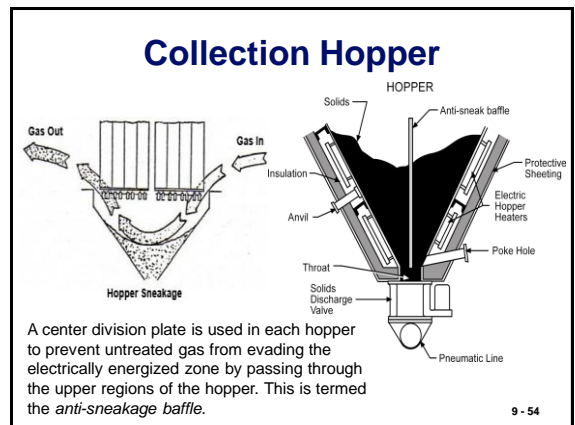
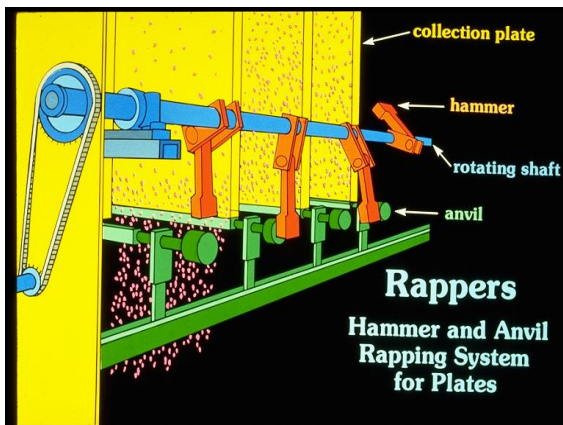
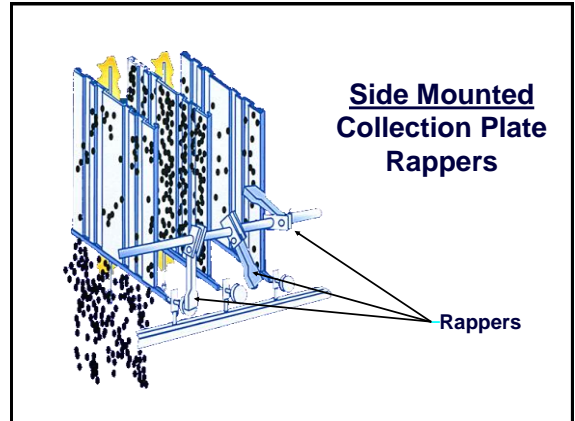
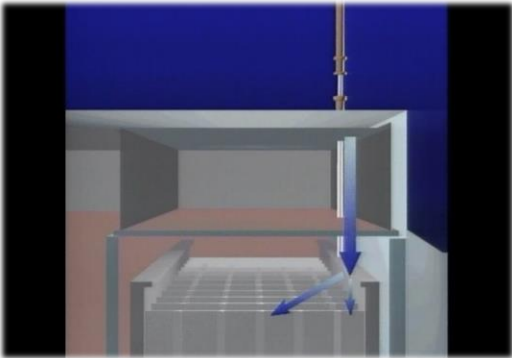

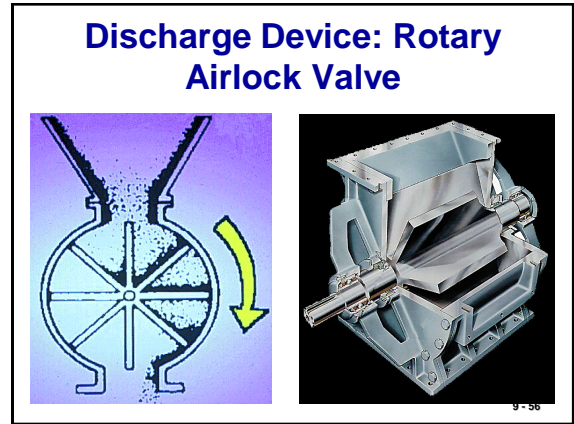
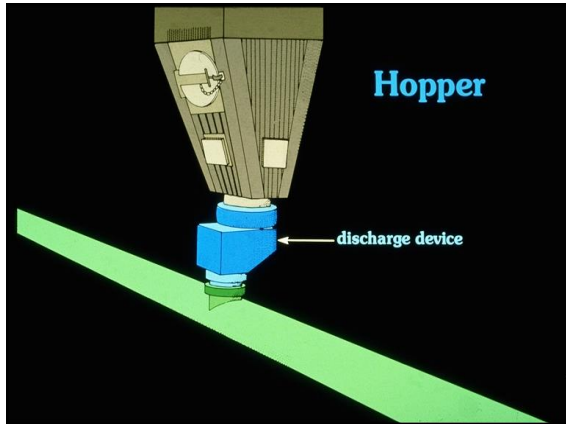

### ESP Fields

The discharge electrodes are divided into fields – each with their own separate power supply.

By sectionalizing the precipitator into separate fields, the problems associated with frequent sparking can be isolated to the first few fields with high spark rates.

Approximately 50-80% of the particulate is removed in each separate field. The inlet fields remove much greater quantities of dust than the outlet fields.

Each field acts as an independent precipitator

9 - 57

### Example

(Listed in Manual as Example 9-4)

Estimate the quantities of dust in each field of a four-field electrostatic precipitator having efficiencies of 80%, 75%, 70%, and 65% respectively. Assume a gas flow rate of 250,000 ACFM and a particulate matter loading of 2 grains per actual cubic foot. (7000 grains = 1 lb<sub>m</sub>)

Field	Assumed Efficiency	Particulate Entering (lb <sub>m</sub> /hr)	Particulate Leaving, (lb <sub>m</sub> /hr)	Particulate Collected (lb <sub>m</sub> /hr)
1 (inlet)	80	4,286	857	3,429
2 (middle)	75	857	214	643
3 (middle)	70	214	64	150
4 (outlet)	65	64	22	42

This example shows that large quantities of particulate are captured in the inlet field, and frequent rapping is needed.

9 - 58

### Solution

#### Field #1

Inlet = (2 grains/ft<sup>3</sup>)(1.0 lbm/7000 grains)(250,000 ft<sup>3</sup>/min)(60 min/hr) = 4,286 lbm/hr

Outlet = 4,286 (1 - 0.8) = 857 lbm/hr

Particles Collected = 4,286 - 857 = 3,429 lbm/hr

#### Field #2

Inlet = 857 lbm/hr

Outlet = 857 (1 - 0.75) = 214 lbm/hr

Particles Collected = 857 - 214 = 643 lbm/hr

9 - 59

### Example 9-2

One electrostatic precipitator serving a coal-fired boiler has a gas stream of 500,000 ACFM, an inlet particulate mass concentration of 2 grains per ACF, and an SCA of 300 ft<sup>2</sup>/1000 ACFM. What is the increase in the emission rate if one of the four fields trips offline due to an internal mechanical-electrical problem? Assume the inlet field has an efficiency of 80%, the two middle fields have an efficiency of 70%, and the outlet field has an efficiency of 60%.

A second electrostatic precipitator serving a similar coal-fired boiler also has a gas flow rate of 500,000 ACFM, an inlet particulate mass concentration of 2 grains per ACF, and an SCA of 300 ft<sup>2</sup>/1000 ACFM. However, this unit only has three fields in series. What is the increase in the emission rate when a field trips offline if the inlet field has an efficiency of 85%, the middle field has an efficiency of 81%, and the outlet field has an efficiency of 75%?

9 - 60

### Example 9-2 (cont.)

For the first precipitator, the efficiency of four fields in series during routine operation can be estimated as follows:

$$\text{Emissions}_{\text{Routine}} = \frac{2 \text{ grains}}{\text{ACF}} \left(1 - \frac{\text{eff}_1}{100}\right) \left(1 - \frac{\text{eff}_2}{100}\right) \left(1 - \frac{\text{eff}_3}{100}\right) \left(1 - \frac{\text{eff}_4}{100}\right)$$

$$\text{Emissions}_{\text{Routine}} = \frac{2 \text{ grains}}{\text{ACF}} \left(1 - \frac{80}{100}\right) \left(1 - \frac{70}{100}\right) \left(1 - \frac{70}{100}\right) \left(1 - \frac{60}{100}\right)$$

$$\text{Emissions}_{\text{Routine}} = \frac{2 \text{ grains}}{\text{ACF}} (0.20)(0.30)(0.30)(0.40) = 0.014 \text{ grains / ACF}$$

When one of the four fields is out of service, the performance of the precipitator can be calculated as follows:

$$\text{Emissions}_{\text{Upset}} = \frac{2 \text{ grains}}{\text{ACF}} \left(1 - \frac{\text{eff}_1}{100}\right) \left(1 - \frac{\text{eff}_2}{100}\right) \left(1 - \frac{\text{eff}_3}{100}\right) \left(1 - \frac{\text{eff}_4}{100}\right)$$

$$\text{Emissions}_{\text{Upset}} = \frac{2 \text{ grains}}{\text{ACF}} \left(1 - \frac{80}{100}\right) \left(1 - \frac{70}{100}\right) \left(1 - \frac{70}{100}\right) \left(1 - \frac{0}{100}\right)$$

9 - 61

### Example 9-2 (cont.)

$$\text{Emissions}_{\text{Upset}} = \frac{2 \text{ grains}}{\text{ACF}} (0.20)(0.30)(0.30)(1.0) = 0.036 \text{ grains / ACF}$$

In this case, the emissions increased from 0.014 to 0.036 grains/ACF.

In this general calculation approach, it is assumed that the outlet field, the one with the lowest efficiency, is not available. This is an appropriate calculation approach regardless of which of the four is tripped offline. The roles of the four fields in series will shift as soon as one is lost. For example, the second field becomes the first field if the inlet field trips offline. If one of the middle fields is lost, the gas stream entering the outlet field has high mass loadings and larger sized particulate than during routine operation. Accordingly, the outlet field operates at the efficiency of a middle field.

For the second precipitator, the efficiency during routine operation and during upset conditions after the loss of one of the fields is estimated as follows:

$$\text{Emissions}_{\text{Routine}} = \frac{2 \text{ grains}}{\text{ACF}} \left(1 - \frac{85}{100}\right) \left(1 - \frac{81}{100}\right) \left(1 - \frac{75}{100}\right)$$

$$\text{Emissions}_{\text{Routine}} = \frac{2 \text{ grains}}{\text{ACF}} (0.15)(0.19)(0.25) = 0.014 \text{ grains / ACF}$$

9 - 62

### Example 9-2 (cont.)

$$\text{Emissions}_{\text{Upset}} = \frac{2 \text{ grains}}{\text{ACF}} \left(1 - \frac{85}{100}\right) \left(1 - \frac{81}{100}\right) \left(1 - \frac{0}{100}\right)$$

$$\text{Emissions}_{\text{Upset}} = \frac{2 \text{ grains}}{\text{ACF}} (0.15)(0.19)(1.0) = 0.057 \text{ grains / ACF}$$

The second precipitator has an emission increase from 0.014 to 0.057 grains/ACF. This is a substantially higher increase than the first precipitator.

9 - 63

## Particle Collection

- **Collection efficiency** is the primary consideration of ESP design. The collection efficiency and/or the collection area of an ESP can be estimated using several equations.
- These equations give a theoretical estimate of the overall collection efficiency of the unit operating under ideal conditions. Unfortunately, a number of operating parameters can adversely affect the collection efficiency of the precipitator.

9 - 64

## Collection Efficiency

### Deutsch-Anderson Equation

$$\eta = 1 - e^{-\omega \frac{A}{Q}}$$

Where:

$\eta$  = efficiency (decimal form)

$\omega$  = migration velocity (ft/sec)

$A$  = total collection plate area (ft<sup>2</sup>)

$Q$  = total gas flow rate (ft<sup>3</sup>/sec)

$e$  = base of natural logarithm = 2.718

Due to variations in particle size distributions and in dust layer resistivity, it is difficult to use the Deutsch-Anderson type equations directly to determine the necessary precipitator size. Furthermore, this approach does not take into account particulate emissions due to rapping re-entrainment, gas sneakage around the fields, and other non-ideal operating conditions.

9 - 65

## Collection Efficiency

### Matts-Ohnfield Equation

$$\eta = 1 - e^{-\left[\omega \left(\frac{A}{Q}\right)\right]^k}$$

Where:  $\eta$  = collection efficiency of the precipitator

$e$  = base of natural logarithm = 2.718

$\omega$  = average migration velocity, cm/s (ft/sec)

$k$  = a constant, usually 0.4 to 0.6

$A$  = collection area, m<sup>2</sup> (ft<sup>2</sup>)

$Q$  = gasflowrate, m<sup>3</sup>/s (ft<sup>3</sup>/sec)

The Matts-Ohnfield equation is a refinement of the Deutsch-Anderson equation

9 - 66

**Table 4-2. Equations used to estimate collection efficiency and collection area**

Calculation	Deutsch-Anderson	Matts-Ohnfeldt
Collection efficiency	$\eta = 1 - e^{-w(A/Q)}$	$\eta = 1 - e^{-w_k(A/Q)^k}$
Collection area (to meet a required efficiency)	$A = \frac{-Q}{w} [\ln(1 - \eta)]$	$A = \left[ \frac{-Q}{w_k} [\ln(1 - \eta)] \right]^{1/k}$
Where:	$\eta$ = collection efficiency A = collection area w = migration velocity Q = gas flow rate ln = natural logarithm	$\eta$ = collection efficiency A = collection area $w_k$ = average migration velocity k = constant (usually 0.5) ln = natural logarithm

**Particle (Theoretical) Migration Velocity**

- The velocity at which a charged particle migrates toward the collecting plate can be calculated by balancing the electrical forces ( $F_E = neE$ ) with the drag force on the particle moving through the gas stream, and then solving for the particle (migration) velocity.

$$\omega = \frac{neEC_c}{3\pi\mu_g d_p}$$

n = number of charges ( $n_{field} + n_{diffusion}$ )  
 e = charge of the electron ( $e = 4.8 \times 10^{-10}$  statcoulumb)  
 E = electric field strength (statvolt/cm)  
 Cc = Cunningham slip correction factor  
 $\mu$  = gas viscosity  
 dp = diameter of particle

**Effective Migration Velocity**

- The calculated figures of *theoretical migration velocity* should not be confused with the “**effective migration velocity**.” The latter is derived from *particulate removal data from a variety of similar units installed previously and are reviewed to determine the effective migration velocity*.
  - The “effective migration velocity” should be more realistically considered as a measure of a precipitation performance rather than a measure of the average theoretical particle migration velocity.
- This empirically derived migration velocity is then used with the Deutsch equation, or its modified variants, and applied to a total ESP to calculate the necessary collection plate area of a new installation.

**Typical effective particle-migration velocity rates for various applications**

Application	Migration velocity	
	(ft/sec)	(cm/s)
Utility fly ash	0.13-0.67	4.0-20.4
Pulverized coal fly ash	0.33-0.44	10.1-13.4
Pulp and paper mills	0.21-0.31	6.4-9.5
Sulfuric acid mist	0.19-0.25	5.8-7.62
Cement (wet process)	0.33-0.37	10.1-11.3
Cement (dry process)	0.19-0.23	6.4-7.0
Gypsum	0.52-0.64	15.8-19.5
Smelter	0.06	1.8
Open-hearth furnace	0.16-0.19	4.9-5.8
Blast furnace	0.20-0.46	6.1-14.0
Hot phosphorous	0.09	2.7
Flash roaster	0.25	7.6
Multiple-hearth roaster	0.26	7.9
Catalyst dust	0.25	7.6
Cupola	0.10-0.12	3.0-3.7

Sources: Theodore and Buonicore 1976; U.S. EPA 1979.

**Example 9-1**

Calculate the expected particulate efficiency for an electrostatic precipitator serving a utility coal-fired boiler. The gas flow rate is 250,000 ACFM. The total collection plate area is 100,000 ft<sup>2</sup>. Use an effective migration velocity of 0.20 ft/sec.

Substituting into the Deutsch-Anderson equation:

$$\eta = 1 - e^{-\frac{0.20}{Q} A} = 1 - e^{-\left[ \left( \frac{0.20 \frac{ft}{sec}}{250,000 \frac{ft^3}{min} \times \frac{min}{60 sec}} \right) \left( \frac{100,000 ft^2}{1} \right) \right]} = 0.99177$$

**Plate Area**

$$A_i = 2(n-1)HL$$

Where:

- $A_i$  = collection plate area in field i (ft<sup>2</sup>)
- n = number of collection plates across unit
- H = height of collection plates (ft)
- L = length of collection plate in direction of gas flow (ft)

### Specific Collecting Area

$$SCA = \frac{A}{Q}$$

Where:

- SCA = specification collection area, ft<sup>2</sup>/10<sup>3</sup> acfm
- A = total collection plate area, ft<sup>2</sup>
- Q = total gas flow rate, ft<sup>3</sup>/min × 0.001

This ratio represents the A/Q relationship in the Deutsch-Anderson equation and consequently is an important determinant of collection efficiency.

Increases in the SCA will increase the collection efficiency of the precipitator

9 - 73

### Efficiency as a Function of SCA at Select Migration Velocities

$$\eta = 1 - e^{-\omega \frac{A}{Q}}$$

SCA × 60/1000 = A/Q above (using conversion factors)

SCA = A/Q can be substituted into above equation. Now only ω and SCA are needed to solve for efficiency.

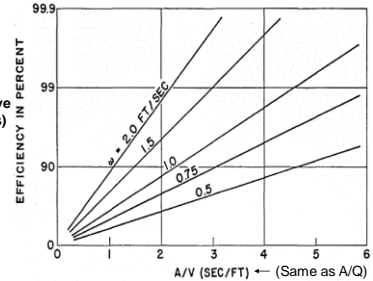

Therefore, when ω is determined experimentally & you have a desired efficiency, you can size the collection plate area (A) at different flow rates (Q).

### Efficiency as a Function of SCA at Select Migration Velocities

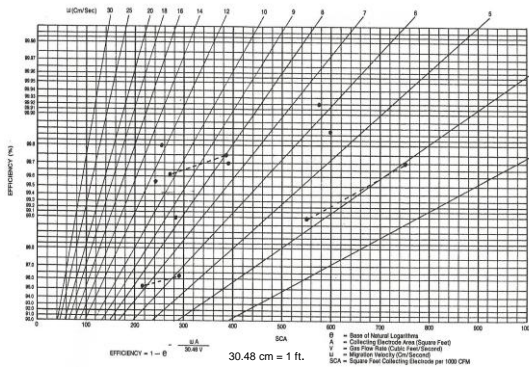

### Aspect Ratio

$$AR = \frac{\sum_{i=1}^n L_i}{H}$$

Where:

- AR = aspect ratio (dimensionless)
- L<sub>i</sub> = length of plates in field i (ft)
- H = collection plate height (ft)
- n = number of fields in series

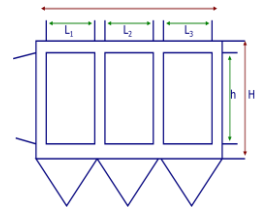

If the aspect ratio is too low, the small particles are swept out of the precipitator before they can reach the hopper. Modern precipitators are designed with aspect ratios of at least 1.0, and the normal range extends to more than 1.5. This means that they are longer than they are high. This provides more time for gravity settling to carry the particulate agglomerates to the hoppers.

9 - 76

### Example 9-3

An electrostatic precipitator serving a cement kiln has four fields in series. All of the fields have collection plates that are 24 feet high. The first two fields have collection plate lengths of 9 feet each. The last two fields have collection plate lengths of 6 feet. What is the aspect ratio?

Solution:

$$AR = \frac{\sum_{i=1}^n L_i}{H} = \frac{9+9+6+6}{24} = 1.25$$

9 - 77

### Summary of Sizing Parameters

Sizing Parameter	Common Range
Specific Collection Area, (ft <sup>2</sup> /1000 ACFM)	400 - 1000
Number of Fields in Series	3 - 14
Aspect Ratio	1 - 1.5
Gas Velocity, ft/sec	3 - 6
Plate-to-plate spacing, inches <sup>1</sup>	9 - 16

<sup>1</sup>One manufacturer uses 6 in. spacing

High gas velocities adversely affect the performance of precipitators, reducing the time available for particle charging and migration, and thereby, add to re-entrainment of emissions.

Plate Spacing: improved electrical field strengths could be obtained by increased discharge electrode-to-collection plate spacing

9 - 78

### Particle Size vs. Efficiency

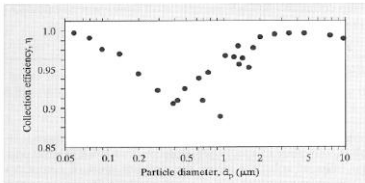

Figure 7.C.4 Measured collection efficiency as a function of particle size for an electrostatic precipitator installed on a pulverized coal boiler. (Reprinted with permission of the Air & Waste Management Association from J.D. McCain et al. [1975].)

Larger particles are removed more efficiently because they acquire a greater electric charge, whereas smaller particles, too, are removed more efficiently because they are subjected to less drag and thus drift more easily, leaving intermediate particles as those that are less efficiently collected. Nonetheless, efficiency easily exceeds 90% for most particles.

### Mass Mean Diameters

Source	MMD <sub>i</sub> (μm)
Bituminous coal	16
Sub-bituminous coal, tangential boiler	21
Sub-bituminous coal, other boiler types	10 to 15
Cement kiln	2 to 5
Glass plant	1
Wood burning boiler	5
Sinter plant,	50
with mechanical precollector	6
Kraft process recovery	2
Incinerators	15 to 30
Copper reverberatory furnace	1
Copper converter	1
Coke plant combustion stack	1
Unknown	1

Determine the MMD (using the particle size distribution method in Chapter 3) of the inlet particle distribution MMD<sub>i</sub> (μm). If this is not known, assume a value from the above table.

### ESP Performance as a Function of MMD In a Computer Model

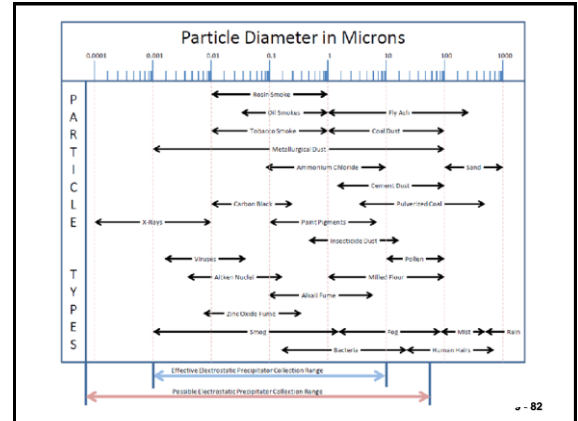
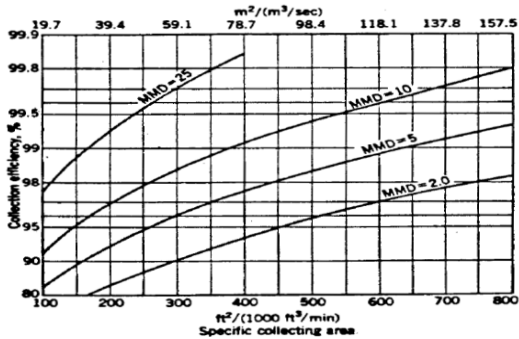

#### Data Used in EPA/RTI Computerized Performance Model for Electrostatic Precipitators

- Manufacturers use mathematical equations and design parameters to estimate collection efficiency or collection area.
- They may also build a pilot-plant to determine the parameters necessary to build the full-scale ESP.
- They may also use a mathematical model or computer program to test the design parameters.

#### ESP Design

- Specific collection area
- Collection plate area
- Collection height and length
- Gas velocity
- Number of fields in series
- Number of discharge electrodes
- Type of discharge electrodes
- Discharge electrode-to-collection plate spacing

#### Particulate Matter and Gas Stream Data

- Resistivity
- Particle size mass median diameter
- Particle size distribution standard deviation
- Gas flow rate distribution standard deviation
- Actual gas flow rate
- Gas stream temperature
- Gas stream pressure
- Gas stream composition

### ESP Performance Evaluation

- Collection efficiency
- Specific collection area
- Sectionalization
- Aspect ratio
- Gas superficial velocity
- Collector plate spacing
- Discharge electrodes
- Rapping systems
- Hopper design
- Flue gas conditioning system
- Instrumentation



### Instrumentation

- **Electrical parameters**
  - Primary voltage, A.C. & Primary current, A.C.
  - Secondary voltage, D.C. Secondary current, D.C.
  - Spark rate
- **Rapper parameters**
  - the specific rappers being activated, the presence of any probable rapper activation faults, and the rapping intensities
- **Inlet and outlet gas temperature & oxygen concentration**
  - often used upstream and downstream of ESPs to detect the onset of air infiltration problems.

9 - 85

### Gauges present on the control cabinet for each precipitator field

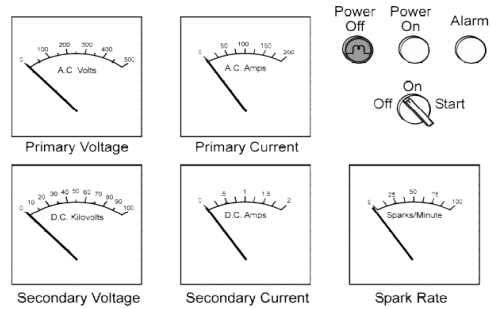

9 - 86

### Typical Permit Conditions

- Opacity limits
- Limits on grain loading
- Ranges of ESP inlet & outlet temperatures
- Minimum total corona power
- Maximum process rate
- Recordkeeping requirements
- CEM requirements
- Maximum pressure drop
- Maximum number fields offline

9 - 87

### Review Recordkeeping

- Design Specifications
- Operating Data & Records
- Inspection & Maintenance Records
- Component Failure Records

9 - 88



**Chapter 10**

**Hoods and Fans**

10 - 1

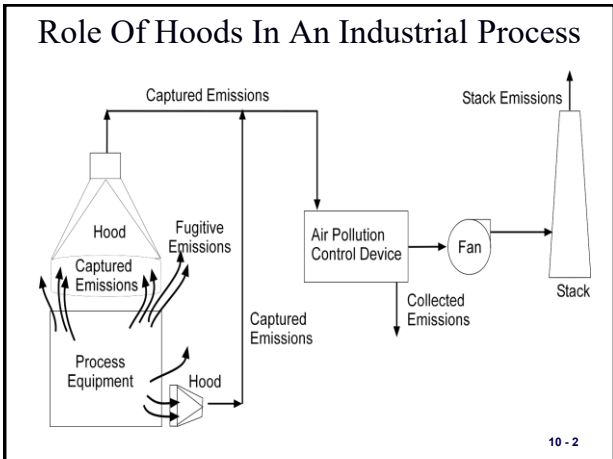

**System Efficiency**

$$Pt_{total} = Pt_{hood} + (1 - Pt_{hood})Pt_{collector}$$

**Efficiency = 1 - Penetration**

10 - 3

- Hoods**
- In processes that are open to the surroundings, pollutants are prevented from escaping by the use of a hood
  - Hoods are an integral part of the process equipment
  - Pollutants not captured by a hood are considered fugitive emissions
    - Because of this, evaluation of the operation of a hood is very important

- Importance of Capture/Collection Systems**
- *From Subpart RRR NESHAP for Secondary Aluminum Production § 63.1506*
  - *Capture/collection systems.* For each affected source or emission unit equipped with an add-on air pollution control device, the owner or operator must:
  - (1) Design and install a system for the capture and collection of emissions to meet the engineering standards for minimum exhaust rates or facial inlet velocities as contained in the ACGIH Guidelines (incorporated by reference see § 63.14);
- 10 - 5



### Importance of Capture/Collection Systems

- Subpart XXX—NESHAP for Ferroalloys Production: Ferromanganese and Silicomanganese § 63.1624 What are the operational and work practice standards for new, reconstructed, and existing facilities?
- (a) *Process fugitive emissions sources.*
- (1) You must prepare, and at all times operate according to, a process fugitive emissions ventilation plan that: documents the equipment and operations designed to effectively capture process fugitive emissions. The plan will be deemed to achieve effective capture if it consists of the following elements: (i) Documentation of engineered hoods and secondary fugitive capture systems designed according to the most recent, at the time of construction, ventilation design principles recommended by the American Conference of Governmental Industrial Hygienists (ACGIH). The process fugitive emissions capture systems must be designed to achieve sufficient air changes to evacuate the collection area frequently enough to ensure process fugitive emissions are effectively collected by the ventilation system and ducted to the control device(s). The required ventilation systems should also use properly positioned hooding to take advantage of the inherent air flows of the source and capture systems that minimize air flows while also intercepting natural air flows or creating air flows to contain the fugitive emissions. Include a schematic for each building indicating duct sizes and locations, hood sizes and locations, control device types, size and locations and exhaust locations. The design plan must identify the key operating parameters and measurement locations to ensure proper operation of the system and establish monitoring parameter values that reflect effective capture.

10 - 7



### Example 10-1

Calculate the fugitive emissions and the stack emissions if the process equipment generates 100 lbm/hr of particulate matter, the hood capture efficiency is 95%, and the collection efficiency of the air pollution control device is 95%.

**Solution:**

Calculate fugitive emissions:

Fugitive emissions = Total emissions – Emissions captured by hood

$$= 100 \frac{\text{lb}_m}{\text{hr}} - 95 \frac{\text{lb}_m}{\text{hr}} = 5 \frac{\text{lb}_m}{\text{hr}}$$

10 - 9

### Example 10-1 (cont.)

Calculate stack emissions:

$$\text{Stack emissions} = \text{Emissions captured by hood} \times \left( \frac{100 - \eta}{100} \right) = \left( 95 \frac{\text{lb}_m}{\text{hr}} \right) \left( \frac{100 - 95}{100} \right) = 4.75 \frac{\text{lb}_m}{\text{hr}}$$

The capture of emissions by the hood is the key step in an air pollution control system. Example 10-1 shows that, even with high hood capture efficiency, fugitive emissions can be higher than emissions leaving the stack.

10 - 10

### Example 10-2

Calculate the stack emissions and fugitive emissions if the process equipment generates 100 lbm/hr of particulate matter, the hood capture efficiency is 90%, and the collection efficiency of the air pollution control device is 95%.

**Solution:**

Calculate fugitive emissions:

Fugitive emissions = Total emissions - Emissions captured by hood

$$= 100 \frac{\text{lb}_m}{\text{hr}} - 90 \frac{\text{lb}_m}{\text{hr}} = 10 \frac{\text{lb}_m}{\text{hr}}$$

Calculate stack emissions:

$$\text{Stack emissions} = \text{Emissions captured by hood} \times \left( \frac{100 - \eta}{100} \right) = \left( 90 \frac{\text{lb}_m}{\text{hr}} \right) \left( \frac{100 - 95}{100} \right) = 4.5 \frac{\text{lb}_m}{\text{hr}}$$

### Types of Hoods

- Enclosure
- Receiving
- Exterior
- Push-pull

10 - 12

Steel Mill Ladle Hood

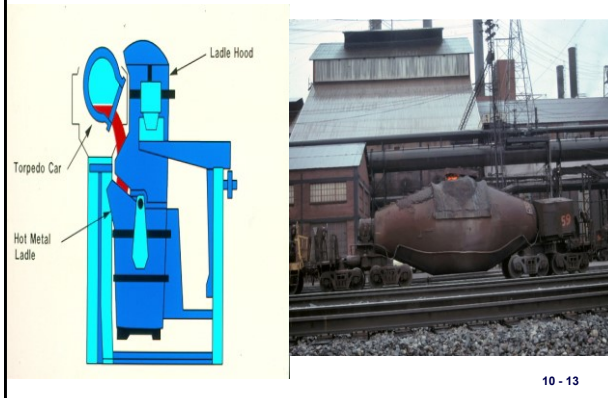

10 - 13

Bagging Area Side Draft Hood

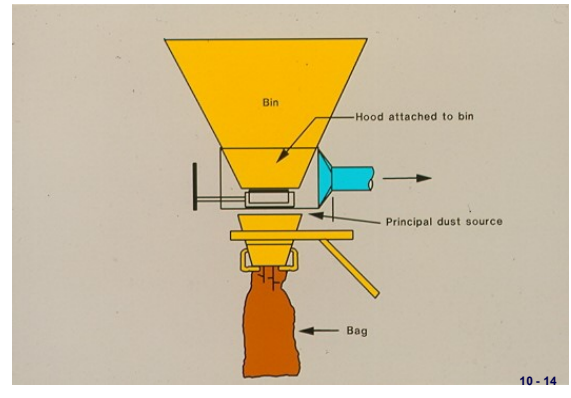

10 - 14

Steel Mill Canopy Hooding

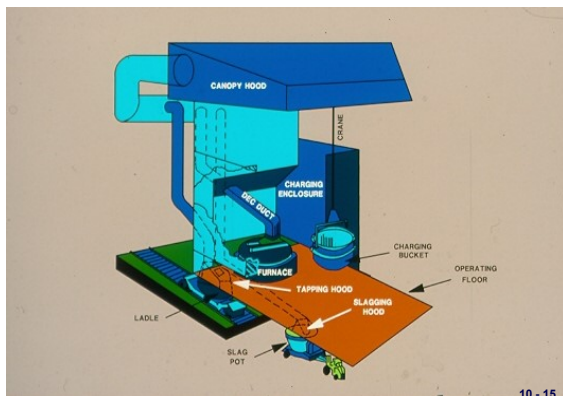

10 - 15



### Hood Design Principles

- Enclose whenever possible
- If can't enclose, place hood close to source
- Locate duct take-offs in the direction of normal contaminate motion

10 - 17

### Hood Operating Principles

- Hoods are generally designed to operate under negative (sub-atmospheric) pressure
- Since air from all directions moves toward the low-pressure hood, the hood must be as close as possible to the process equipment

### Capture Velocity

The velocity at the point of pollutant generation that is necessary to overcome air currents and cause the contaminated air to move into the hood

10 - 19

### Capture Velocities

Type of Material Release	Capture Velocity (ft/min)
With no velocity into quiet air	50-100
At low velocity into moderately still air	100-200
Active generation into zone of rapid air motion	200-500
With high velocity into zone of very rapid air motion	500-2000

10 - 20

### For Cold Flow into Hoods

Capture velocity decreases rapidly with distance from the hood face

10 - 21

Figure 10- 3 Hood Capture Velocities

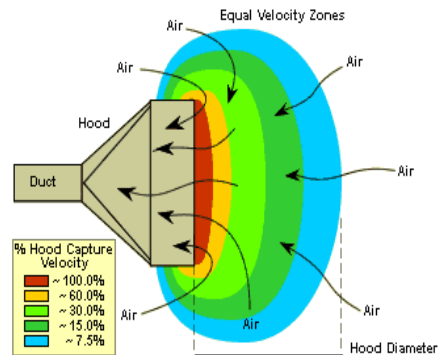

### Flow/Capture Velocity Equation For A Freely Suspended Hood Without A Flange

The equation demonstrates the importance of the proximity of the hood to the source:

$$Q = v_h(10X^2 + A_h)$$

where:

Q = actual volumetric flow rate (ft<sup>3</sup>/min)

X = distance from hood face to farthest point of contaminant release (ft)

v<sub>h</sub> = hood capture velocity at distance X (ft/min)

A<sub>h</sub> = area of hood opening (ft<sup>2</sup>)

10 - 23



**Example 10-3**

The recommended capture velocity for a certain pollutant entering a 16-inch diameter hood is 300 ft/min. What is the required volumetric flow rate for the following distances from the hood face (X)?

A. X = 12 in. (75% of hood diameter)

B. X = 24 in. (150% of hood diameter)

**Solution for Part A:**

$$Q = v_h(10X^2 + A_h)$$

Calculate the area of the hood opening:

$$A_h = \frac{\pi D^2}{4} = \frac{\pi \left[16 \text{ in} \left(\frac{1 \text{ ft}}{12 \text{ in}}\right)\right]^2}{4} = 1.40 \text{ ft}^2$$

10 - 25

**Example 10-3 (cont.)**

Calculate the volumetric flow rate, Q, required to obtain the recommended capture velocity of 300 fpm, at a distance of 12 inches from the hood:

$$Q = v_h(10X^2 + A_h) = 300 \frac{\text{ft}}{\text{min}} [10(1 \text{ ft})^2 + 1.40 \text{ ft}^2] = 3,420 \frac{\text{ft}^3}{\text{min}}$$

**Solution for Part B:**

Calculate the volumetric flow rate, Q, required to obtain the recommended capture velocity of 300 fpm at a distance of 24 inches from the hood:

$$Q = v_h(10X^2 + A_h) = 300 \frac{\text{ft}}{\text{min}} [10(2 \text{ ft})^2 + 1.40 \text{ ft}^2] = 12,420 \frac{\text{ft}^3}{\text{min}}$$

The volumetric flow rate requirements increased approximately four times when the distance between the hood and the contaminant source doubled.

10 - 26

**Effect Of Side Baffles On Hood Capture Velocities**

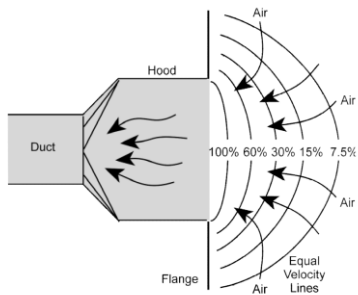

10 - 27

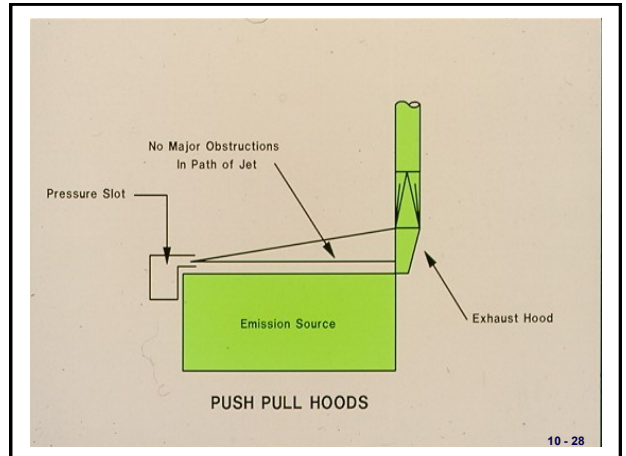

10 - 28



10 - 29

**Hood Designs for Improved Performance**

- Push-pull hood
- A high velocity clean air stream is "pushed" across the area of pollutant generation into a "pull" hood

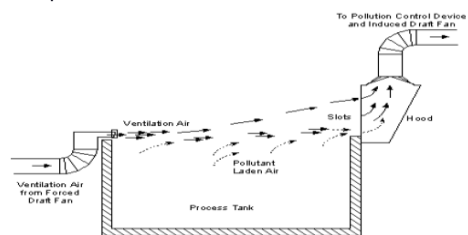

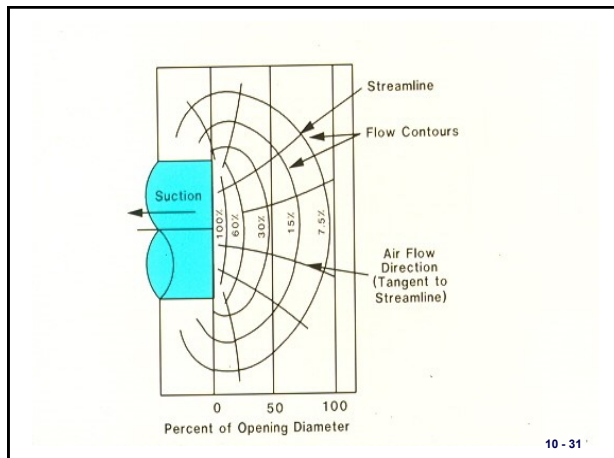

10 - 31

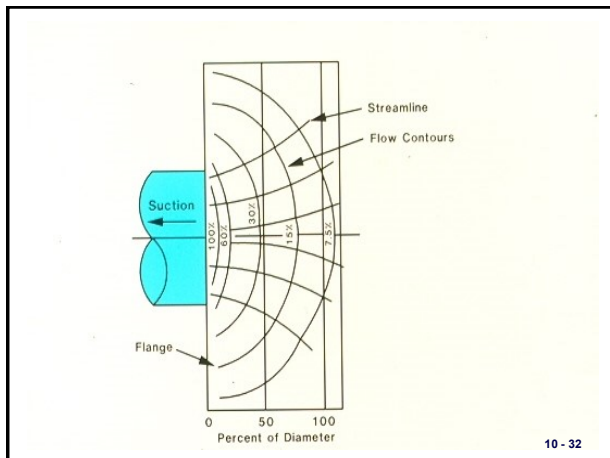

10 - 32

HOOD TYPE	DESCRIPTION	ASPECT RATIO	AIR VOLUME
	SLOT	0.2 or less	$Q = 3.7 LVX$
	FLANGED SLOT	0.2 or less	$Q = 2.8 LVX$
	PLAIN OPENING	0.2 or greater and round	$Q = V(10X - A)$
	FLANGED OPENING	0.2 or greater and round	$Q = 0.75V(10X - A)$
	BOOTH	To suit work	$Q = VA - VWH$
	CANOPY	To suit work	$Q = 1.4 PDV$ <small>P-perimeter of work D-height above work</small>
	PLAIN MULTIPLE SLOT OPENING 2 or more slots	0.2 or greater	$Q = V(10X^2 - A)$
	FLANGED MULTIPLE SLOT OPENING 2 or more slots	0.2 or greater	$Q = 0.75 V(10X^2 - A)$

10 - 33

### For Hot Flow into Hoods

- As the plume rises, it cools and expands and slows down
- Long rise distances make the plume more subject to air currents
- Because of the distance between the source and the hood, air volumes are large

10 - 34

### Monitoring Hood Capture Effectiveness

- Ways to confirm that the hood capture effectiveness has not decreased since it was installed or tested:
- Visible emission observations for fugitive emissions
- Confirm that the hood has not been moved away from the point of pollutant generation and that side baffles and other equipment necessary to maintain good operation have not been damaged or removed.
- The hood static pressure should be monitored to ensure that the appropriate gas flow rate is being maintained. (The *hood static pressure* is simply the static pressure in the duct immediately downstream from the hood).

10 - 35

### Monitoring Hood Capture Effectiveness (Hood Static Pressure)

$$SP_h = VP_d + h_e$$

Where:

- $SP_h$  = hood static pressure
- $VP_d$  = velocity pressure in duct
- $h_e$  = hood entry loss  
=  $F_h VP_d$
- $F_h$  = hood entry loss factor

10 - 36



### Monitoring Hood Capture Effectiveness

The velocity pressure term is due to the energy necessary to accelerate the air from zero velocity to the velocity in the duct. The hood entry loss is usually expressed as some fraction of this velocity pressure:

$$h_e = F_h VP_d$$

where:

$F_h$  = hood entry loss coefficient (dimensionless)

$VP_d$  = duct velocity pressure (in WC)

Hood entry loss coefficients are tabulated in standard texts on hoods and ventilation systems

10 - 37

θ	Entry Loss	
	Round	Rectangular
15°	0.15 VP	0.23 VP
30°	0.08 VP	0.16 VP
45°	0.06 VP	0.15 VP
60°	0.06 VP	0.17 VP
90°	0.15 VP	0.25 VP
120°	0.25 VP	0.35 VP
150°	0.40 VP	0.48 VP

10 - 38

### Vena Contracta

- When air enters a negative pressure duct, the airflow converges as shown on the next slide. The area where air converges upon entering a duct is referred to as *vena contracta*. After the vena contracta, the airflow expands to fill the duct and some of the velocity pressure converts to static pressure. The vena contracta is dependent on the hood geometry, which determines the resistance to airflow entering the hood. In general, the smoother the entry, the lower the entry loss coefficient.

10 - 39

### Vena Contracta

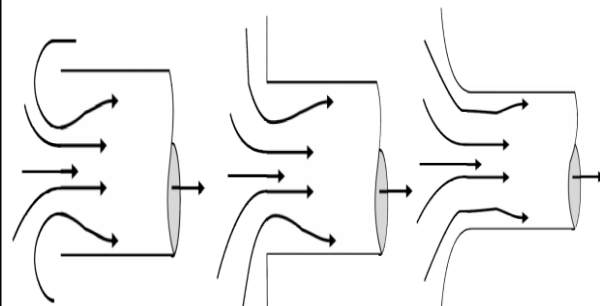

Plain duct end  $h_e = 0.93$  Flanged duct end  $h_e = 0.49$  Bell-mouth inlet  $h_e = 0.04$

10 - 40

### Vena Contracta

The velocity pressure is related to the square of the gas velocity in the duct and the gas density:

$$VP_d = \rho_g \left( \frac{v_d}{1,096.7} \right)^2$$

where:

$VP_d$  = duct velocity pressure (in WC)

$v_d$  = duct gas velocity (ft/min)

$\rho_g$  = gas density (lbm/ft<sup>3</sup>)

As the gas flow rate into the hood increases, the hood static pressure increases. A decrease in hood static pressure (i.e., a less negative value) usually indicates that the gas flow rate entering the hood has decreased from previous levels. This may reduce the effectiveness of the hood by reducing the capture velocities at the hood entrance.

10 - 41

**Example Problems**

**Example 10 - 4**

A hood serving a paint dipping operation has a hood static pressure of 1.10 in WC. The baseline hood static pressure was 1.70 in WC. Estimate the gas flow rate under the following two conditions:

- A. At present operating conditions
- B. At baseline levels

Use the data provided below:

$F_h = 0.93$

Temperature = 68°F

Duct diameter = 2 ft (inside diameter)

10 - 43

**Example 10 - 4**

**Solution for Part A:**

Calculate the velocity pressure in the duct:

$$SP_h = (1 + F_h)VP_d$$

$$VP_d = \frac{SP_h}{1 + F_h} = \frac{1.10 \text{ in WC}}{1 + 0.93} = 0.57 \text{ in WC}$$

Calculate the gas velocity in the duct:

$$VP_d = \rho_g \left( \frac{v_d}{1,096.7} \right)^2$$

10 - 44

**Example 10 - 4**

$$v_d = 1,096.7 \sqrt{\frac{VP_d}{\rho_g}} = 1,096.7 \sqrt{\frac{0.57 \text{ in WC}}{0.0747 \frac{\text{lb}_m}{\text{ft}^3}}} = 3,029.5 \frac{\text{ft}}{\text{min}}$$

Calculate the gas flow rate:

$$Q = v_d A_d = v_d \left( \frac{\pi D^2}{4} \right) = 3,029.5 \frac{\text{ft}}{\text{min}} \left[ \frac{\pi (2 \text{ ft})^2}{4} \right] = 9,517.5 \frac{\text{ft}^3}{\text{min}}$$

10 - 45

**Example 10 - 4**

**Solution for Part B:**

Calculate the velocity pressure in the duct:

$$SP_h = (1 + F_h)VP_d$$

$$VP_d = \frac{SP_h}{1 + F_h} = \frac{1.70 \text{ in WC}}{1 + 0.93} = 0.88 \text{ in WC}$$

Calculate the gas velocity in the duct:

$$VP_d = \rho_g \left( \frac{v_d}{1,096.7} \right)^2$$

$$v_d = 1,096.7 \sqrt{\frac{VP_d}{\rho_g}} = 1,096.7 \sqrt{\frac{0.88 \text{ in WC}}{0.0747 \frac{\text{lb}_m}{\text{ft}^3}}} = 3,764.2 \frac{\text{ft}}{\text{min}}$$

10 - 46

**Example 10 - 4**

Calculate the gas velocity in the duct:

$$VP_d = \rho_g \left( \frac{v_d}{1,096.7} \right)^2$$

$$v_d = 1,096.7 \sqrt{\frac{VP_d}{\rho_g}} = 1,096.7 \sqrt{\frac{0.88 \text{ in WC}}{0.0747 \frac{\text{lb}_m}{\text{ft}^3}}} = 3,764.2 \frac{\text{ft}}{\text{min}}$$

Calculate the gas flow rate:

$$Q = v_d A_d = v_d \left( \frac{\pi D^2}{4} \right) = 3,764.2 \frac{\text{ft}}{\text{min}} \left[ \frac{\pi (2 \text{ ft})^2}{4} \right] = 11,819.9 \frac{\text{ft}^3}{\text{min}}$$

The change in hood static pressure from 1.7 in WC to 1.1 in WC indicates a drop in the gas flow rate from 11,820 acfm to 9,518 acfm. This is nearly a 20% decrease in the gas flow rate.

10 - 47

**Transport Velocity**

**The duct velocity necessary to prevent dust buildup**

10 - 48

### RANGE OF DESIGN VELOCITIES

Contaminant	Design Velocity (ft/min)
Vapors, gases, smoke	Any (usually 1000-2000)
Fumes	1400-2000
Very fine, light dust	2000-2500
Dry dust and powders	2500-3500
Average industrial dust	3500-4000
Heavy dusts	4000-4500
Heavy or moist	4500 and up

10 - 49

### Example 10 - 5

A duct system transporting a dry dust requires a minimum transport velocity of 2,800 ft/min. The volumetric flow rate for the system is 978 acfm. What is the necessary duct diameter in inches for this section of ductwork to maintain the minimum transport velocity?

**Solution:**

Calculate the duct area:

$$A_d = \frac{Q}{v_d} = \frac{978 \frac{\text{ft}^3}{\text{min}}}{2,800 \frac{\text{ft}}{\text{min}}} = 0.349 \text{ft}^2$$

Calculate the duct diameter:

$$A_d = \frac{\pi D^2}{4}$$

$$D = \sqrt{\frac{4A_d}{\pi}} = \sqrt{\frac{4(0.349 \text{ft}^2)}{\pi}} = 0.667 \text{ft} = 8 \text{in}$$

10 - 50

## Fans

10 - 51

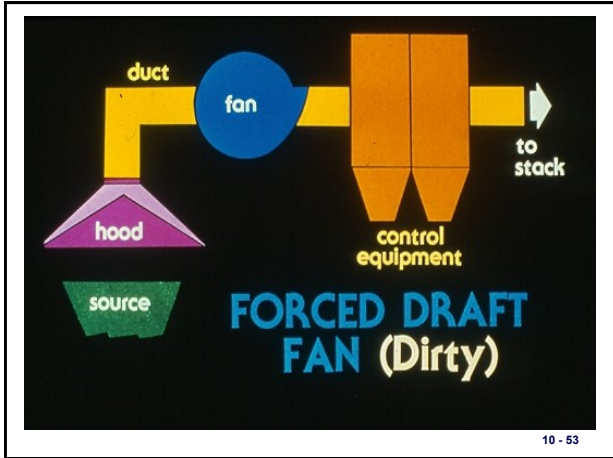
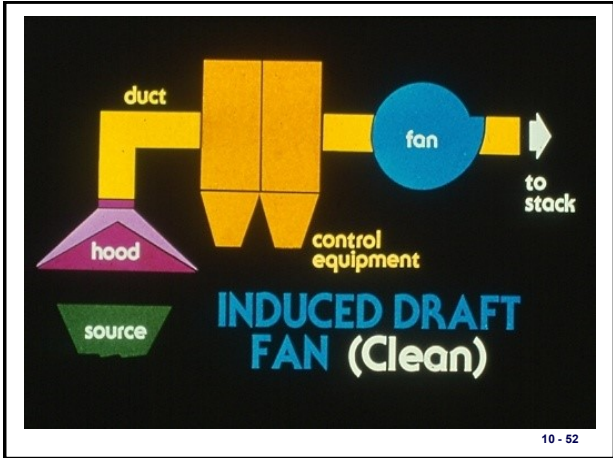

- ### Types of Fans
- Axial
  - Centrifugal
  - Special
- 10 - 54

### Axial Fans

- Propeller
- Tube axial
- Vane axial

10 - 55

### Fan Drives

The major components of a typical centrifugal fan include the fan wheel, fan housing, drive mechanism, and inlet dampers and/or outlet dampers. A wide variety of fan designs serve different applications.

The fan drive determines the speed of the fan wheel and the extent to which this speed can be varied. The types of fan drives can be grouped into three basic categories:

- Direct drive
- Belt drive
- Variable drive

In a *direct drive* arrangement, the fan wheel is linked directly to the shaft of the motor. This means that the fan wheel speed is identical to the motor rotational speed. With this type of fan drive, the fan speed cannot be varied.

10 - 56

### Fan Drives

- *Belt driven fans* use multiple belts which rotate over a set of sheaves or pulleys mounted on the motor shaft and the fan wheel shaft. This type of drive mechanism is illustrated in the figure below.

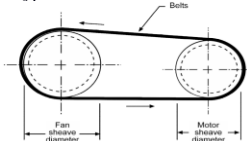

The belts transmit the mechanical energy from the motor to the fan. The fan wheel speed is simply the ratio of the fan wheel sheave diameter to the motor sheave diameter.

$$RPM_{fan} = RPM_{motor} \frac{D_{motor}}{D_{fan}}$$

where

- RPM<sub>fan</sub> = fan speed (revolutions per minute)
- RPM<sub>motor</sub> = motor speed (revolutions per minute)
- D<sub>fan</sub> = diameter of fan sheave (inches)
- D<sub>motor</sub> = diameter of motor sheave (inches)

10 - 57

### VANEAXIAL

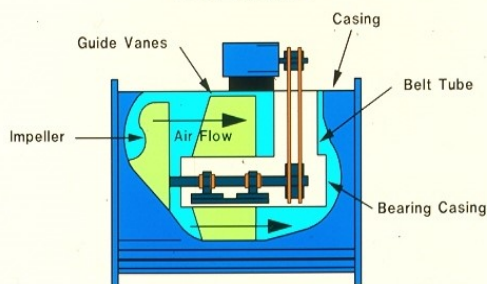

10 - 58

### Centrifugal Fans

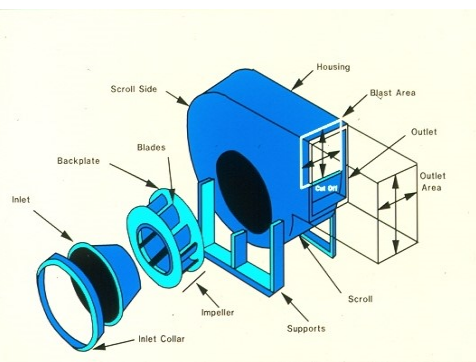

10 - 59

### Centrifugal Fan Wheels

- Forward inclined
- Radial
- Backward inclined
  - Standard blade
  - Airfoil blade

10 - 60

Source Simulator For APTI 450/468 Course



10 - 61



**FORWARD CURVED**

- Has 24-64 shallow blades
- Efficiency less than backward inclined
- Smallest of all centrifugal fans
- Operates at lowest speed

10 - 62



**RADIAL**

- Has 6-10 blades
- Least efficient
- Narrowest of all centrifugal fans
- Operates at medium speed

10 - 63



**BACKWARD INCLINED -- STANDARD BLADE**

- Has 9-16 blades
- Efficiency only slightly less than airfoil
- Operates at high speed

10 - 64



**BACKWARD INCLINED -- AIRFOIL BLADE**

- Has 9-16 blades
- Most efficiency
- Operates at highest speed

10 - 65

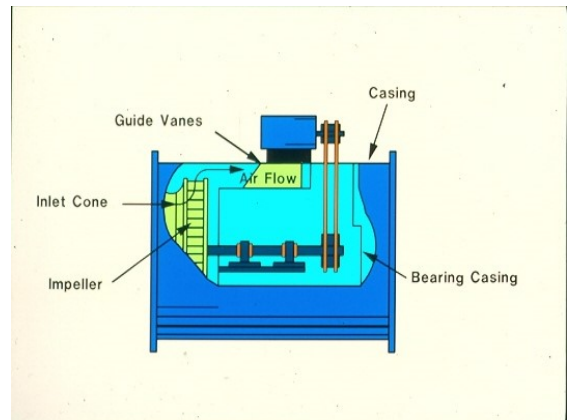

10 - 66

Centrifugal Fan Operating Principles

The flow rate of gas moving through the fan depends on the fan wheel rotational speed. As the speed increases, the gas flow rate increases proportionally. This relationship is expressed as one of the fan laws:

$$Q_2 = Q_1 \left( \frac{RPM_2}{RPM_1} \right)$$

where  
 Q<sub>1</sub> = baseline gas flow rate (acfm)  
 Q<sub>2</sub> = present gas flow rate (acfm)  
 RPM<sub>1</sub> = baseline fan wheel rotational speed (revolutions per minute)  
 RPM<sub>2</sub> = present fan wheel rotational speed (revolutions per minute)

Centrifugal Fan Operating Principles

$$\text{Fan SP} = \text{SP}_{\text{out}} - \text{SP}_{\text{in}} - \text{VP}_{\text{in}}$$

For the conditions shown in the figure, Fan SP = 0.05 - (-10) - 0.50 = 9.55 in WC.

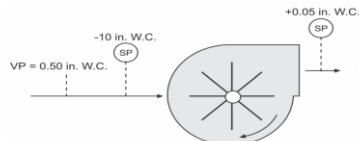

Figure 10-13. Fan static pressure rise

Fan SP is related to the square of the fan speed, as indicated in the second fan law:

$$\text{Fan SP}_2 = \text{Fan SP}_1 \left( \frac{RPM_2}{RPM_1} \right)^2$$

where  
 Fan SP<sub>1</sub> = baseline fan static pressure (in WC)  
 Fan SP<sub>2</sub> = present fan static pressure (in WC)  
 RPM<sub>1</sub> = baseline fan wheel rotational speed (revolutions per minute)  
 RPM<sub>2</sub> = present fan wheel rotational speed (revolutions per minute)

Fan Laws

Fan Law 1

$$CFM_2 = CFM_1 \times \left( \frac{RPM_2}{RPM_1} \right)$$

Fan Law 2

$$SP_2 = SP_1 \times \left( \frac{RPM_2}{RPM_1} \right)^2$$

Fan Law 3

$$HP_2 = HP_1 \times \left( \frac{RPM_2}{RPM_1} \right)^3$$

FAN LAWS

$$Q_2 = Q_1 \left( \frac{\text{size}_2}{\text{size}_1} \right)^3 \left( \frac{rpm_2}{rpm_1} \right)$$

$$P_2 = P_1 \left( \frac{\text{size}_2}{\text{size}_1} \right)^2 \left( \frac{rpm_2}{rpm_1} \right)^2 \left( \frac{\rho_2}{\rho_1} \right)$$

$$bhp_2 = bhp_1 \left( \frac{\text{size}_2}{\text{size}_1} \right)^5 \left( \frac{rpm_2}{rpm_1} \right)^3 \left( \frac{\rho_2}{\rho_1} \right)$$

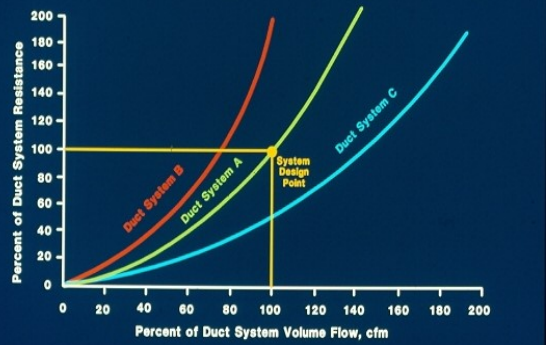

Portion of a typical multi-rating table

194 LS		Inlet diameter: 11" O.D. Wheel diameter: 19 1/4"										Outlet area: .660 sq. ft. inside Wheel circumference: 5.01 ft							
CFM	OV	2"SP		4"SP		6"SP		8"SP		10"SP		12"SP		14"SP		16"SP		18"SP	
		RPM	BHP	RPM	BHP	RPM	BHP	RPM	BHP	RPM	BHP	RPM	BHP	RPM	BHP	RPM	BHP	RPM	BHP
660	1000	699	0.48	1392	1.01	1698	1.60	1960	2.27	2191	2.99	2399	3.74	2592	4.55	2769	5.38	2938	6.27
792	1200	1008	0.55	1998	1.11	2703	1.75	3167	2.45	3712	3.20	4298	3.99	4968	4.83	5767	5.71	6708	6.65
924	1400	1223	0.62	2406	1.23	3708	1.90	4365	2.64	5104	3.43	5911	4.22	6807	5.14	7908	6.05	9252	7.01
1056	1600	1442	0.71	2814	1.35	4716	2.07	5571	2.84	6517	3.67	7601	4.53	8899	5.46	10497	6.42	12456	7.41
1188	1800	1661	0.80	3421	1.45	5724	2.24	6580	3.06	7703	3.92	9007	4.83	10593	5.78	12471	6.79	14658	7.9
1320	2000	1884	0.90	4028	1.54	6732	2.44	7887	3.25	9209	4.19	10714	5.15	12600	6.13	14772	7.16	17340	8.4
1452	2200	2109	1.01	4635	1.63	7740	2.63	9094	3.54	10511	4.46	12222	5.43	14107	6.36	16578	7.55	19440	8.9
1584	2400	2335	1.13	5242	1.73	8748	2.87	10112	3.80	11729	4.79	13831	5.82	16212	6.87	19098	7.98	22800	9.5
1716	2600	2562	1.24	5850	1.83	9756	3.10	11215	4.08	12942	5.11	15141	6.18	17823	7.29	21201	8.40	25560	10.2
1848	2800	2790	1.35	6458	1.93	10764	3.32	12318	4.30	14259	5.43	16451	6.46	19234	7.61	22512	8.81	27072	10.9
1980	3000	3018	1.46	7066	2.03	11772	3.54	13326	4.52	15376	5.74	17763	6.79	20545	8.14	24024	9.31	28584	11.6
2112	3200	3246	1.57	7674	2.13	12780	3.76	14334	4.74	16383	5.96	18870	7.02	21957	8.27	25536	9.62	30096	12.3
2244	3400	3474	1.68	8282	2.23	13788	3.98	15342	4.96	17390	6.18	20076	7.30	23369	8.39	27048	9.93	31608	13.0
2376	3600	3702	1.79	8890	2.33	14796	4.20	16350	5.18	18397	6.40	21084	7.52	24781	8.51	28560	10.24	33120	13.7
2508	3800	3930	1.90	9498	2.43	15804	4.42	17358	5.40	19404	6.62	22092	7.74	26193	8.63	29572	10.55	34632	14.4
2640	4000	4158	2.01	10106	2.53	16812	4.64	18366	5.62	20412	6.84	23100	7.96	27205	8.75	30584	10.86	36144	15.1
2772	4200	4386	2.12	10714	2.63	17820	4.86	19374	5.84	21420	7.06	24108	8.17	28217	8.87	31596	11.17	37656	15.8
2904	4400	4614	2.23	11322	2.73	18828	5.08	20382	6.06	22428	7.28	25116	8.39	29229	9.00	32608	11.48	39168	16.5
3036	4600	4842	2.34	11930	2.83	19836	5.30	21390	6.28	23436	7.50	26124	8.61	30241	9.11	33620	11.79	40680	17.2
3168	4800	5070	2.45	12538	2.93	20844	5.52	22398	6.50	24444	7.72	27132	8.83	31253	9.23	34632	12.10	42192	17.9
3300	5000	5298	2.56	13146	3.03	21852	5.74	23406	6.72	25452	7.94	28140	9.05	32265	9.35	35644	12.41	43704	17.6
3432	5200	5526	2.67	13754	3.13	22860	5.96	24414	6.94	26460	8.16	29148	9.27	33277	9.47	36656	12.72	45216	18.3
3564	5400	5754	2.78	14362	3.23	23868	6.18	25422	7.16	27468	8.38	30156	9.49	34289	9.59	37668	13.03	46728	19.0
3696	5600	5982	2.89	14970	3.33	24876	6.40	26430	7.38	28476	8.60	31164	9.71	35301	9.71	38680	13.34	48240	19.7

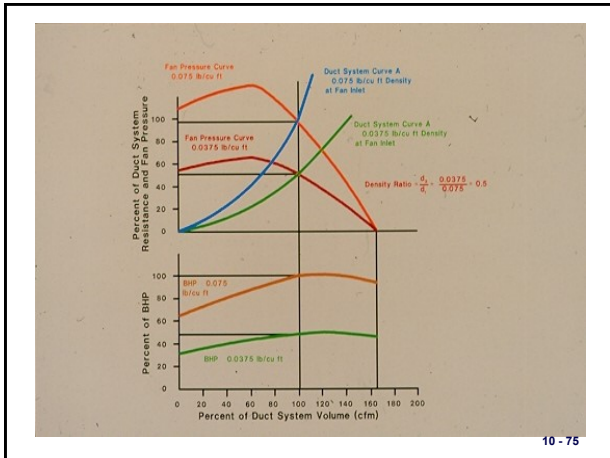
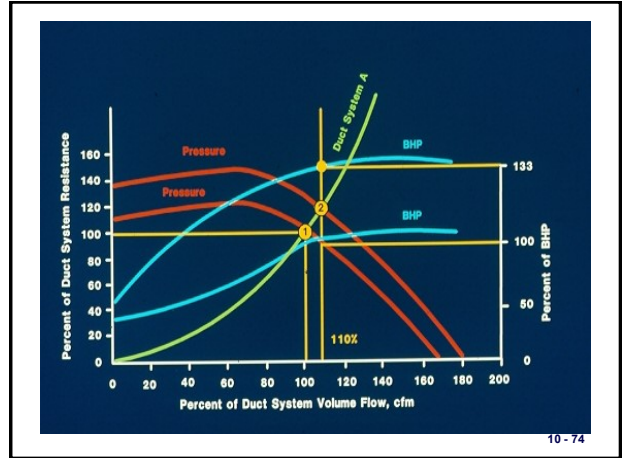
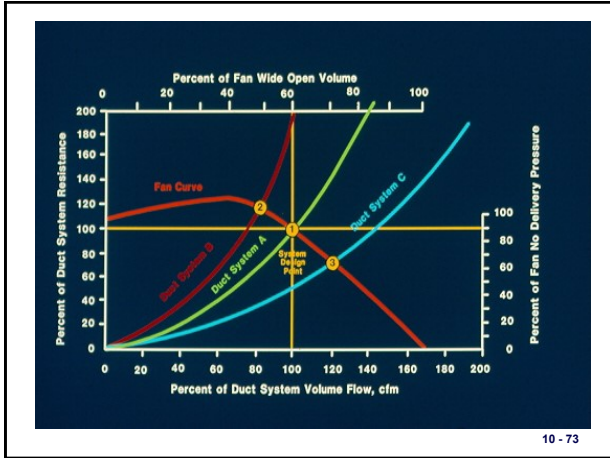

### Example 10 - 6

The static pressure drop across a ventilation system, measured at the fan inlet, is -16.5 in WC at a gas flow rate of 8,000 acfm. Estimate the static pressure drop if the flow rate is increased to 12,000 acfm.

**Solution:**

$$\frac{\Delta SP_{high\ flow}}{\Delta SP_{low\ flow}} = \left( \frac{Q_{high\ flow}}{Q_{low\ flow}} \right)^2$$

$$\Delta SP_{high\ flow} = \Delta SP_{low\ flow} \left( \frac{Q_{high\ flow}}{Q_{low\ flow}} \right)^2 = -16.5\text{ in WC} \left( \frac{12,000\text{ acfm}}{8,000\text{ acfm}} \right)^2 = -37.1\text{ in WC}$$

### Brake Horsepower BHP, Fan Speed and Fan Motor Current Relationships

$$BHP = \frac{1.73 I \cdot E \cdot \text{Eff} \cdot \text{PF}}{745}$$

where

- BHP = brake horsepower
- I = fan motor current (amperes)
- E = voltage (volts)
- Eff = efficiency expressed as a decimal
- PF = power factor

$$BHP_2 = BHP_1 \left( \frac{RPM_2}{RPM_1} \right)^3$$

where:

- BHP<sub>1</sub> = baseline brake horsepower
- BHP<sub>2</sub> = present brake horsepower
- RPM<sub>1</sub> = baseline fan wheel rotational speed (revolutions per minute)
- RPM<sub>2</sub> = present fan wheel rotational speed (revolutions per minute)

### Brake Horsepower BHP, Fan Speed and Fan Motor Current Relationships

$$I_{STP} = I_{actual} \left( \frac{\rho_{STP}}{\rho_{actual}} \right)$$

where

- $I_{STP}$  = fan motor current at standard conditions (amperes)
- $I_{actual}$  = fan motor current at actual conditions (amperes)
- $\rho_{STP}$  = gas density at standard conditions ( $lb_m/ft^3$ )
- $\rho_{actual}$  = gas density at actual conditions ( $lb_m/ft^3$ )

10 - 79

### Example 10 - 7

A fan motor is operating at 80 amps and the gas flow rate through the system is 10,000 acfm at 300°F and -10 in WC (fan inlet). What is the motor current at standard conditions?

Solution:

$$I_{STP} = I_{actual} \left( \frac{\rho_{STP}}{\rho_{actual}} \right)$$

Calculate the gas density at actual conditions:

$$\rho = \frac{P \cdot MW}{RT}$$

$$P = (407 \text{ in WC} - 10 \text{ in WC}) \left( \frac{1 \text{ atm}}{407 \text{ in WC}} \right) = 0.975 \text{ atm}$$

$$T = 300^\circ\text{F} + 460 = 760^\circ\text{R}$$

10 - 80

### Example 10 - 7

$$\rho = \frac{P \cdot MW}{RT} = \frac{(0.975 \text{ atm}) \left( 29 \frac{lb_m}{lb\text{-mole}} \right)}{\left( 0.73 \frac{\text{atm} \cdot ft^3}{lb\text{-mole} \cdot ^\circ R} \right) (760^\circ R)} = 0.0510 \frac{lb_m}{ft^3}$$

Calculate the motor current at standard conditions:

$$I_{STP} = I_{actual} \left( \frac{\rho_{STP}}{\rho_{actual}} \right) = 80 \text{ amps} \left( \frac{0.0747 \frac{lb_m}{ft^3}}{0.0510 \frac{lb_m}{ft^3}} \right) = 117 \text{ amps}$$

10 - 81

### Example 10 - 7

- Note 1: The problem could have been solved quickly by using tabulated values of the gas density. However, this approach also reduces the risk of a gas density error caused by not taking into account the effect of pressure changes.
- Note 2: The gas composition could be taken into account by calculating the weighted average molecular weights of the constituents rather than assuming 29 pounds per pound mole, which is close to the value for air. This correction is important when the gas stream has a high concentration of compounds such as carbon dioxide or water, which have molecular weights that are much different than air.

10 - 82

### Summary

- Centrifugal fans are the most commonly used type of fan in air pollution control systems because of their ability to generate high pressure rises in the gas stream.
- The major components of a typical centrifugal fan include the fan wheel, fan housing, drive mechanism, and inlet dampers and/or outlet dampers.
- The intersection of the fan characteristic curve and the system characteristic curve is called the operating point for the fan.
- The factors that affect the fan characteristic curve are the type of fan wheel and blade, the fan wheel rotational speed, and the shape of the fan housing.

10 - 83

### Summary

- System characteristic curves are helpful indicators in determining if a change in the system has occurred.
- A change in the system can also be detected through the fan motor current data that corresponds with the gas flow rate, provided the system resistance has not changed.
- The fan laws can predict how a fan will be affected by a change in an operating condition.

10 - 84



## Summary

- The fan laws apply to fans having the same geometric shape and operating at the same point on the fan characteristic curve.
- A fan will move a constant volume of air, however the amount of work required to move the gas flow is dependent on the density of the gas.

10 - 85

United States Environmental Protection Agency      Office of Air Quality Planning and Standards Research Triangle Park, NC      EPA 340/1-92-018a September 1992 Revised March 1993  
*Stationary Source Compliance Training Series*

 **EPA COURSE #345**

**EMISSION CAPTURE AND  
GAS HANDLING SYSTEM  
INSPECTION**

**Instructor Reference Material**

*Fans and Fan Systems*



<http://www2.epa.gov/nscep>

10 - 86